



wwPDB X-ray Structure Validation Summary Report ⓘ

Mar 9, 2026 – 06:54 PM UTC

PDB ID : 7FF9 / pdb_00007ff9
Title : Pseudomonas aeruginosa Virulence Factor Regulator with cAMP ligand and Cl(triethylphosphine)gold(I)
Authors : Chew, B.L.A.; Luo, D.
Deposited on : 2021-07-23
Resolution : 2.40 Å(reported)

This is a wwPDB X-ray Structure Validation Summary Report for a publicly released PDB entry.

We welcome your comments at validation@mail.wwpdb.org

A user guide is available at

<https://www.wwpdb.org/validation/2017/XrayValidationReportHelp>

with specific help available everywhere you see the ⓘ symbol.

The types of validation reports are described at

<http://www.wwpdb.org/validation/2017/FAQs#types>.

The following versions of software and data (see [references ⓘ](#)) were used in the production of this report:

MolProbity : 4-5-2 with Phenix2.0
Mogul : 2022.3.0, CSD as543be (2022)
Xtriage (Phenix) : 2.0
EDS : 3.0
Buster-report : wwPDB partial adaption of 1.1.7 (2018)
Percentile statistics : 20250101.v01 (using entries in the PDB archive January 1st 2025)
CCP4 : 9.0.010 (Gargrove)
Density-Fitness : 1.0.12
Ideal geometry (proteins) : Engh & Huber (2001)
Ideal geometry (DNA, RNA) : Parkinson et al. (1996)
Validation Pipeline (wwPDB-VP) : 2.49

1 Overall quality at a glance

The following experimental techniques were used to determine the structure:

X-RAY DIFFRACTION

The reported resolution of this entry is 2.40 Å.

Percentile scores (ranging between 0-100) for global validation metrics of the entry are shown in the following graphic. The table shows the number of entries on which the scores are based.

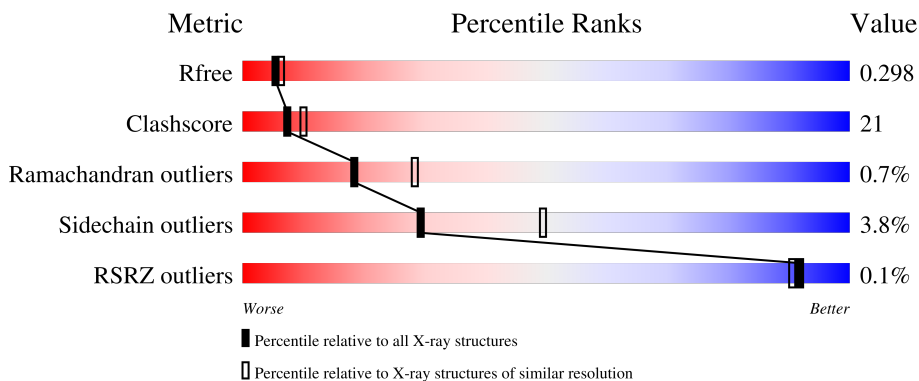



Metric	Whole archive (#Entries)	Similar resolution (#Entries, resolution range(Å))
R_{free}	180053	4912 (2.40-2.40)
Clashscore	190562	5391 (2.40-2.40)
Ramachandran outliers	187476	5320 (2.40-2.40)
Sidechain outliers	187428	5321 (2.40-2.40)
RSRZ outliers	180081	4916 (2.40-2.40)

The table below summarises the geometric issues observed across the polymeric chains and their fit to the electron density. The red, orange, yellow and green segments of the lower bar indicate the fraction of residues that contain outliers for ≥ 3 , 2, 1 and 0 types of geometric quality criteria respectively. A grey segment represents the fraction of residues that are not modelled. The numeric value for each fraction is indicated below the corresponding segment, with a dot representing fractions $\leq 5\%$. The upper red bar (where present) indicates the fraction of residues that have poor fit to the electron density. The numeric value is given above the bar.

Mol	Chain	Length	Quality of chain
1	A	210	 68% 25% • 6%
1	B	210	 61% 27% • 7%
1	C	210	 59% 31% • • 6%
1	D	210	 69% 24% • 6%
1	E	210	 65% 23% • 8%

Continued on next page...

Continued from previous page...

Mol	Chain	Length	Quality of chain
1	F	210	
1	G	210	
1	H	210	

The following table lists non-polymeric compounds, carbohydrate monomers and non-standard residues in protein, DNA, RNA chains that are outliers for geometric or electron-density-fit criteria:

Mol	Type	Chain	Res	Chirality	Geometry	Clashes	Electron density
4	CL	A	307	-	-	X	-
4	CL	B	308	-	-	X	-
4	CL	B	309	-	-	X	-
4	CL	C	308	-	-	X	-
4	CL	D	307	-	-	X	-
4	CL	E	307	-	-	X	-
4	CL	G	307	-	-	X	-
4	CL	H	305	-	-	X	-
5	SO4	C	302	-	-	X	-
5	SO4	E	302	-	-	X	-

2 Entry composition [i](#)

There are 6 unique types of molecules in this entry. The entry contains 23885 atoms, of which 11355 are hydrogens and 0 are deuteriums.

In the tables below, the ZeroOcc column contains the number of atoms modelled with zero occupancy, the AltConf column contains the number of residues with at least one atom in alternate conformation and the Trace column contains the number of residues modelled with at most 2 atoms.

- Molecule 1 is a protein called cAMP-activated global transcriptional regulator Vfr.

Mol	Chain	Residues	Atoms						ZeroOcc	AltConf	Trace
			Total	C	H	N	O	S			
1	A	197	2877	923	1413	256	274	11	0	0	0
1	B	195	2877	924	1412	250	281	10	0	0	0
1	C	197	2935	933	1452	260	279	11	0	0	0
1	D	198	2873	926	1406	249	282	10	0	0	0
1	E	194	2828	908	1389	251	269	11	0	0	0
1	F	188	2744	882	1347	240	267	8	0	0	0
1	G	197	3003	945	1495	269	283	11	0	0	0
1	H	186	2748	882	1353	235	269	9	0	0	0

- Molecule 2 is ADENOSINE-3',5'-CYCLIC-MONOPHOSPHATE (CCD ID: CMP) (formula: C₁₀H₁₂N₅O₆P) (labeled as "Ligand of Interest" by depositor).

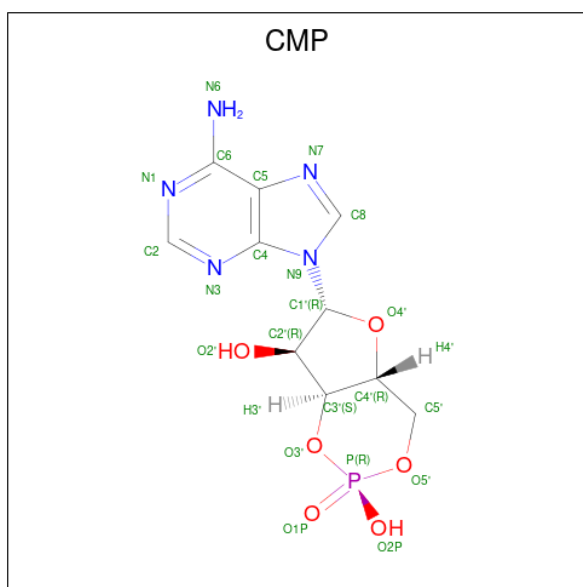

Mol	Chain	Residues	Atoms					ZeroOcc	AltConf	
			Total	C	H	N	O			P
2	A	1	Total 33	C 10	H 11	N 5	O 6	P 1	0	0
2	B	1	Total 33	C 10	H 11	N 5	O 6	P 1	0	0
2	C	1	Total 33	C 10	H 11	N 5	O 6	P 1	0	0
2	D	1	Total 33	C 10	H 11	N 5	O 6	P 1	0	0
2	E	1	Total 33	C 10	H 11	N 5	O 6	P 1	0	0
2	F	1	Total 33	C 10	H 11	N 5	O 6	P 1	0	0
2	G	1	Total 33	C 10	H 11	N 5	O 6	P 1	0	0
2	H	1	Total 33	C 10	H 11	N 5	O 6	P 1	0	0

- Molecule 3 is GOLD ION (CCD ID: AU) (formula: Au) (labeled as "Ligand of Interest" by depositor).

Mol	Chain	Residues	Atoms	ZeroOcc	AltConf
3	A	4	Total 4 Au 4	0	0
3	B	5	Total 5 Au 5	0	0
3	C	5	Total 5 Au 5	0	0

Continued on next page...

Continued from previous page...

Mol	Chain	Residues	Atoms	ZeroOcc	AltConf
3	D	4	Total Au 4 4	0	0
3	E	4	Total Au 4 4	0	0
3	F	3	Total Au 3 3	0	0
3	G	3	Total Au 3 3	0	0
3	H	3	Total Au 3 3	0	0

- Molecule 4 is CHLORIDE ION (CCD ID: CL) (formula: Cl) (labeled as "Ligand of Interest" by depositor).

Mol	Chain	Residues	Atoms	ZeroOcc	AltConf
4	A	2	Total Cl 2 2	0	0
4	B	3	Total Cl 3 3	0	0
4	C	2	Total Cl 2 2	0	0
4	D	2	Total Cl 2 2	0	0
4	E	1	Total Cl 1 1	0	0
4	F	1	Total Cl 1 1	0	0
4	G	2	Total Cl 2 2	0	0
4	H	1	Total Cl 1 1	0	0

- Molecule 5 is SULFATE ION (CCD ID: SO4) (formula: O₄S).



Mol	Chain	Residues	Atoms	ZeroOcc	AltConf
5	C	1	Total O S 5 4 1	0	0
5	E	1	Total O S 5 4 1	0	0
5	G	1	Total O S 5 4 1	0	0

- Molecule 6 is water.

Mol	Chain	Residues	Atoms	ZeroOcc	AltConf
6	A	80	Total O 80 80	0	0
6	B	69	Total O 69 69	0	0
6	C	104	Total O 104 104	0	0
6	D	91	Total O 91 91	0	0
6	E	73	Total O 73 73	0	0
6	F	58	Total O 58 58	0	0
6	G	112	Total O 112 112	0	0
6	H	89	Total O 89 89	0	0

3 Residue-property plots

These plots are drawn for all protein, RNA, DNA and oligosaccharide chains in the entry. The first graphic for a chain summarises the proportions of the various outlier classes displayed in the second graphic. The second graphic shows the sequence view annotated by issues in geometry and electron density. Residues are color-coded according to the number of geometric quality criteria for which they contain at least one outlier: green = 0, yellow = 1, orange = 2 and red = 3 or more. A red dot above a residue indicates a poor fit to the electron density ($RSRZ > 2$). Stretches of 2 or more consecutive residues without any outlier are shown as a green connector. Residues present in the sample, but not in the model, are shown in grey.

- Molecule 1: cAMP-activated global transcriptional regulator Vfr

Chain A: 

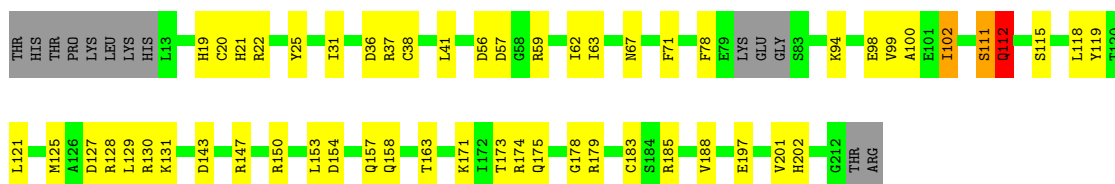

- Molecule 1: cAMP-activated global transcriptional regulator Vfr

Chain B: 

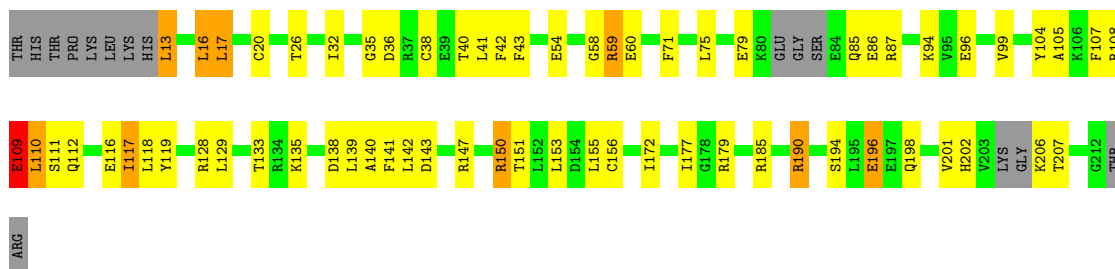

- Molecule 1: cAMP-activated global transcriptional regulator Vfr

Chain C: 

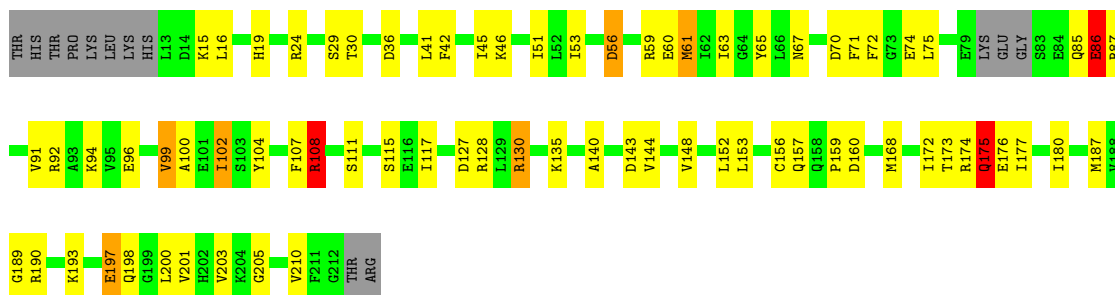

- Molecule 1: cAMP-activated global transcriptional regulator Vfr



4 Data and refinement statistics

Property	Value	Source
Space group	P 1	Depositor
Cell constants a, b, c, α , β , γ	49.74Å 87.61Å 104.97Å 79.04° 77.87° 75.40°	Depositor
Resolution (Å)	46.53 – 2.40 46.53 – 2.40	Depositor EDS
% Data completeness (in resolution range)	93.9 (46.53-2.40) 83.4 (46.53-2.40)	Depositor EDS
R_{merge}	(Not available)	Depositor
R_{sym}	(Not available)	Depositor
$\langle I/\sigma(I) \rangle$ ¹	83.78 (at 2.39Å)	Xtrriage
Refinement program	PHENIX 1.19.2_4158	Depositor
R, R_{free}	0.264 , 0.293 0.273 , 0.298	Depositor DCC
R_{free} test set	3123 reflections (3.73%)	wwPDB-VP
Wilson B-factor (Å ²)	29.8	Xtrriage
Anisotropy	0.439	Xtrriage
Bulk solvent k_{sol} (e/Å ³), B_{sol} (Å ²)	0.42 , 43.8	EDS
L-test for twinning ²	$\langle L \rangle = 0.47$, $\langle L^2 \rangle = 0.30$	Xtrriage
Estimated twinning fraction	0.055 for h,h-k,h-l	Xtrriage
F_o, F_c correlation	0.95	EDS
Total number of atoms	23885	wwPDB-VP
Average B, all atoms (Å ²)	31.0	wwPDB-VP

Xtrriage's analysis on translational NCS is as follows: *The analyses of the Patterson function reveals a significant off-origin peak that is 35.96 % of the origin peak, indicating pseudo-translational symmetry. The chance of finding a peak of this or larger height randomly in a structure without pseudo-translational symmetry is equal to 5.3798e-04. The detected translational NCS is most likely also responsible for the elevated intensity ratio.*

¹Intensities estimated from amplitudes.

²Theoretical values of $\langle |L| \rangle$, $\langle L^2 \rangle$ for acentric reflections are 0.5, 0.333 respectively for untwinned datasets, and 0.375, 0.2 for perfectly twinned datasets.

5 Model quality i

5.1 Standard geometry i

Bond lengths and bond angles in the following residue types are not validated in this section: SO4, AU, CL, CMP

The Z score for a bond length (or angle) is the number of standard deviations the observed value is removed from the expected value. A bond length (or angle) with $|Z| > 5$ is considered an outlier worth inspection. RMSZ is the root-mean-square of all Z scores of the bond lengths (or angles).

Mol	Chain	Bond lengths		Bond angles	
		RMSZ	# Z >5	RMSZ	# Z >5
1	A	0.29	0/1482	0.65	6/1999 (0.3%)
1	B	0.37	0/1482	0.79	9/1999 (0.5%)
1	C	0.56	1/1500 (0.1%)	0.94	15/2020 (0.7%)
1	D	0.43	3/1486 (0.2%)	0.85	9/2008 (0.4%)
1	E	0.48	3/1456 (0.2%)	0.93	15/1965 (0.8%)
1	F	0.87	8/1413 (0.6%)	1.24	17/1907 (0.9%)
1	G	0.20	0/1525	0.45	0/2050
1	H	0.28	0/1411	0.54	3/1904 (0.2%)
All	All	0.47	15/11755 (0.1%)	0.83	74/15852 (0.5%)

Chiral center outliers are detected by calculating the chiral volume of a chiral center and verifying if the center is modelled as a planar moiety or with the opposite hand. A planarity outlier is detected by checking planarity of atoms in a peptide group, atoms in a mainchain group or atoms of a sidechain that are expected to be planar.

Mol	Chain	#Chirality outliers	#Planarity outliers
1	A	0	1
1	B	0	2
1	C	0	5
1	D	0	1
1	E	0	2
1	F	0	5
All	All	0	16

The worst 5 of 15 bond length outliers are listed below:

Mol	Chain	Res	Type	Atoms	Z	Observed(Å)	Ideal(Å)
1	F	176	GLU	CG-CD	19.66	2.01	1.52
1	F	119	TYR	CA-CB	11.61	1.73	1.53
1	D	57	ASP	CG-OD2	8.18	1.40	1.25
1	E	150	ARG	CD-NE	-7.63	1.35	1.46

Continued on next page...

Continued from previous page...

Mol	Chain	Res	Type	Atoms	Z	Observed(Å)	Ideal(Å)
1	D	57	ASP	CG-OD1	7.40	1.39	1.25

The worst 5 of 74 bond angle outliers are listed below:

Mol	Chain	Res	Type	Atoms	Z	Observed(°)	Ideal(°)
1	D	57	ASP	CB-CG-OD2	-20.33	71.64	118.40
1	F	119	TYR	N-CA-CB	-19.13	78.15	110.49
1	F	119	TYR	CA-CB-CG	17.63	145.63	113.90
1	D	57	ASP	CB-CG-OD1	15.10	153.14	118.40
1	F	119	TYR	CB-CA-C	14.64	139.55	110.42

There are no chirality outliers.

5 of 16 planarity outliers are listed below:

Mol	Chain	Res	Type	Group
1	A	111	SER	Peptide
1	B	109	GLU	Sidechain
1	B	59	ARG	Peptide
1	C	108	ARG	Sidechain
1	C	86	GLU	Peptide

5.2 Too-close contacts [i](#)

In the following table, the Non-H and H(model) columns list the number of non-hydrogen atoms and hydrogen atoms in the chain respectively. The H(added) column lists the number of hydrogen atoms added and optimized by MolProbity. The Clashes column lists the number of clashes within the asymmetric unit, whereas Symm-Clashes lists symmetry-related clashes.

Mol	Chain	Non-H	H(model)	H(added)	Clashes	Symm-Clashes
1	A	1464	1413	1412	53	0
1	B	1465	1412	1410	57	1
1	C	1483	1452	1451	78	0
1	D	1467	1406	1406	61	0
1	E	1439	1389	1389	53	1
1	F	1397	1347	1347	55	1
1	G	1508	1495	1495	64	0
1	H	1395	1353	1352	45	0
2	A	22	11	11	1	0
2	B	22	11	11	2	0
2	C	22	11	11	2	0
2	D	22	11	11	1	0

Continued on next page...

Continued from previous page...

Mol	Chain	Non-H	H(model)	H(added)	Clashes	Symm-Clashes
2	E	22	11	11	2	0
2	F	22	11	11	1	0
2	G	22	11	11	1	0
2	H	22	11	11	1	0
3	A	4	0	0	0	1
3	B	5	0	0	1	0
3	C	5	0	0	0	0
3	D	4	0	0	0	0
3	E	4	0	0	0	1
3	F	3	0	0	0	0
3	G	3	0	0	0	0
3	H	3	0	0	0	0
4	A	2	0	0	2	1
4	B	3	0	0	5	0
4	C	2	0	0	6	0
4	D	2	0	0	2	0
4	E	1	0	0	2	0
4	F	1	0	0	0	0
4	G	2	0	0	5	0
4	H	1	0	0	2	0
5	C	5	0	0	3	0
5	E	5	0	0	3	0
5	G	5	0	0	1	0
6	A	80	0	0	17	2
6	B	69	0	0	22	2
6	C	104	0	0	35	2
6	D	91	0	0	29	2
6	E	73	0	0	17	2
6	F	58	0	0	10	2
6	G	112	0	0	34	1
6	H	89	0	0	13	1
All	All	12530	11355	11350	473	10

The all-atom clashscore is defined as the number of clashes found per 1000 atoms (including hydrogen atoms). The all-atom clashscore for this structure is 21.

The worst 5 of 473 close contacts within the same asymmetric unit are listed below, sorted by their clash magnitude.

Atom-1	Atom-2	Interatomic distance (Å)	Clash overlap (Å)
1:D:162:MET:CB	1:D:162:MET:CG	1.74	1.59
2:F:301:CMP:C2	2:F:301:CMP:H2	0.97	1.50

Continued on next page...

Continued from previous page...

Atom-1	Atom-2	Interatomic distance (Å)	Clash overlap (Å)
2:H:301:CMP:H2	2:H:301:CMP:C2	0.97	1.50
2:D:301:CMP:C2	2:D:301:CMP:H2	0.97	1.49
2:A:301:CMP:C2	2:A:301:CMP:H2	0.97	1.47

The worst 5 of 10 symmetry-related close contacts are listed below. The label for Atom-2 includes the symmetry operator and encoded unit-cell translations to be applied.

Atom-1	Atom-2	Interatomic distance (Å)	Clash overlap (Å)
6:B:427:HOH:O	6:E:433:HOH:O[1_554]	1.80	0.40
6:A:460:HOH:O	6:E:453:HOH:O[1_554]	1.81	0.39
6:C:495:HOH:O	6:D:469:HOH:O[1_455]	1.83	0.37
6:C:495:HOH:O	6:D:470:HOH:O[1_455]	1.88	0.32
6:B:457:HOH:O	6:F:444:HOH:O[1_554]	1.95	0.25

5.3 Torsion angles [i](#)

5.3.1 Protein backbone [i](#)

In the following table, the Percentiles column shows the percent Ramachandran outliers of the chain as a percentile score with respect to all X-ray entries followed by that with respect to entries of similar resolution.

The Analysed column shows the number of residues for which the backbone conformation was analysed, and the total number of residues.

Mol	Chain	Analysed	Favoured	Allowed	Outliers	Percentiles	
1	A	193/210 (92%)	183 (95%)	8 (4%)	2 (1%)	12	20
1	B	189/210 (90%)	178 (94%)	10 (5%)	1 (0%)	24	37
1	C	193/210 (92%)	189 (98%)	4 (2%)	0	100	100
1	D	196/210 (93%)	184 (94%)	10 (5%)	2 (1%)	12	20
1	E	190/210 (90%)	179 (94%)	9 (5%)	2 (1%)	11	18
1	F	184/210 (88%)	170 (92%)	14 (8%)	0	100	100
1	G	193/210 (92%)	181 (94%)	10 (5%)	2 (1%)	12	20
1	H	182/210 (87%)	174 (96%)	6 (3%)	2 (1%)	11	18
All	All	1520/1680 (90%)	1438 (95%)	71 (5%)	11 (1%)	18	28

5 of 11 Ramachandran outliers are listed below:

Mol	Chain	Res	Type
1	A	112	GLN
1	D	19	HIS
1	H	158	GLN
1	H	159	PRO
1	G	17	LEU

5.3.2 Protein sidechains [i](#)

In the following table, the Percentiles column shows the percent sidechain outliers of the chain as a percentile score with respect to all X-ray entries followed by that with respect to entries of similar resolution.

The Analysed column shows the number of residues for which the sidechain conformation was analysed, and the total number of residues.

Mol	Chain	Analysed	Rotameric	Outliers	Percentiles
1	A	146/181 (81%)	141 (97%)	5 (3%)	32 54
1	B	149/181 (82%)	141 (95%)	8 (5%)	20 35
1	C	151/181 (83%)	145 (96%)	6 (4%)	28 47
1	D	147/181 (81%)	144 (98%)	3 (2%)	48 70
1	E	143/181 (79%)	140 (98%)	3 (2%)	47 69
1	F	139/181 (77%)	135 (97%)	4 (3%)	37 60
1	G	157/181 (87%)	145 (92%)	12 (8%)	12 21
1	H	142/181 (78%)	138 (97%)	4 (3%)	38 60
All	All	1174/1448 (81%)	1129 (96%)	45 (4%)	29 49

5 of 45 residues with a non-rotameric sidechain are listed below:

Mol	Chain	Res	Type
1	F	183	CYS
1	G	63	ILE
1	G	14	ASP
1	G	23	ARG
1	G	116	GLU

Sometimes sidechains can be flipped to improve hydrogen bonding and reduce clashes. 5 of 8 such sidechains are listed below:

Mol	Chain	Res	Type
1	E	175	GLN

Continued on next page...

Continued from previous page...

Mol	Chain	Res	Type
1	D	198	GLN
1	B	112	GLN
1	B	67	ASN
1	B	169	GLN

5.3.3 RNA [i](#)

There are no RNA molecules in this entry.

5.4 Non-standard residues in protein, DNA, RNA chains [i](#)

There are no non-standard protein/DNA/RNA residues in this entry.

5.5 Carbohydrates [i](#)

There are no oligosaccharides in this entry.

5.6 Ligand geometry [i](#)

Of 56 ligands modelled in this entry, 45 are monoatomic - leaving 11 for Mogul analysis.

In the following table, the Counts columns list the number of bonds (or angles) for which Mogul statistics could be retrieved, the number of bonds (or angles) that are observed in the model and the number of bonds (or angles) that are defined in the Chemical Component Dictionary. The Link column lists molecule types, if any, to which the group is linked. The Z score for a bond length (or angle) is the number of standard deviations the observed value is removed from the expected value. A bond length (or angle) with $|Z| > 2$ is considered an outlier worth inspection. RMSZ is the root-mean-square of all Z scores of the bond lengths (or angles).

Mol	Type	Chain	Res	Link	Bond lengths			Bond angles		
					Counts	RMSZ	# Z > 2	Counts	RMSZ	# Z > 2
2	CMP	B	301	-	25,25,25	1.72	9 (36%)	37,39,39	2.11	12 (32%)
2	CMP	G	301	-	25,25,25	1.74	8 (32%)	37,39,39	2.06	11 (29%)
2	CMP	F	301	-	25,25,25	1.71	9 (36%)	37,39,39	2.07	11 (29%)
5	SO4	C	302	-	4,4,4	0.22	0	6,6,6	0.18	0
2	CMP	A	301	-	25,25,25	1.70	9 (36%)	37,39,39	2.11	11 (29%)
5	SO4	G	302	-	4,4,4	0.22	0	6,6,6	0.10	0
2	CMP	E	301	-	25,25,25	1.74	8 (32%)	37,39,39	2.05	12 (32%)
5	SO4	E	302	-	4,4,4	0.23	0	6,6,6	0.07	0

Mol	Type	Chain	Res	Link	Bond lengths			Bond angles		
					Counts	RMSZ	# Z > 2	Counts	RMSZ	# Z > 2
2	CMP	H	301	-	25,25,25	1.74	9 (36%)	37,39,39	2.06	11 (29%)
2	CMP	C	301	-	25,25,25	1.71	9 (36%)	37,39,39	2.09	12 (32%)
2	CMP	D	301	-	25,25,25	1.73	9 (36%)	37,39,39	2.08	12 (32%)

In the following table, the Chirals column lists the number of chiral outliers, the number of chiral centers analysed, the number of these observed in the model and the number defined in the Chemical Component Dictionary. Similar counts are reported in the Torsion and Rings columns. '-' means no outliers of that kind were identified.

Mol	Type	Chain	Res	Link	Chirals	Torsions	Rings
2	CMP	B	301	-	-	0/4/31/31	0/4/4/4
2	CMP	G	301	-	-	0/4/31/31	0/4/4/4
2	CMP	F	301	-	-	0/4/31/31	0/4/4/4
2	CMP	A	301	-	-	0/4/31/31	0/4/4/4
2	CMP	E	301	-	-	0/4/31/31	0/4/4/4
2	CMP	H	301	-	-	0/4/31/31	0/4/4/4
2	CMP	C	301	-	-	0/4/31/31	0/4/4/4
2	CMP	D	301	-	-	0/4/31/31	0/4/4/4

The worst 5 of 70 bond length outliers are listed below:

Mol	Chain	Res	Type	Atoms	Z	Observed(Å)	Ideal(Å)
2	D	301	CMP	C5-C4	4.46	1.47	1.39
2	E	301	CMP	C5-C4	4.45	1.47	1.39
2	H	301	CMP	C5-C4	4.45	1.47	1.39
2	G	301	CMP	C5-C4	4.45	1.47	1.39
2	B	301	CMP	C5-C4	4.34	1.46	1.39

The worst 5 of 92 bond angle outliers are listed below:

Mol	Chain	Res	Type	Atoms	Z	Observed(°)	Ideal(°)
2	B	301	CMP	C5-C4-N3	-5.70	118.88	126.72
2	A	301	CMP	C5-C4-N3	-5.66	118.93	126.72
2	G	301	CMP	C5-C4-N3	-5.63	118.97	126.72
2	F	301	CMP	C5-C4-N3	-5.61	118.99	126.72
2	H	301	CMP	C5-C4-N3	-5.59	119.02	126.72

There are no chirality outliers.

There are no torsion outliers.

There are no ring outliers.

11 monomers are involved in 18 short contacts:

Mol	Chain	Res	Type	Clashes	Symm-Clashes
2	B	301	CMP	2	0
2	G	301	CMP	1	0
2	F	301	CMP	1	0
5	C	302	SO4	3	0
2	A	301	CMP	1	0
5	G	302	SO4	1	0
2	E	301	CMP	2	0
5	E	302	SO4	3	0
2	H	301	CMP	1	0
2	C	301	CMP	2	0
2	D	301	CMP	1	0

The following is a two-dimensional graphical depiction of Mogul quality analysis of bond lengths, bond angles, torsion angles, and ring geometry for all instances of the Ligand of Interest. In addition, ligands with molecular weight > 250 and outliers as shown on the validation Tables will also be included. For torsion angles, if less than 5% of the Mogul distribution of torsion angles is within 10 degrees of the torsion angle in question, then that torsion angle is considered an outlier. Any bond that is central to one or more torsion angles identified as an outlier by Mogul will be highlighted in the graph. For rings, the root-mean-square deviation (RMSD) between the ring in question and similar rings identified by Mogul is calculated over all ring torsion angles. If the average RMSD is greater than 60 degrees and the minimal RMSD between the ring in question and any Mogul-identified rings is also greater than 60 degrees, then that ring is considered an outlier. The outliers are highlighted in purple. The color gray indicates Mogul did not find sufficient equivalents in the CSD to analyse the geometry.

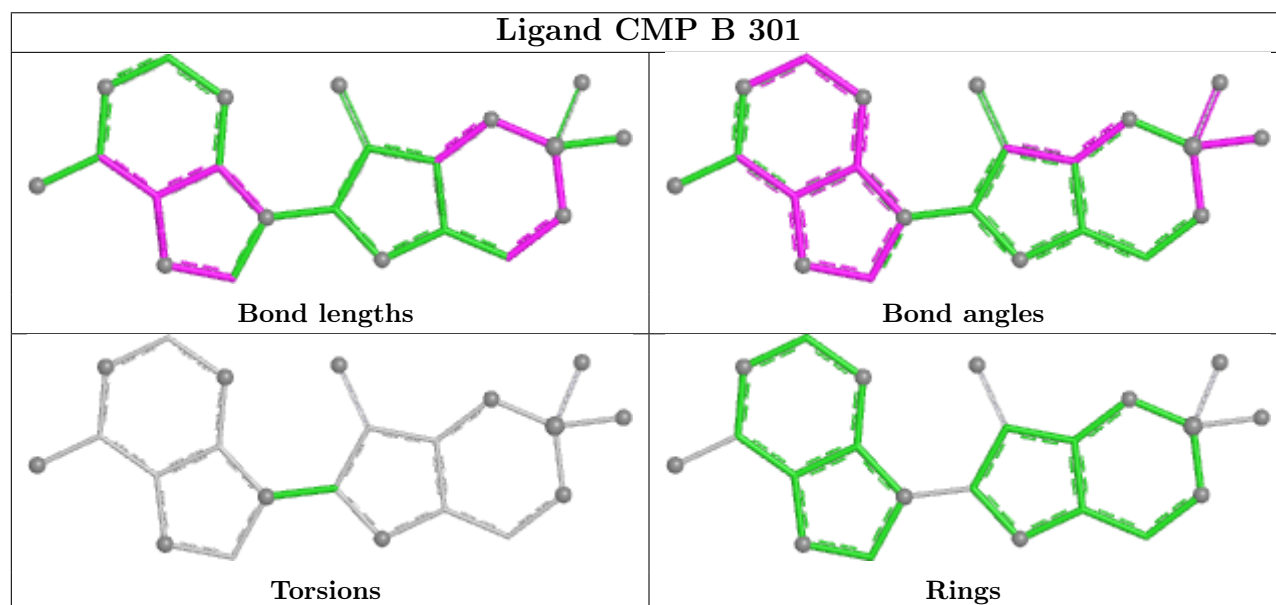

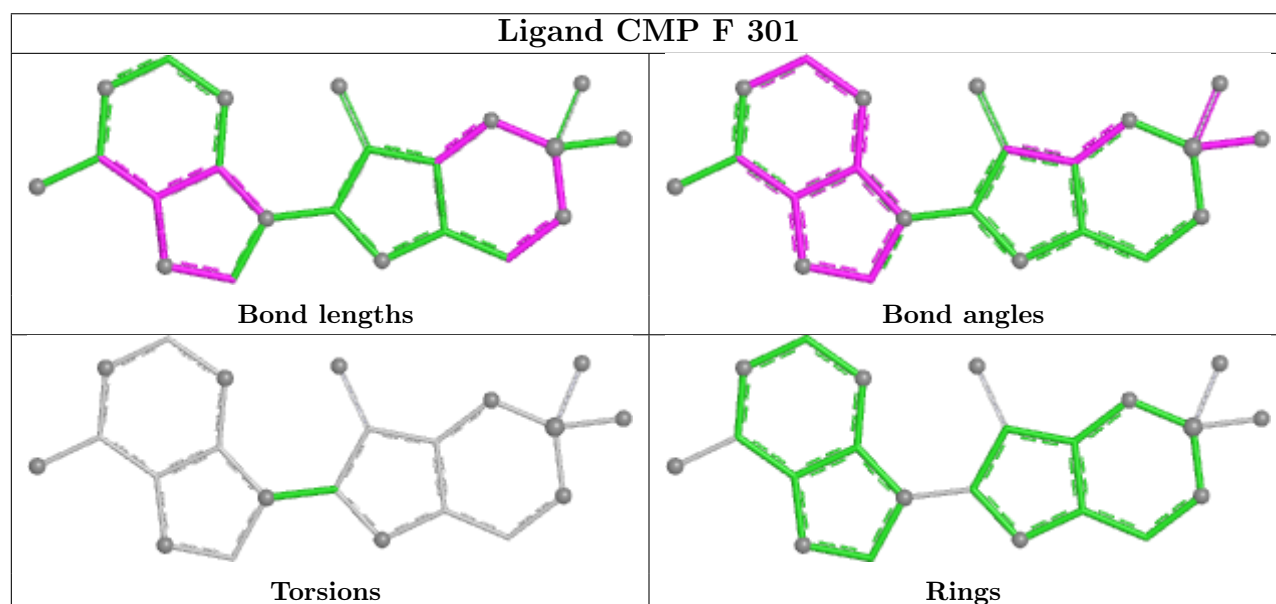
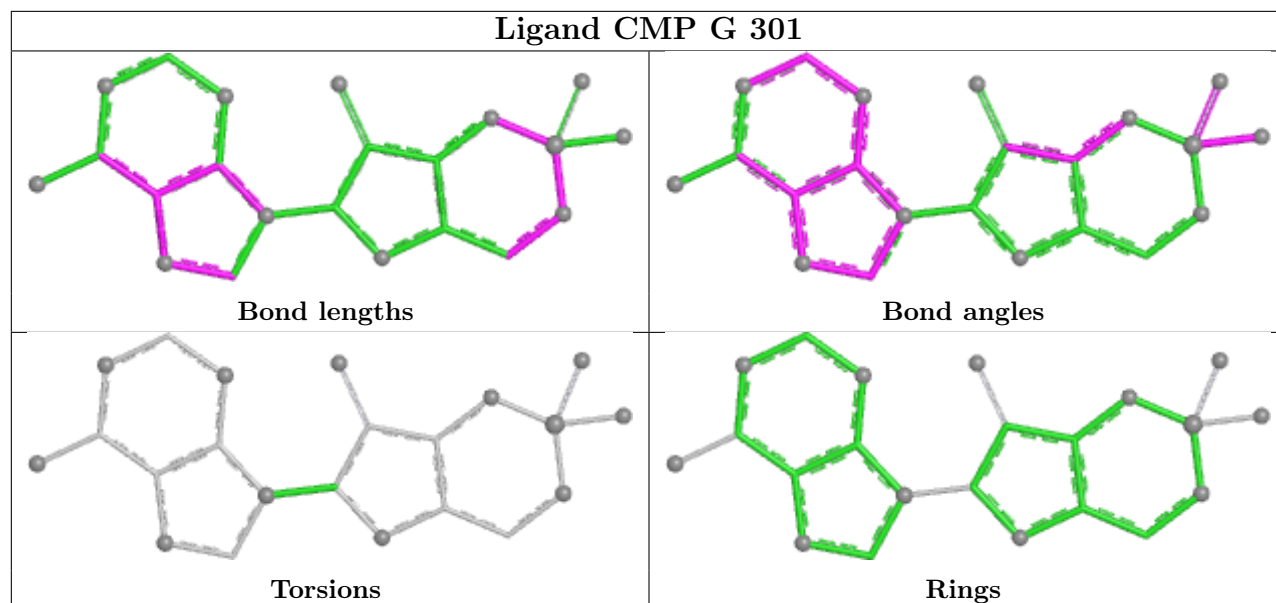

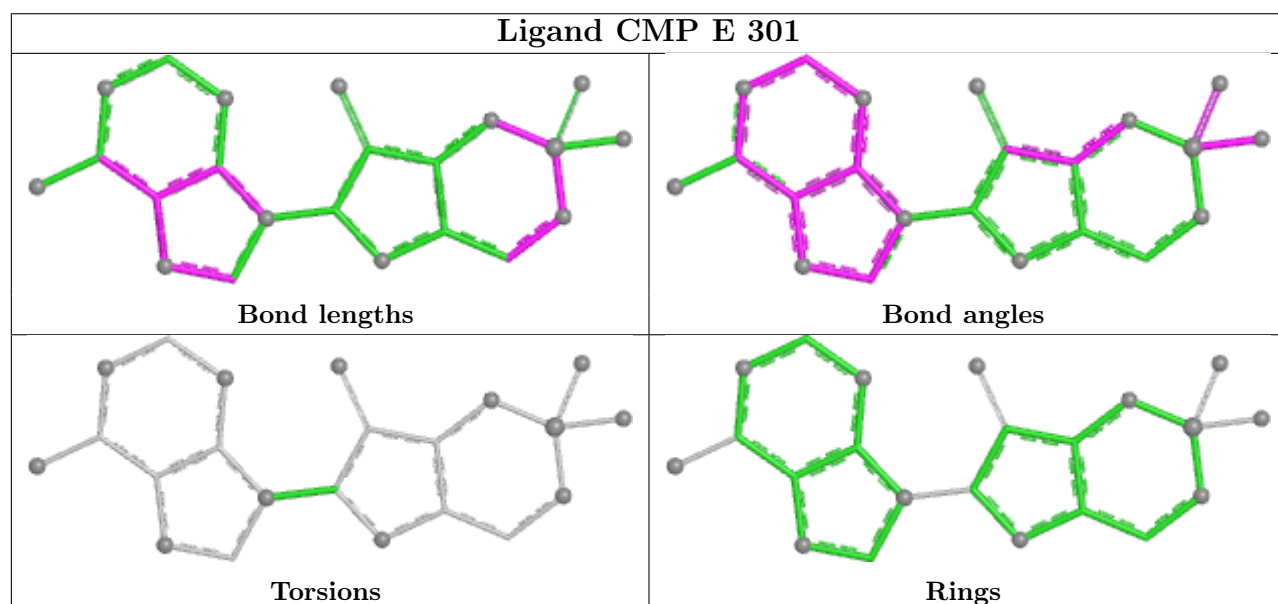
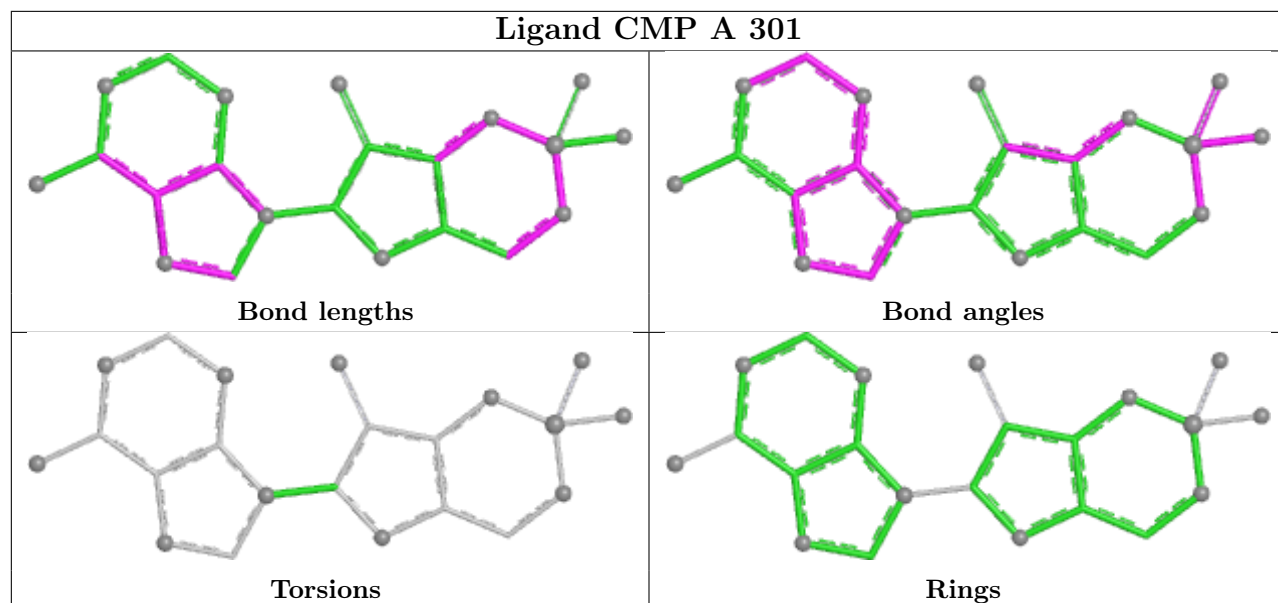

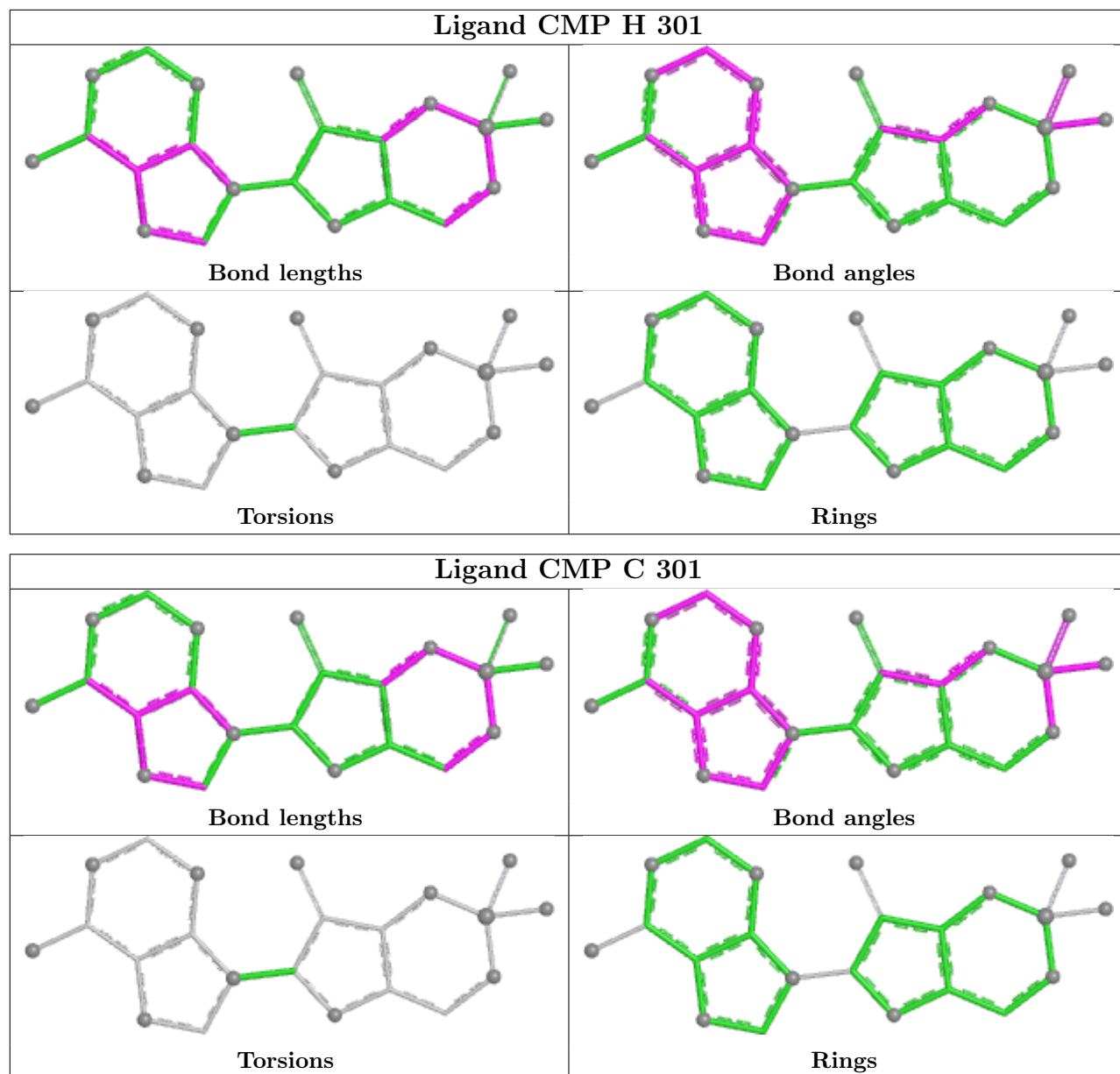

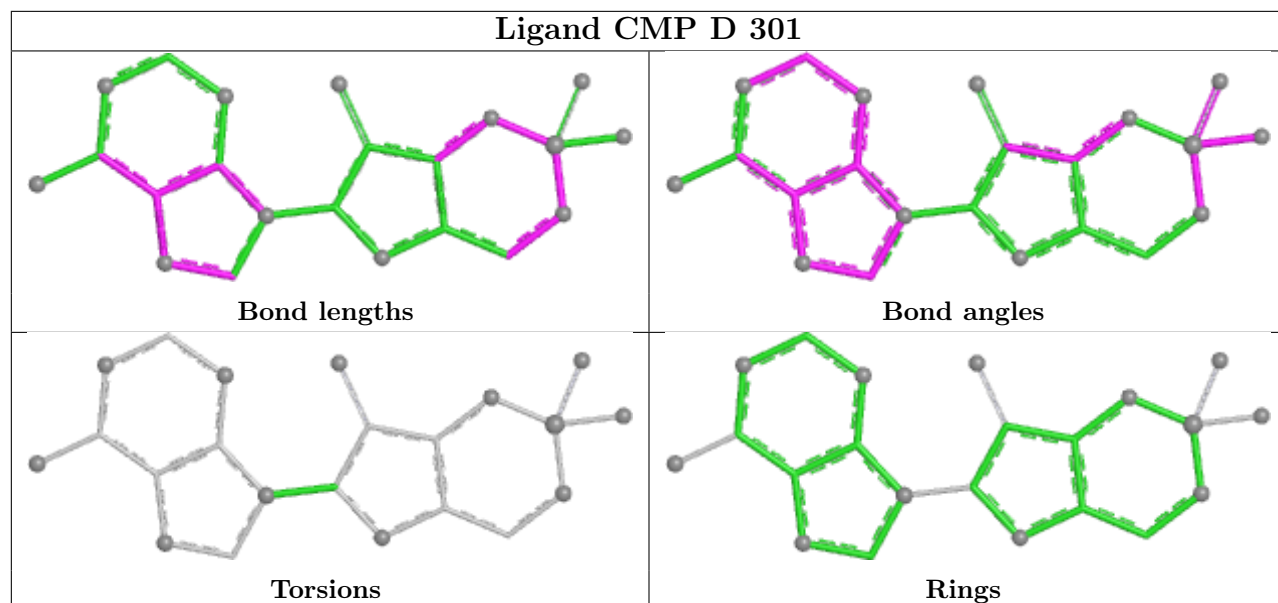

5.7 Other polymers [i](#)

There are no such residues in this entry.

5.8 Polymer linkage issues [i](#)

There are no chain breaks in this entry.

6 Fit of model and data [i](#)

6.1 Protein, DNA and RNA chains [i](#)

In the following table, the column labelled ‘#RSRZ> 2’ contains the number (and percentage) of RSRZ outliers, followed by percent RSRZ outliers for the chain as percentile scores relative to all X-ray entries and entries of similar resolution. The OWAB column contains the minimum, median, 95th percentile and maximum values of the occupancy-weighted average B-factor per residue. The column labelled ‘Q< 0.9’ lists the number of (and percentage) of residues with an average occupancy less than 0.9.

Mol	Chain	Analysed	<RSRZ>	#RSRZ>2	OWAB(Å ²)	Q<0.9
1	A	197/210 (93%)	-1.10	0 100 100	20, 29, 48, 64	0
1	B	195/210 (92%)	-1.00	0 100 100	21, 34, 51, 61	0
1	C	197/210 (93%)	-1.15	0 100 100	17, 27, 46, 54	0
1	D	198/210 (94%)	-1.09	0 100 100	19, 30, 52, 71	0
1	E	194/210 (92%)	-1.14	0 100 100	19, 29, 47, 54	0
1	F	188/210 (89%)	-0.86	1 (0%) 87 85	21, 36, 67, 85	0
1	G	197/210 (93%)	-1.18	0 100 100	17, 26, 45, 71	0
1	H	186/210 (88%)	-1.16	0 100 100	18, 28, 44, 56	0
All	All	1552/1680 (92%)	-1.08	1 (0%) 92 90	17, 29, 52, 85	0

All (1) RSRZ outliers are listed below:

Mol	Chain	Res	Type	RSRZ
1	F	161	ALA	2.1

6.2 Non-standard residues in protein, DNA, RNA chains [i](#)

There are no non-standard protein/DNA/RNA residues in this entry.

6.3 Carbohydrates [i](#)

There are no oligosaccharides in this entry.

6.4 Ligands [i](#)

In the following table, the Atoms column lists the number of modelled atoms in the group and the number defined in the chemical component dictionary. The B-factors column lists the minimum,

median, 95th percentile and maximum values of B factors of atoms in the group. The column labelled 'Q< 0.9' lists the number of atoms with occupancy less than 0.9.

Mol	Type	Chain	Res	Atoms	RSCC	RSR	B-factors(Å ²)	Q<0.9
3	AU	D	305	1/1	0.97	0.05	137,137,137,137	0
3	AU	F	304	1/1	0.98	0.07	141,141,141,141	0
4	CL	B	307	1/1	0.98	0.08	52,52,52,52	0
4	CL	C	309	1/1	0.98	0.05	54,54,54,54	0
4	CL	G	306	1/1	0.98	0.09	41,41,41,41	0
4	CL	H	305	1/1	0.98	0.09	43,43,43,43	0
2	CMP	H	301	22/22	0.99	0.03	16,19,25,27	0
3	AU	B	303	1/1	0.99	0.07	111,111,111,111	0
3	AU	B	304	1/1	0.99	0.03	96,96,96,96	0
3	AU	B	306	1/1	0.99	0.04	114,114,114,114	0
3	AU	C	305	1/1	0.99	0.09	119,119,119,119	0
3	AU	D	303	1/1	0.99	0.08	110,110,110,110	0
2	CMP	A	301	22/22	0.99	0.03	16,19,23,27	0
3	AU	E	303	1/1	0.99	0.08	119,119,119,119	0
3	AU	E	305	1/1	0.99	0.02	60,60,60,60	0
2	CMP	B	301	22/22	0.99	0.03	17,19,23,27	0
3	AU	H	303	1/1	0.99	0.05	123,123,123,123	0
2	CMP	C	301	22/22	0.99	0.03	15,19,26,27	0
4	CL	C	308	1/1	0.99	0.03	34,34,34,34	0
2	CMP	D	301	22/22	0.99	0.03	17,19,22,23	0
4	CL	D	307	1/1	0.99	0.08	43,43,43,43	0
2	CMP	F	301	22/22	0.99	0.03	17,20,23,29	0
4	CL	G	307	1/1	0.99	0.05	51,51,51,51	0
2	CMP	G	301	22/22	0.99	0.03	13,18,24,29	0
5	SO4	C	302	5/5	0.99	0.09	30,30,38,41	0
5	SO4	E	302	5/5	0.99	0.06	28,33,38,39	0
5	SO4	G	302	5/5	0.99	0.08	35,43,47,53	0
3	AU	E	304	1/1	1.00	0.07	82,82,82,82	0
3	AU	A	302	1/1	1.00	0.02	59,59,59,59	0
3	AU	E	306	1/1	1.00	0.01	46,46,46,46	0
3	AU	F	302	1/1	1.00	0.04	103,103,103,103	0
3	AU	F	303	1/1	1.00	0.02	47,47,47,47	0
3	AU	B	305	1/1	1.00	0.01	52,52,52,52	0
3	AU	G	303	1/1	1.00	0.02	52,52,52,52	0
3	AU	G	304	1/1	1.00	0.04	49,49,49,49	0
3	AU	G	305	1/1	1.00	0.01	26,26,26,26	0
3	AU	H	302	1/1	1.00	0.02	38,38,38,38	0
3	AU	A	303	1/1	1.00	0.02	56,56,56,56	0
3	AU	H	304	1/1	1.00	0.04	65,65,65,65	0
4	CL	A	306	1/1	1.00	0.02	15,15,15,15	0
4	CL	A	307	1/1	1.00	0.04	40,40,40,40	0

Continued on next page...

Continued from previous page...

Mol	Type	Chain	Res	Atoms	RSCC	RSR	B-factors(\AA^2)	Q<0.9
3	AU	C	303	1/1	1.00	0.02	64,64,64,64	0
4	CL	B	308	1/1	1.00	0.04	26,26,26,26	0
4	CL	B	309	1/1	1.00	0.02	47,47,47,47	0
3	AU	C	304	1/1	1.00	0.03	71,71,71,71	0
3	AU	A	304	1/1	1.00	0.04	85,85,85,85	0
4	CL	D	306	1/1	1.00	0.03	34,34,34,34	0
3	AU	C	306	1/1	1.00	0.04	90,90,90,90	0
4	CL	E	307	1/1	1.00	0.04	20,20,20,20	0
4	CL	F	305	1/1	1.00	0.02	32,32,32,32	0
3	AU	C	307	1/1	1.00	0.01	27,27,27,27	0
3	AU	D	302	1/1	1.00	0.02	42,42,42,42	0
3	AU	A	305	1/1	1.00	0.04	85,85,85,85	0
3	AU	D	304	1/1	1.00	0.04	53,53,53,53	0
3	AU	B	302	1/1	1.00	0.02	110,110,110,110	0
2	CMP	E	301	22/22	1.00	0.03	16,19,22,23	0

The following is a graphical depiction of the model fit to experimental electron density of all instances of the Ligand of Interest. In addition, ligands with molecular weight > 250 and outliers as shown on the geometry validation Tables will also be included. Each fit is shown from different orientation to approximate a three-dimensional view.

Electron density around AU D 305:

$2mF_o-DF_c$ (at 0.7 rmsd) in gray
 mF_o-DF_c (at 3 rmsd) in purple (negative)
and green (positive)

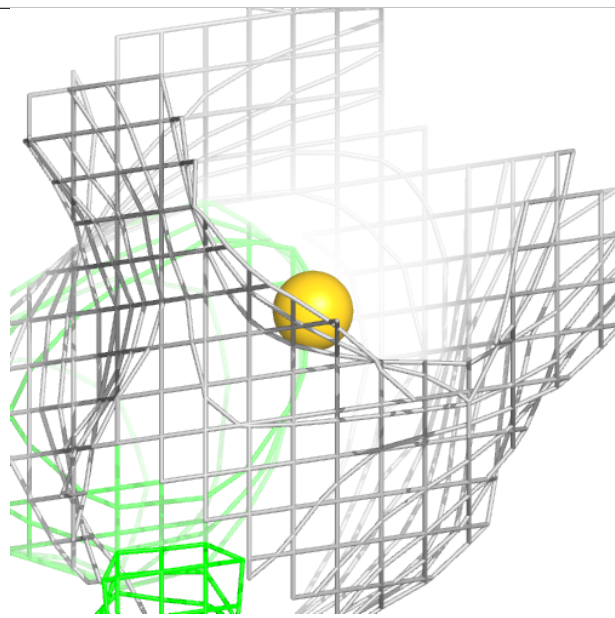
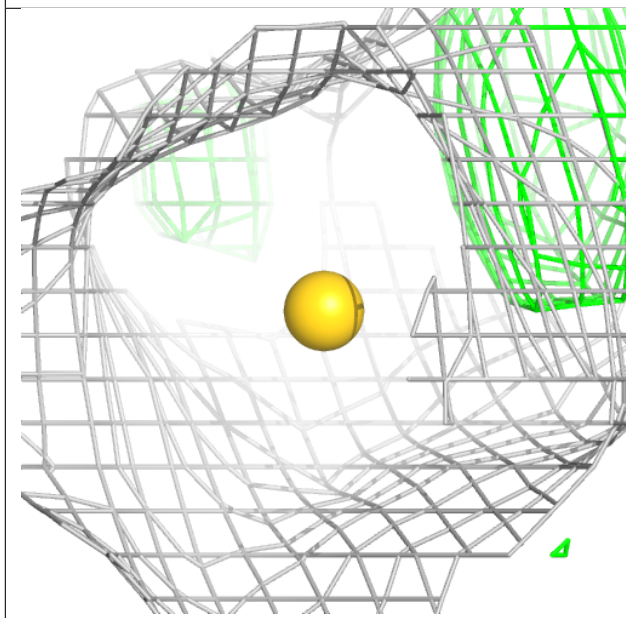
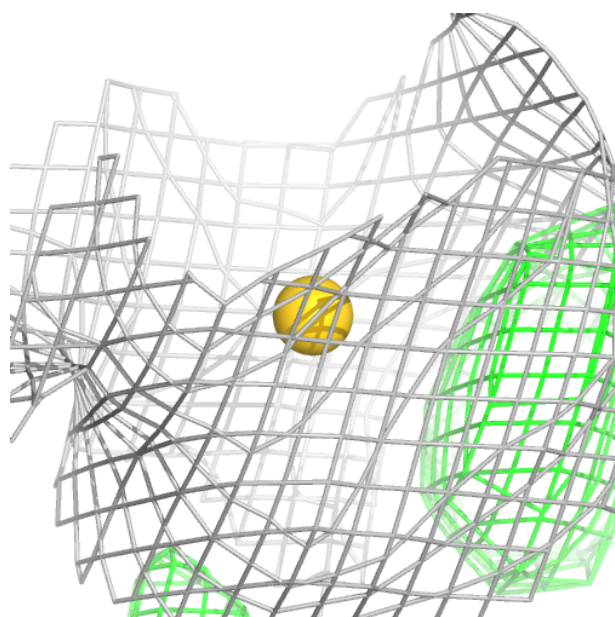

Electron density around AU F 304:

$2mF_o-DF_c$ (at 0.7 rmsd) in gray
 mF_o-DF_c (at 3 rmsd) in purple (negative)
and green (positive)

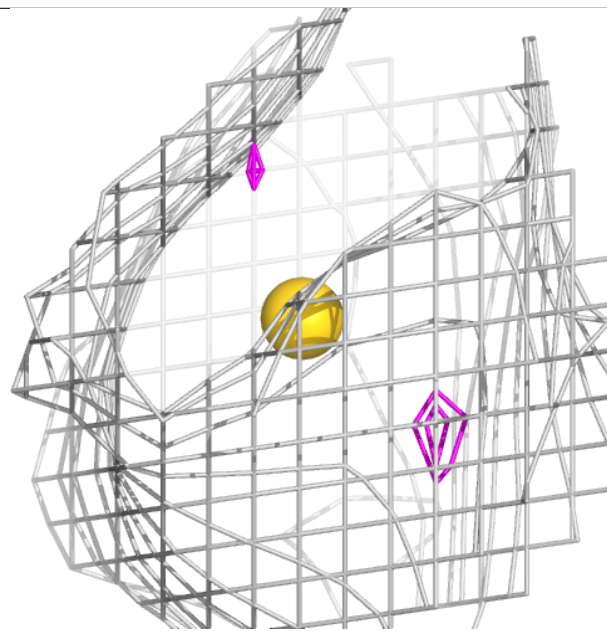
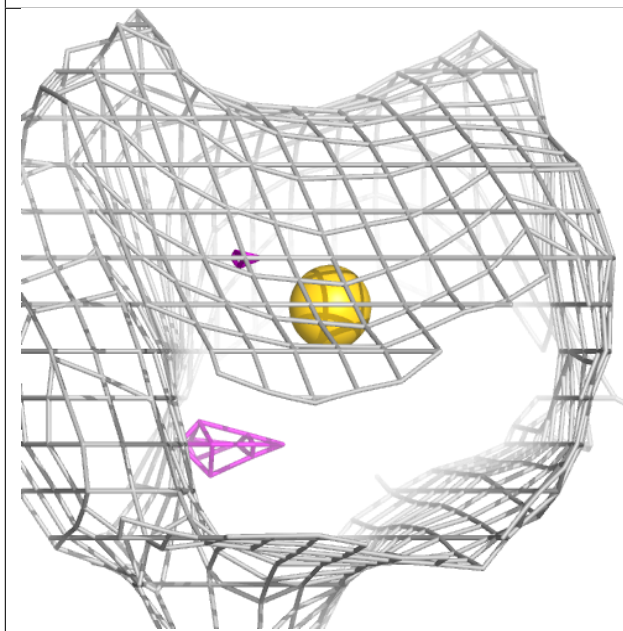
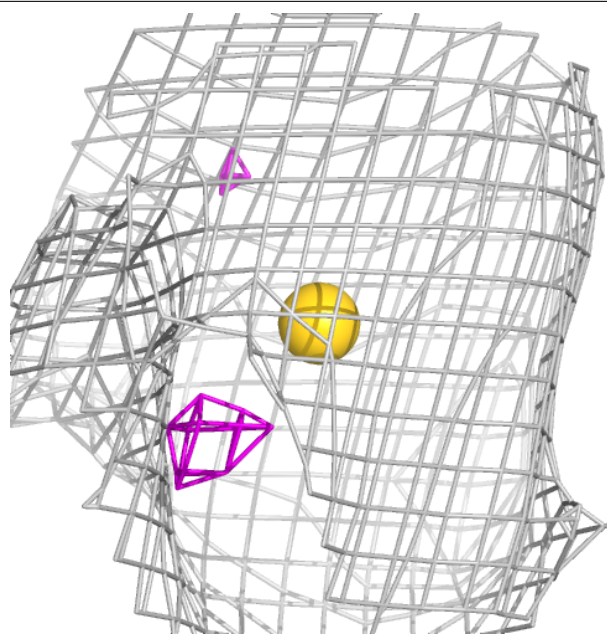

Electron density around CL B 307:

$2mF_o-DF_c$ (at 0.7 rmsd) in gray
 mF_o-DF_c (at 3 rmsd) in purple (negative)
and green (positive)

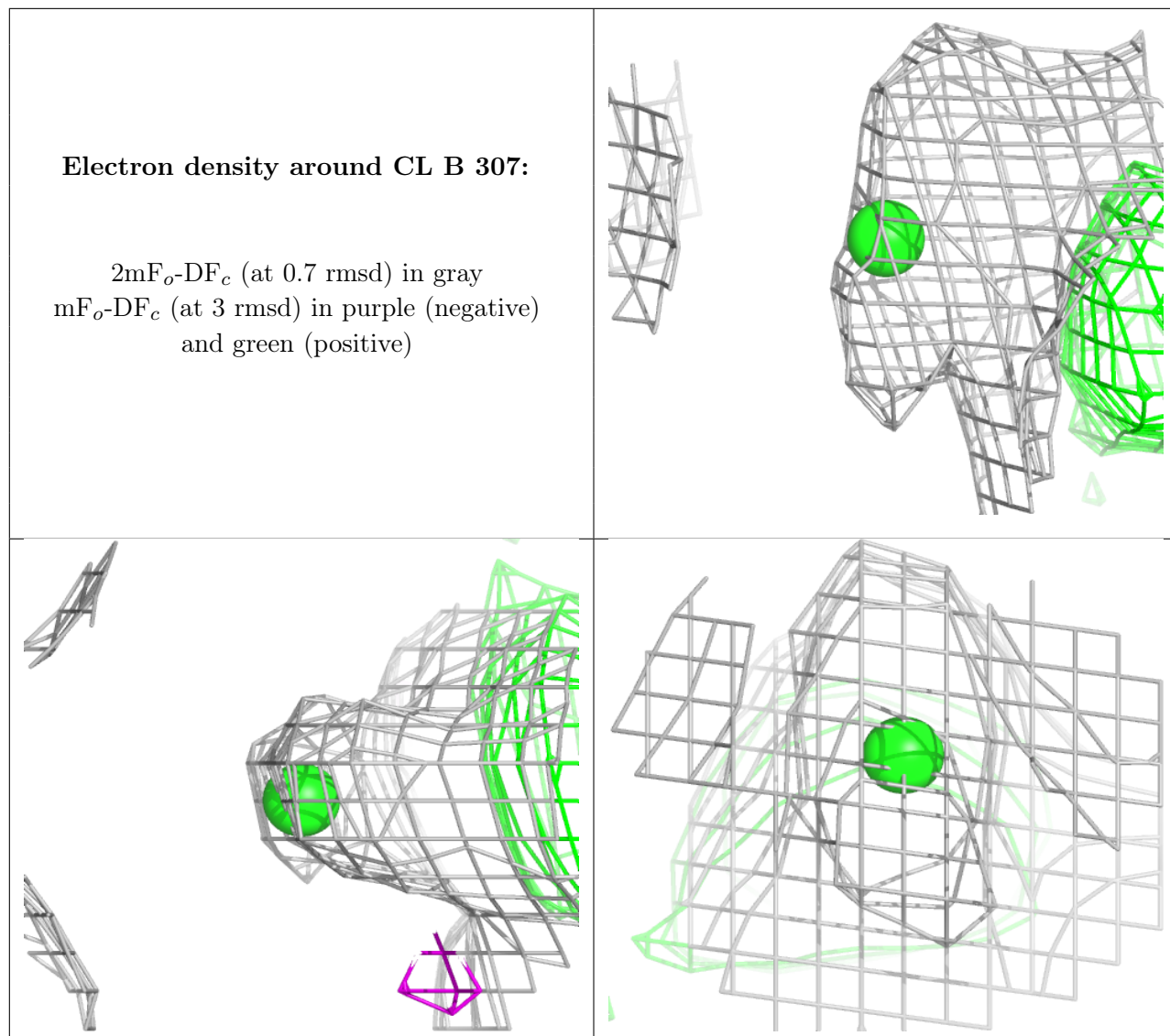

Electron density around CL C 309:

$2mF_o-DF_c$ (at 0.7 rmsd) in gray
 mF_o-DF_c (at 3 rmsd) in purple (negative)
and green (positive)

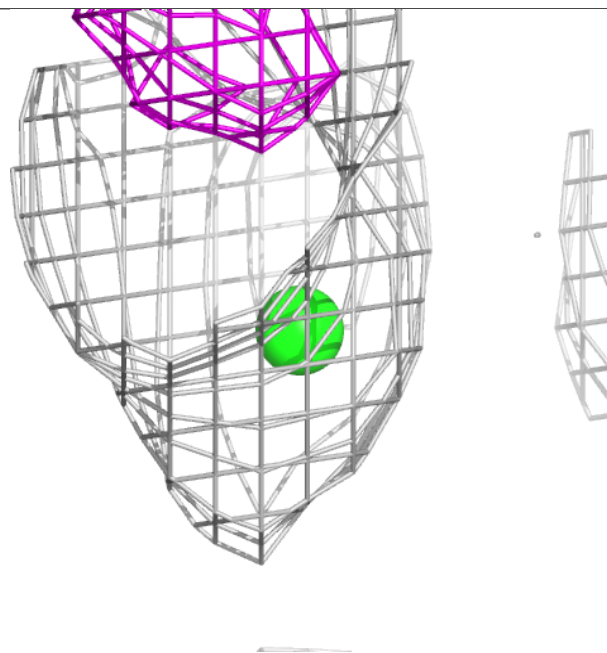
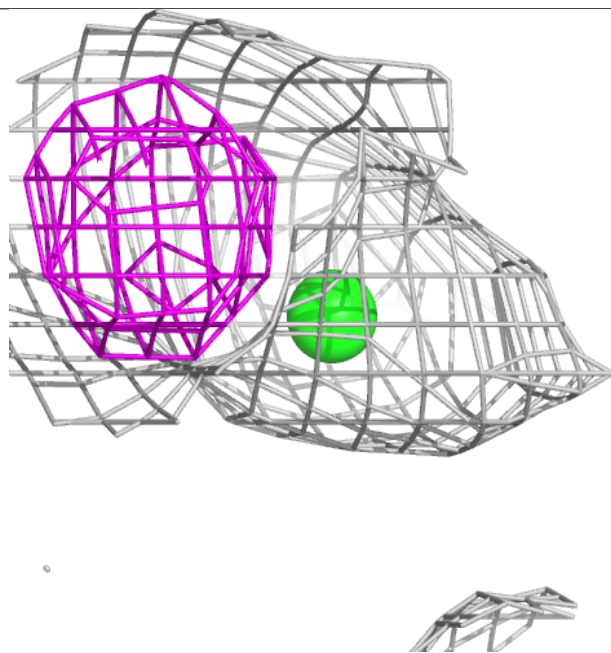
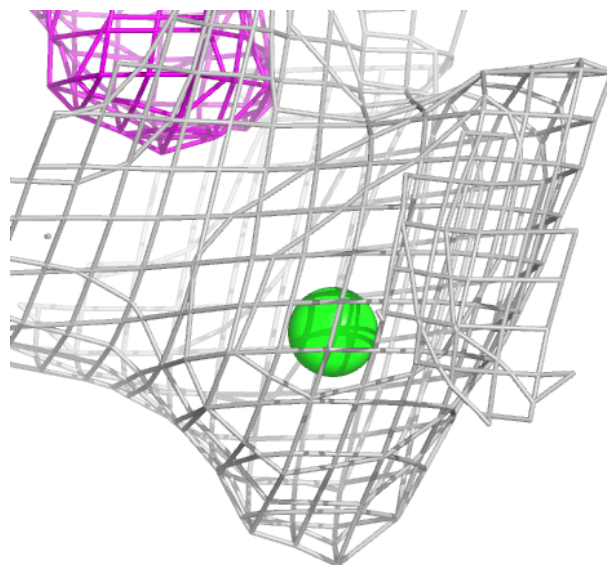

Electron density around CL G 306:

$2mF_o-DF_c$ (at 0.7 rmsd) in gray
 mF_o-DF_c (at 3 rmsd) in purple (negative)
and green (positive)

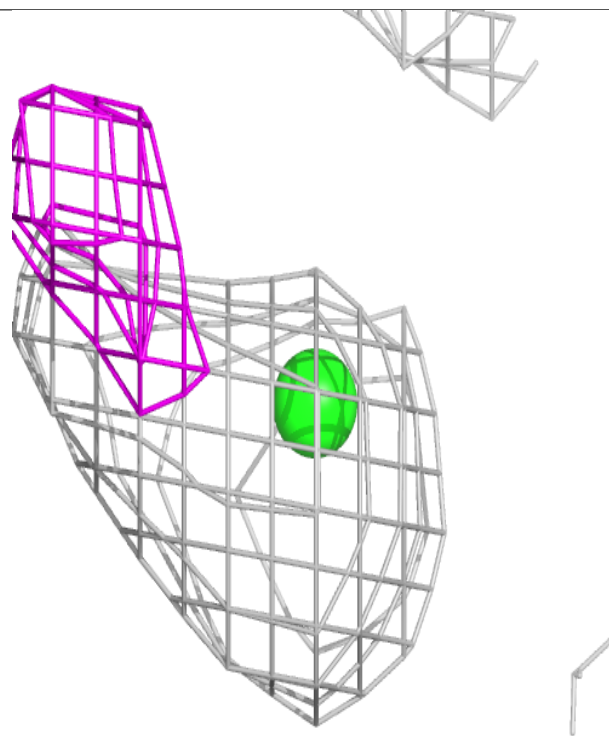
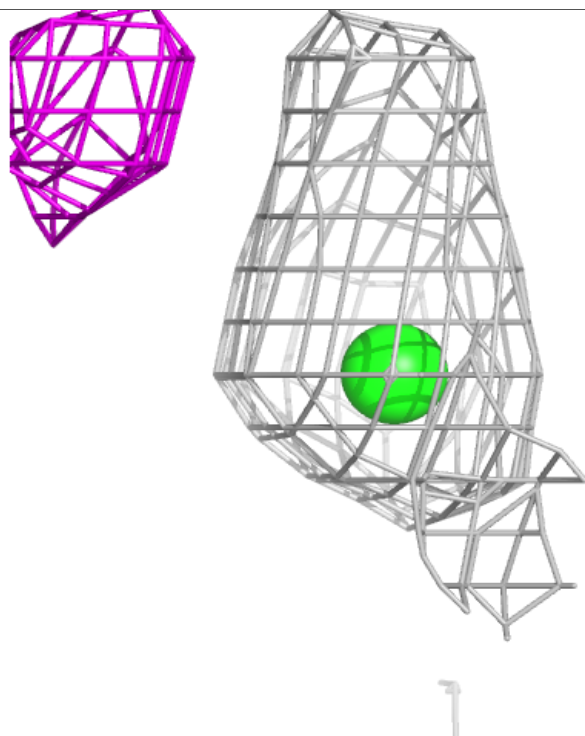
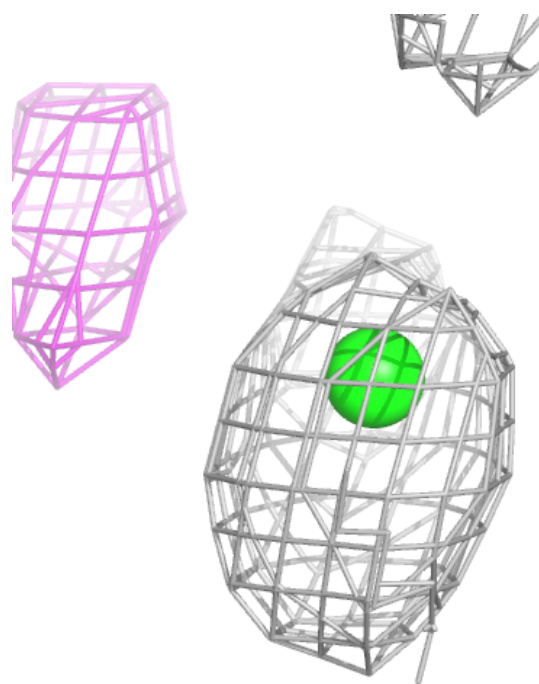

Electron density around CL H 305:

$2mF_o-DF_c$ (at 0.7 rmsd) in gray
 mF_o-DF_c (at 3 rmsd) in purple (negative)
and green (positive)

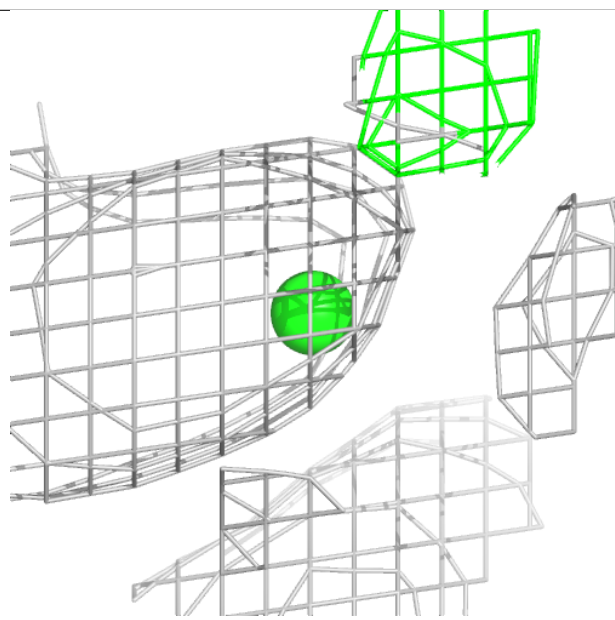
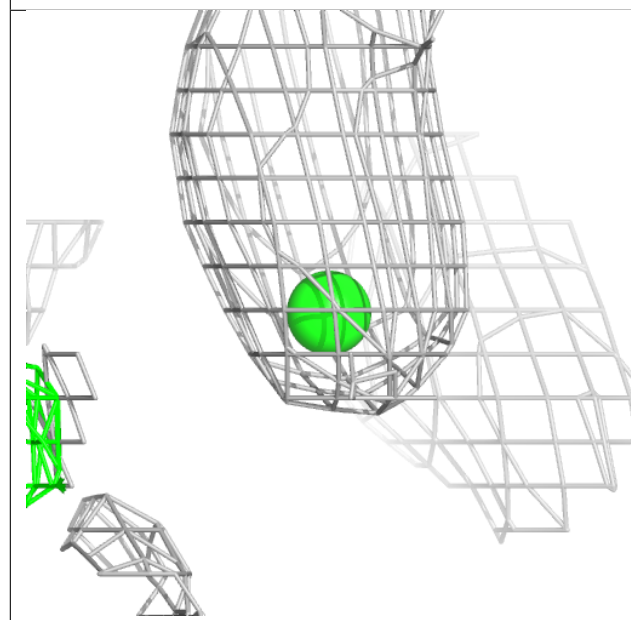
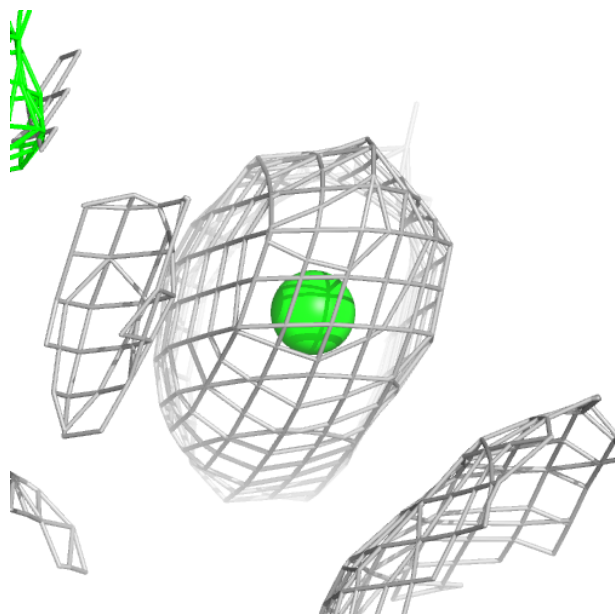

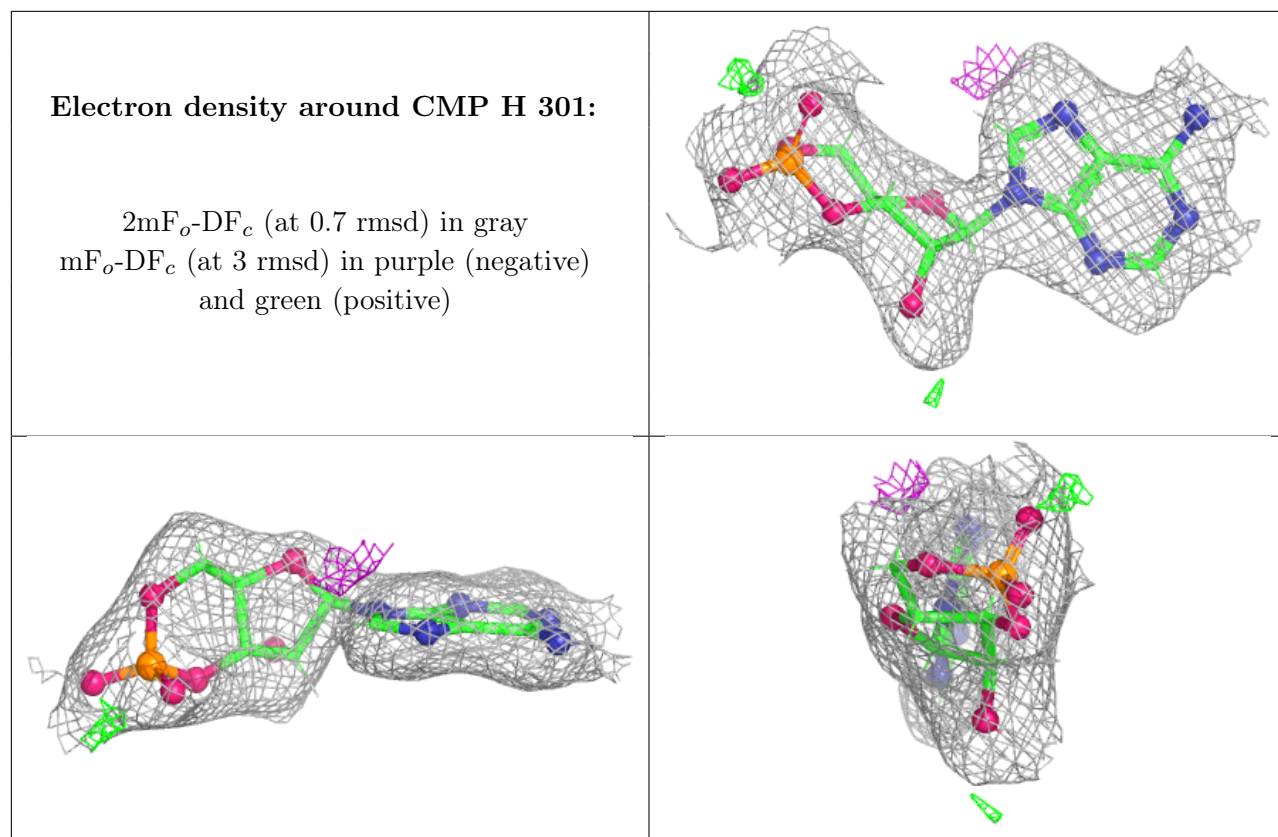

Electron density around AU B 303:

$2mF_o-DF_c$ (at 0.7 rmsd) in gray
 mF_o-DF_c (at 3 rmsd) in purple (negative)
and green (positive)

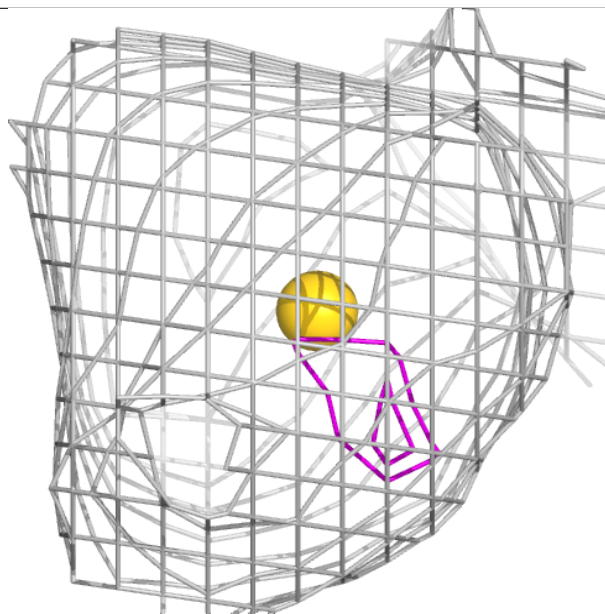
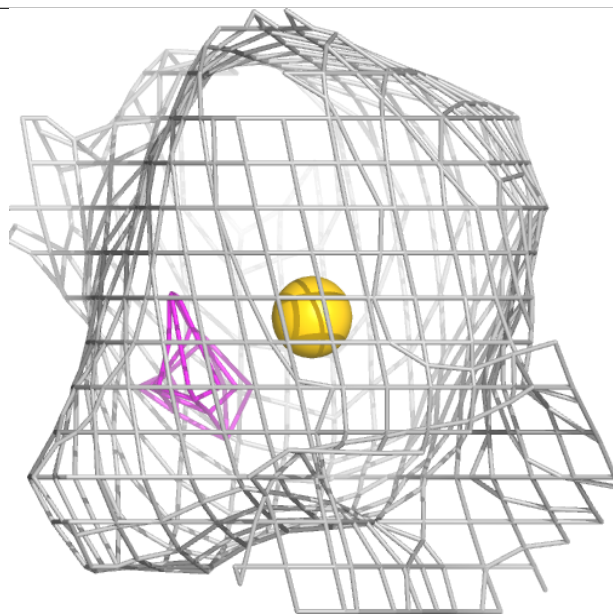
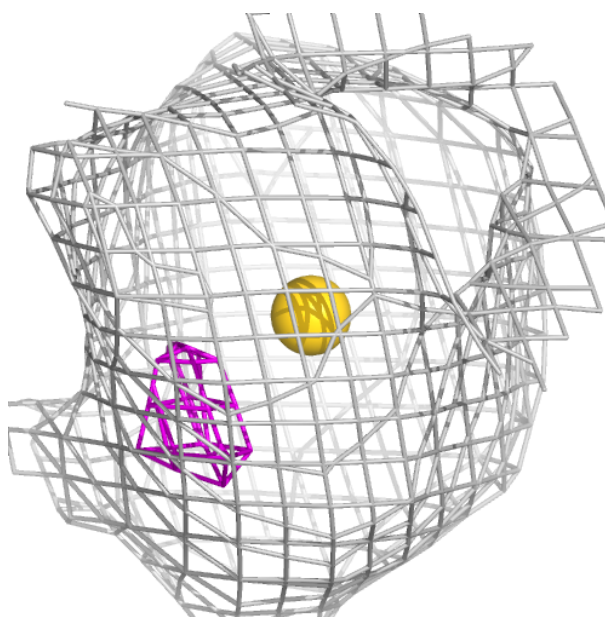

Electron density around AU B 304:

$2mF_o-DF_c$ (at 0.7 rmsd) in gray
 mF_o-DF_c (at 3 rmsd) in purple (negative)
and green (positive)

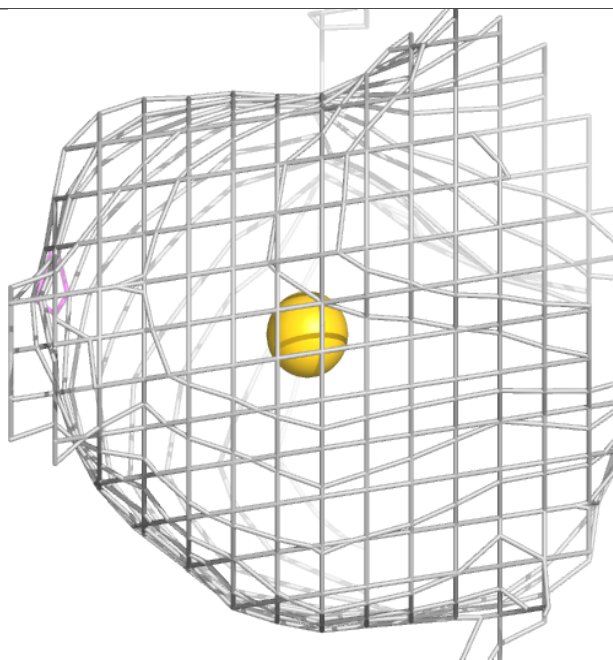
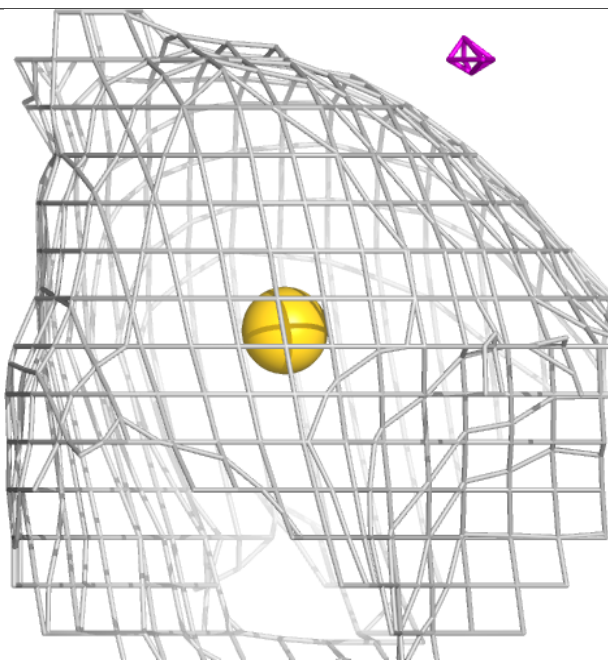
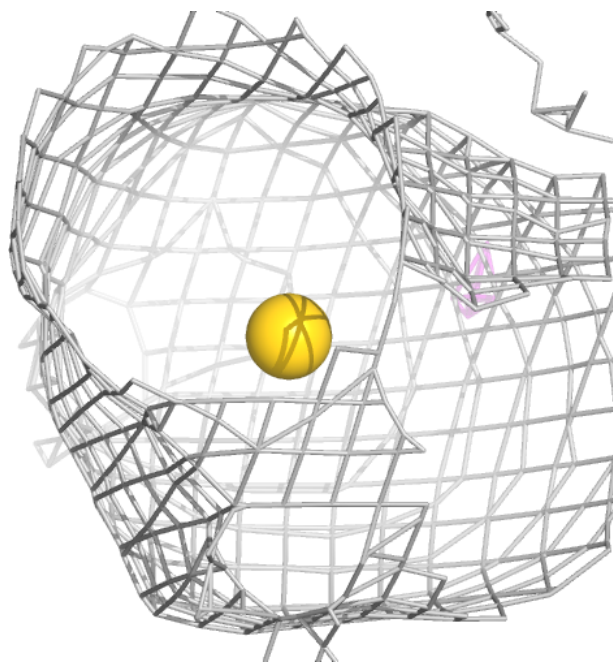

Electron density around AU B 306:

$2mF_o-DF_c$ (at 0.7 rmsd) in gray
 mF_o-DF_c (at 3 rmsd) in purple (negative)
and green (positive)

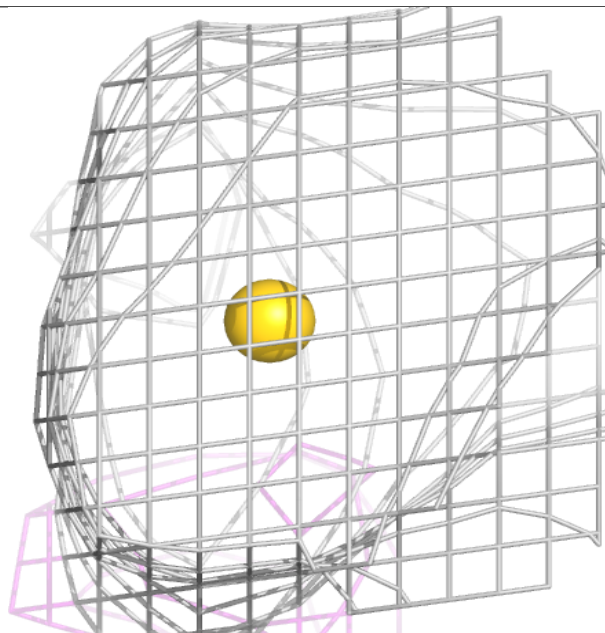
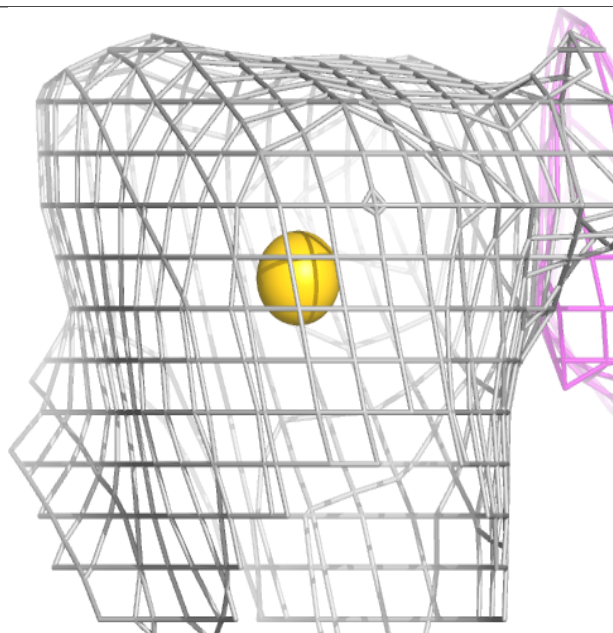
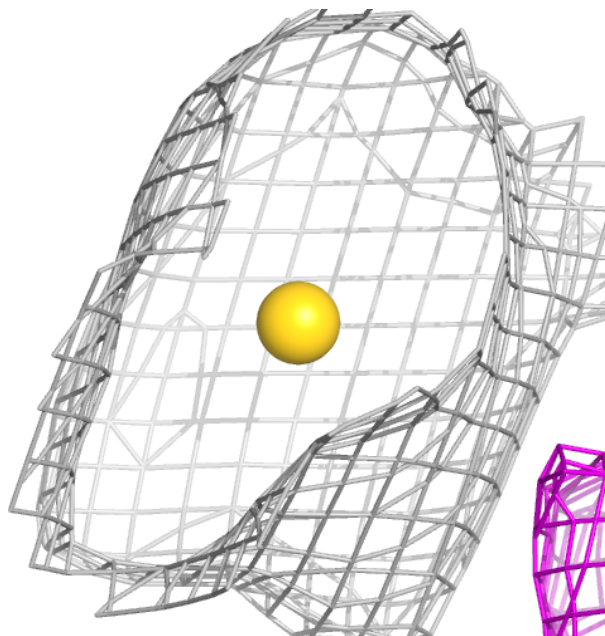

Electron density around AU C 305:

$2mF_o-DF_c$ (at 0.7 rmsd) in gray
 mF_o-DF_c (at 3 rmsd) in purple (negative)
and green (positive)

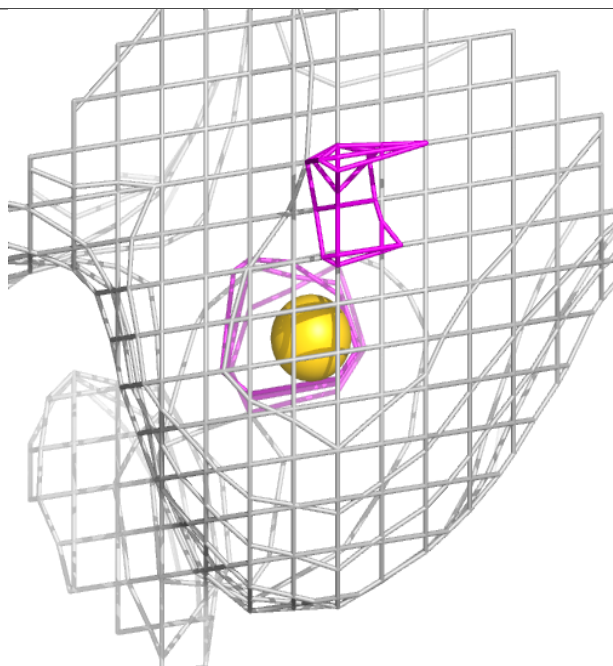
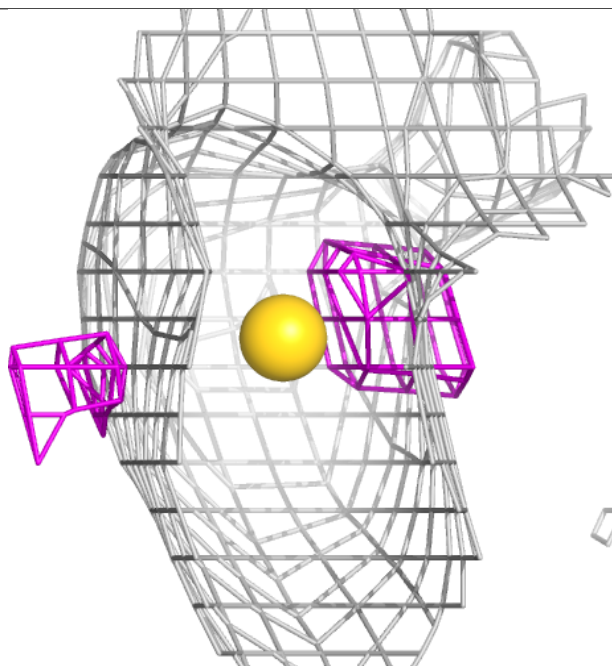

Electron density around AU D 303:

$2mF_o-DF_c$ (at 0.7 rmsd) in gray
 mF_o-DF_c (at 3 rmsd) in purple (negative)
and green (positive)

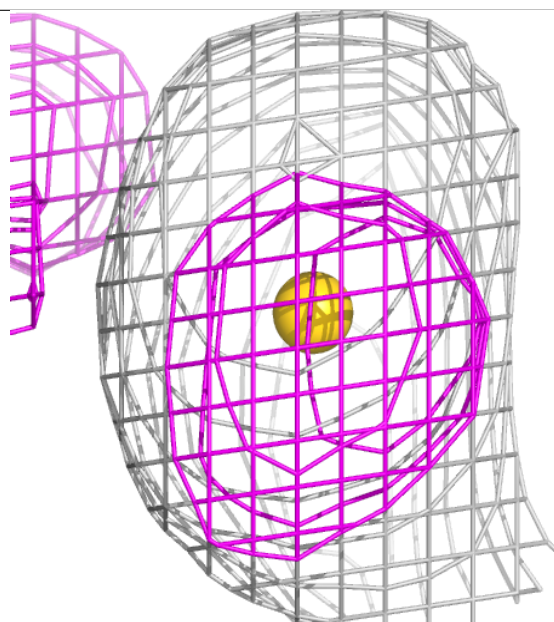
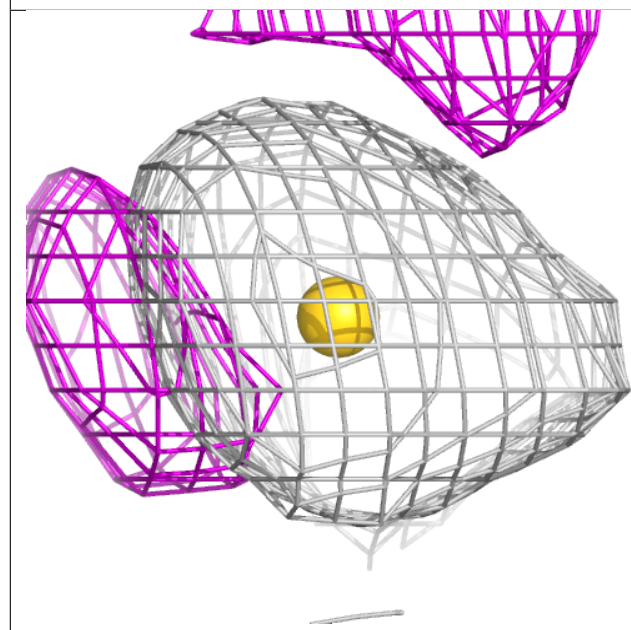
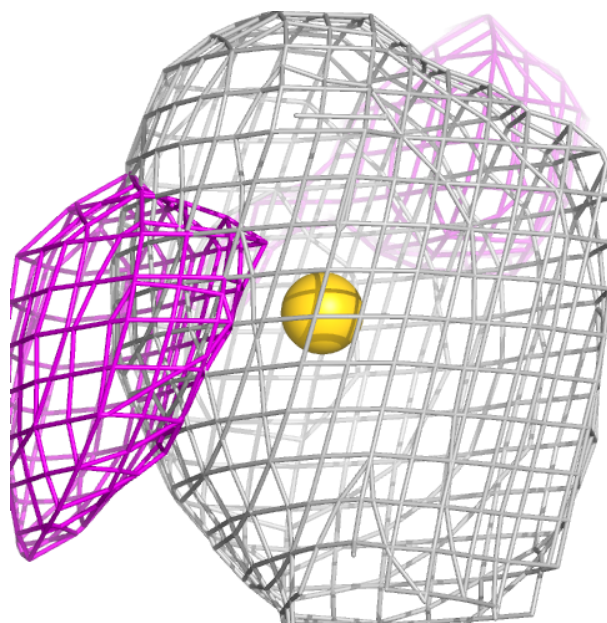

Electron density around CMP A 301:

$2mF_o-DF_c$ (at 0.7 rmsd) in gray
 mF_o-DF_c (at 3 rmsd) in purple (negative)
and green (positive)

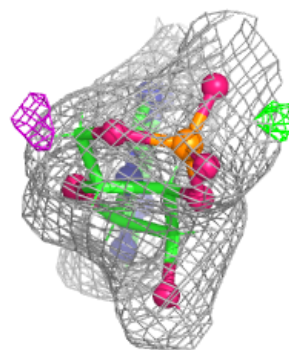
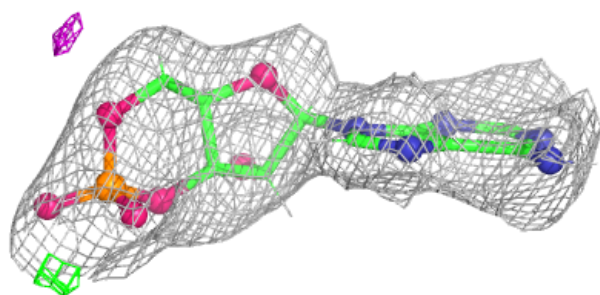
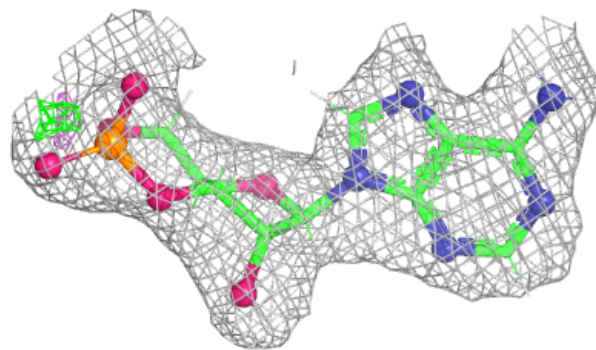

Electron density around AU E 303:

$2mF_o-DF_c$ (at 0.7 rmsd) in gray
 mF_o-DF_c (at 3 rmsd) in purple (negative)
and green (positive)

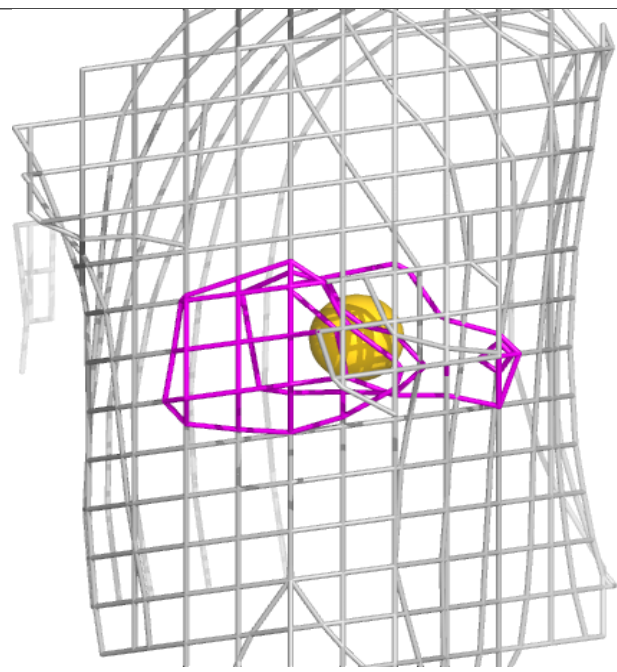
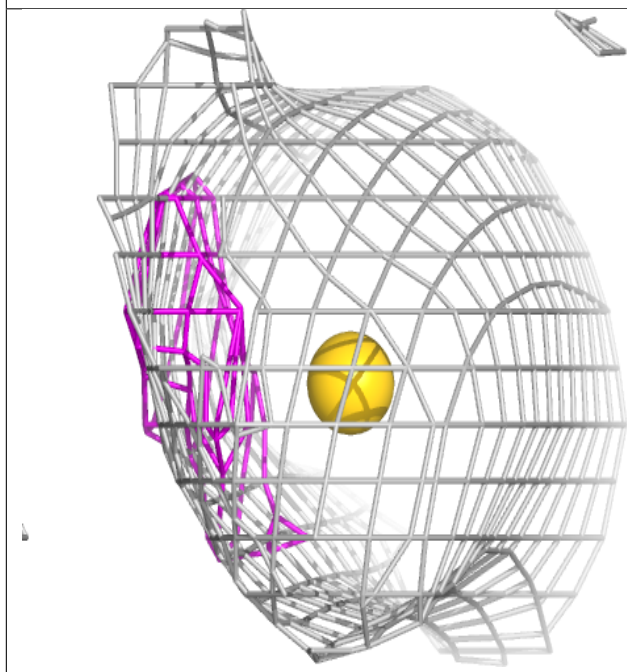
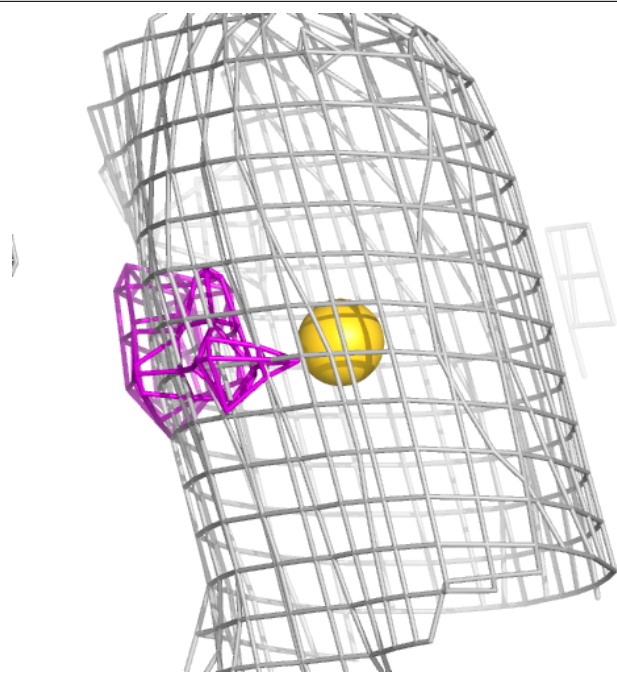

Electron density around AU E 305:

$2mF_o-DF_c$ (at 0.7 rmsd) in gray
 mF_o-DF_c (at 3 rmsd) in purple (negative)
and green (positive)

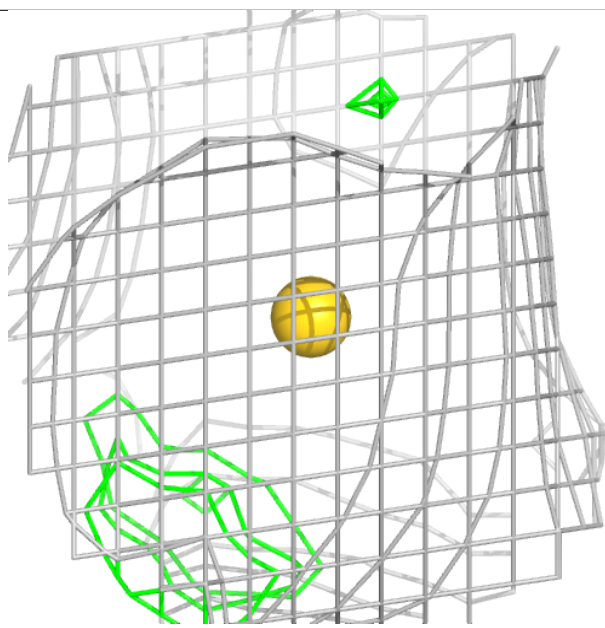
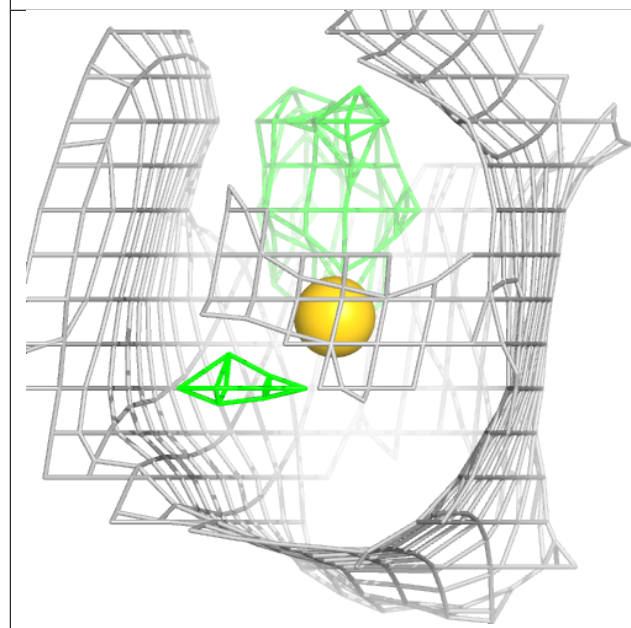
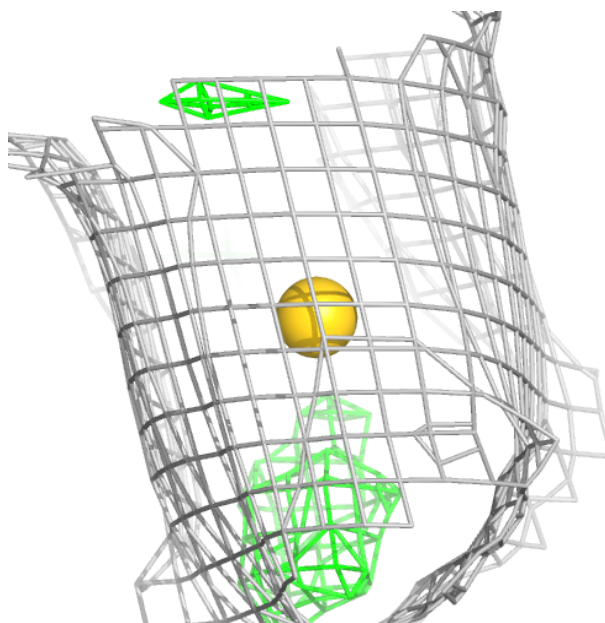

Electron density around CMP B 301:

$2mF_o-DF_c$ (at 0.7 rmsd) in gray
 mF_o-DF_c (at 3 rmsd) in purple (negative)
and green (positive)

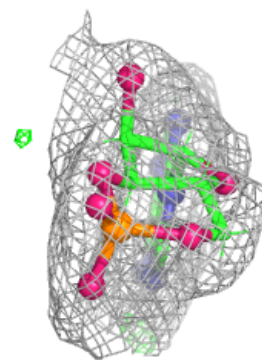
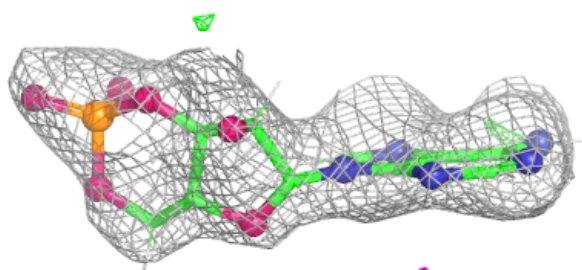
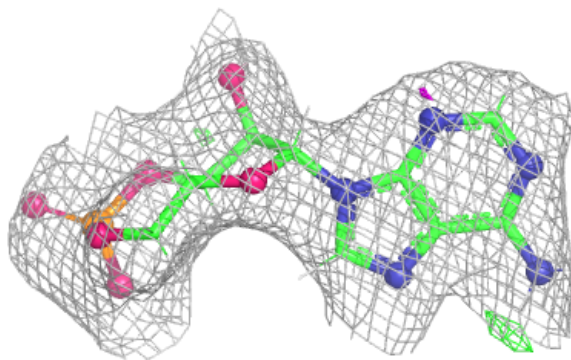

Electron density around AU H 303:

$2mF_o-DF_c$ (at 0.7 rmsd) in gray
 mF_o-DF_c (at 3 rmsd) in purple (negative)
and green (positive)

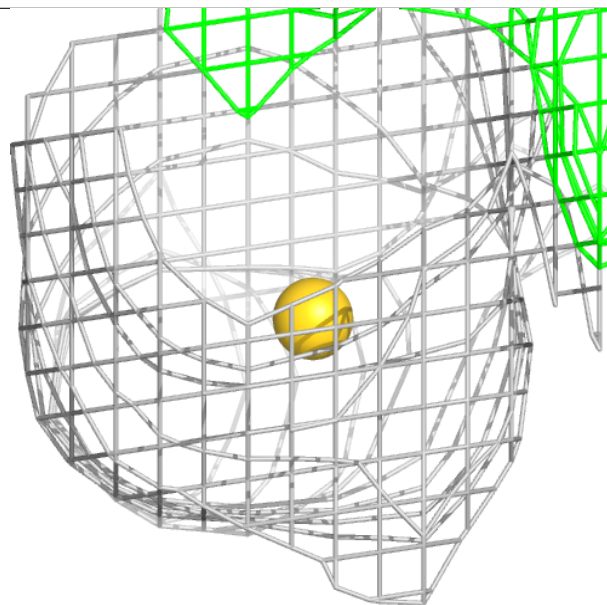
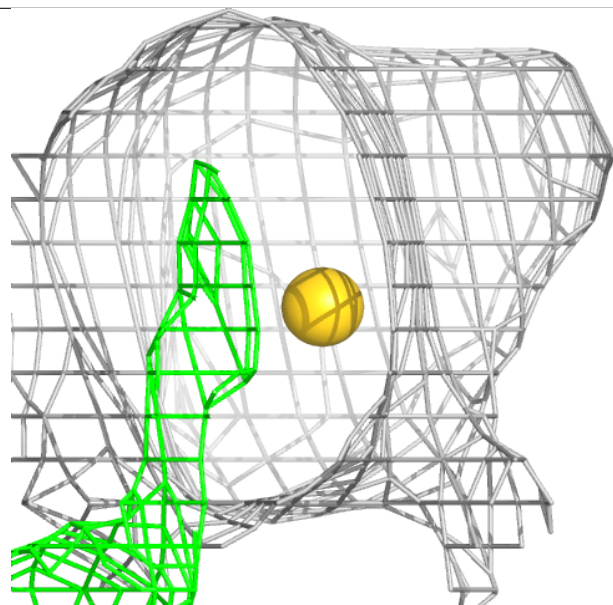
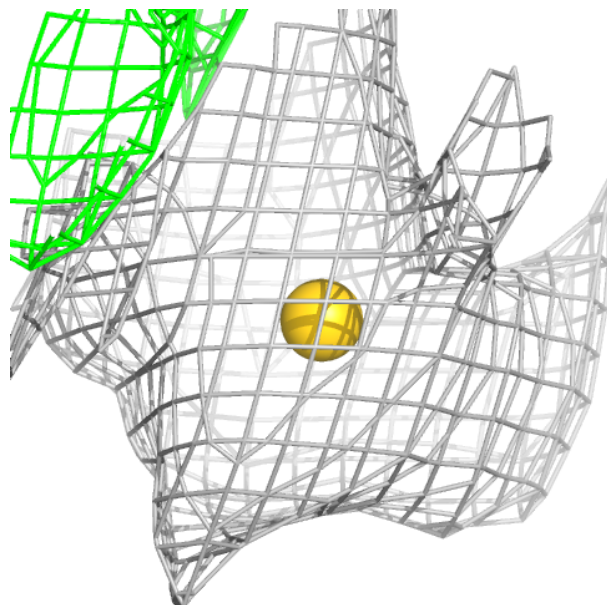

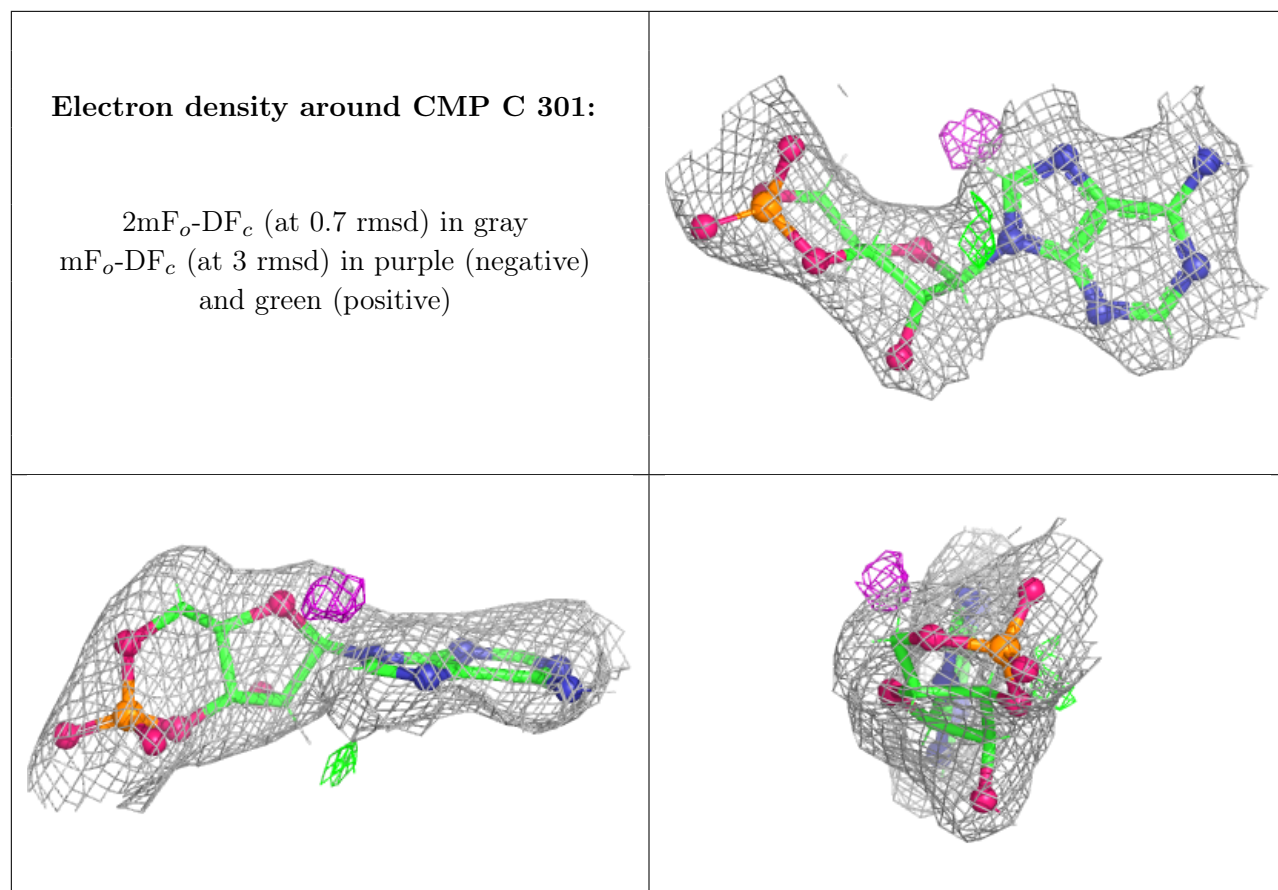

Electron density around CL C 308:

$2mF_o-DF_c$ (at 0.7 rmsd) in gray
 mF_o-DF_c (at 3 rmsd) in purple (negative)
and green (positive)

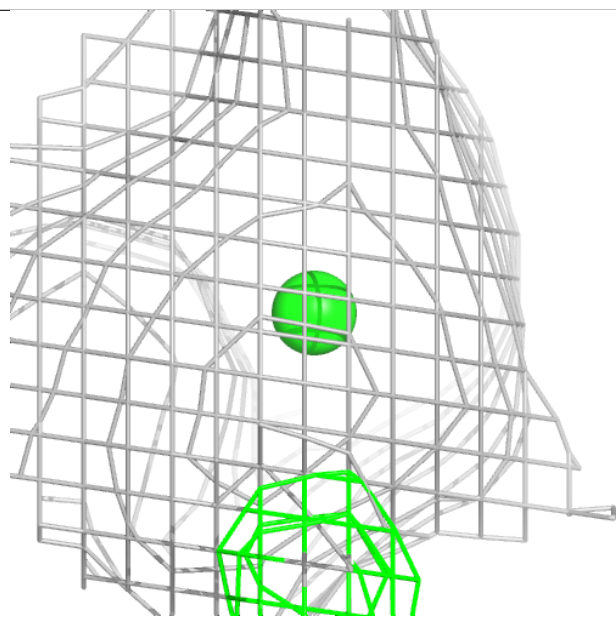
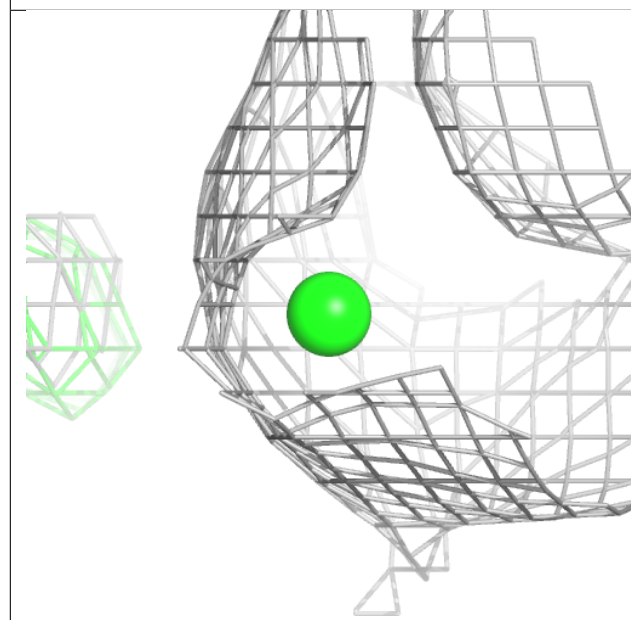
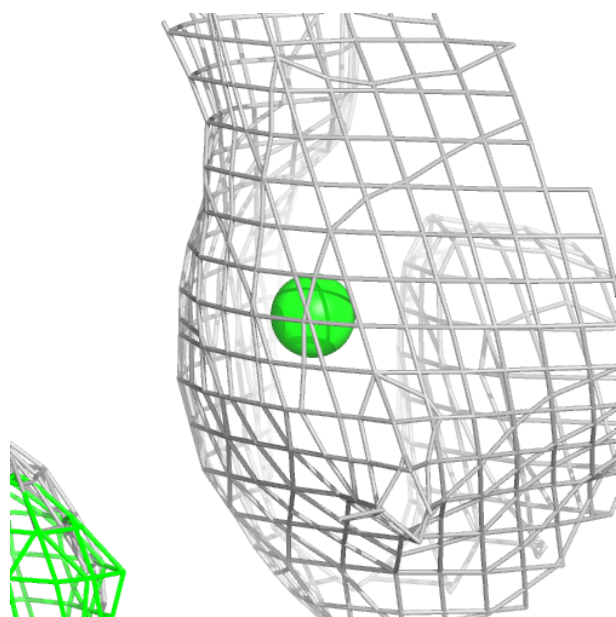

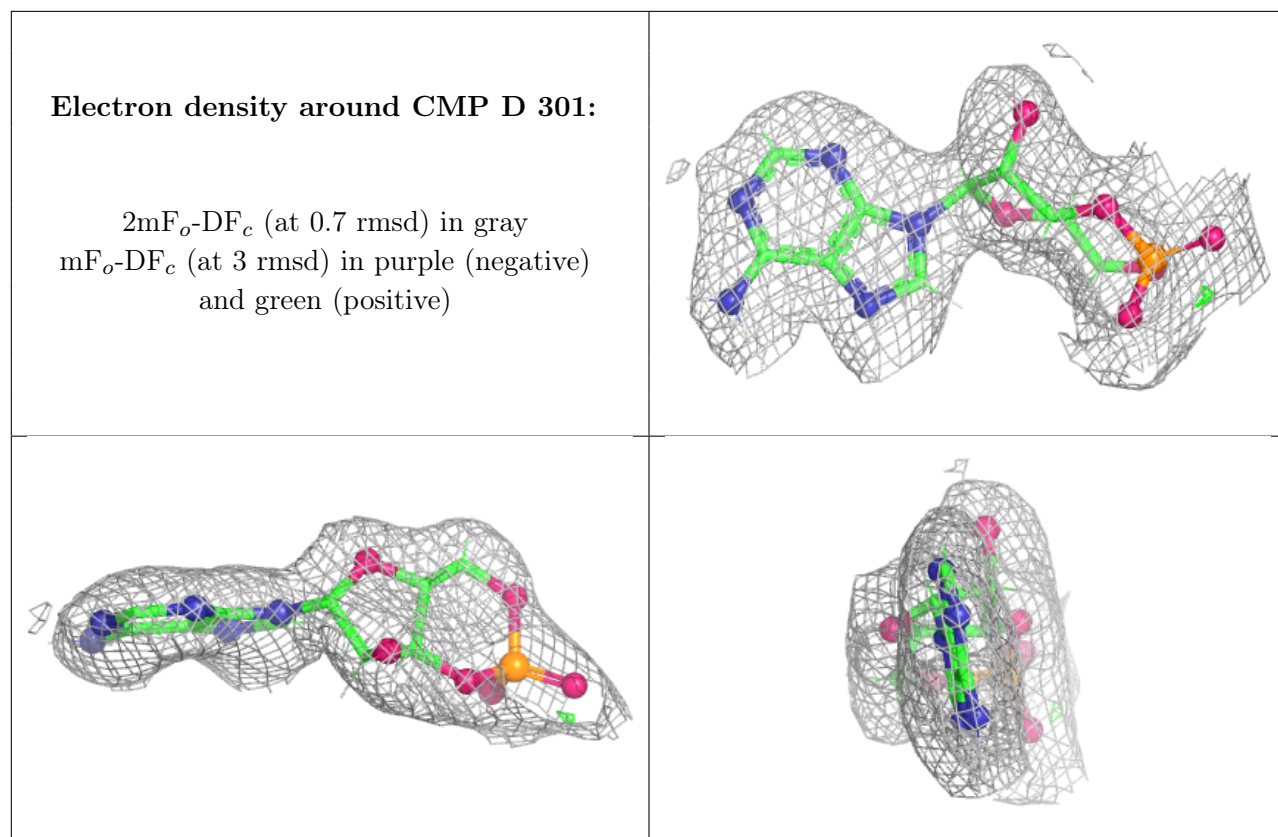

Electron density around CL D 307:

$2mF_o-DF_c$ (at 0.7 rmsd) in gray
 mF_o-DF_c (at 3 rmsd) in purple (negative)
and green (positive)

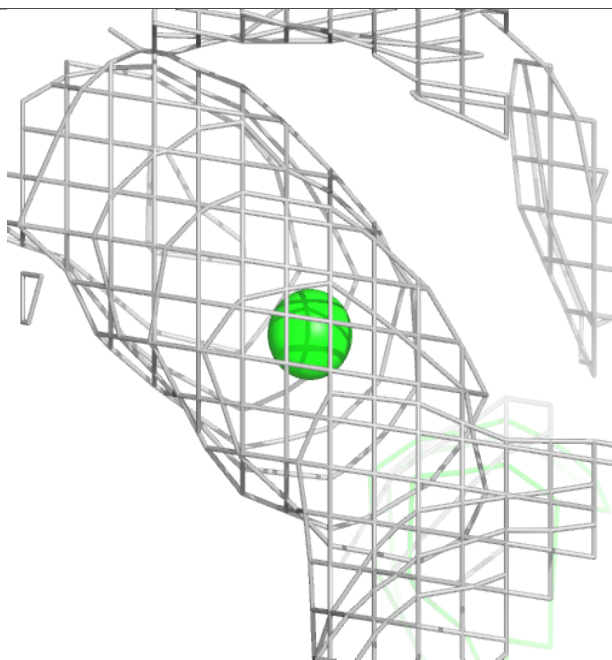
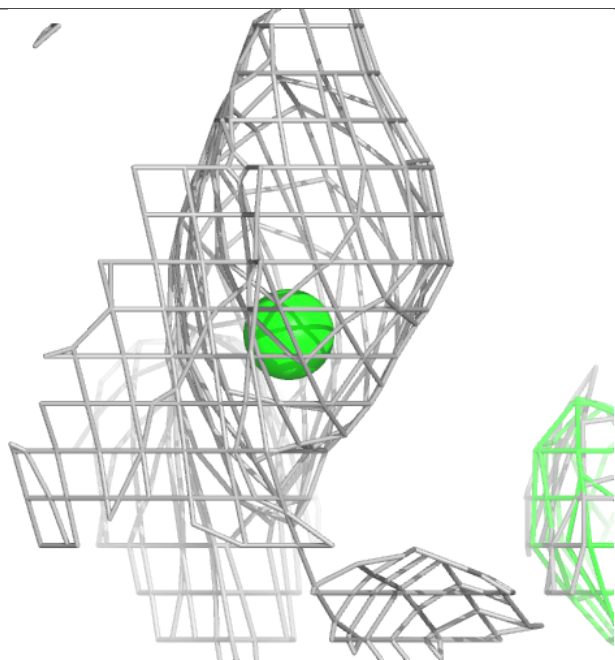
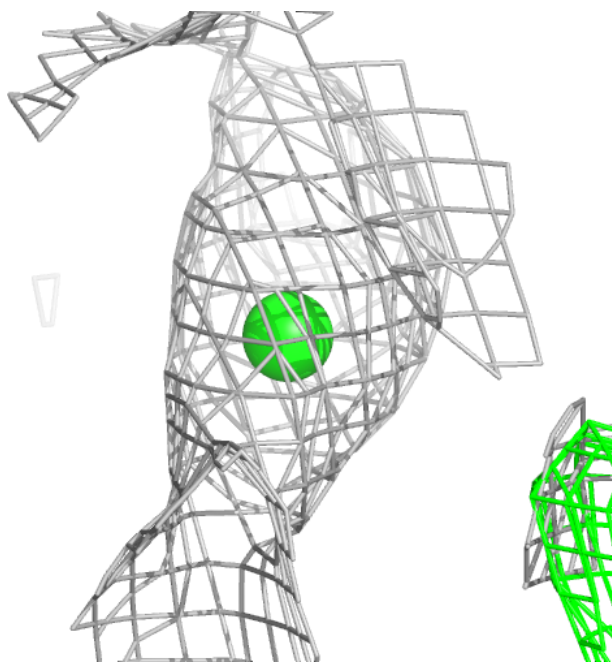

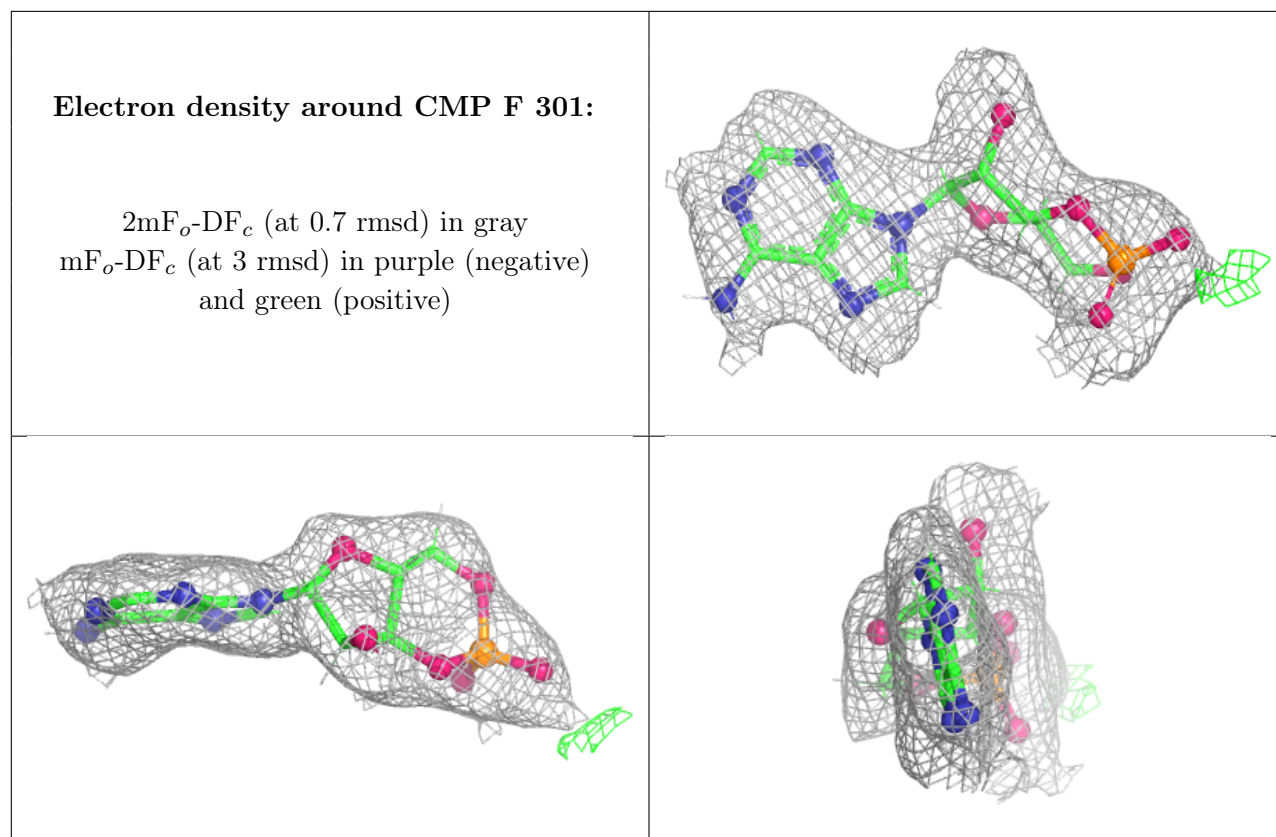

Electron density around CL G 307:

$2mF_o-DF_c$ (at 0.7 rmsd) in gray
 mF_o-DF_c (at 3 rmsd) in purple (negative)
and green (positive)

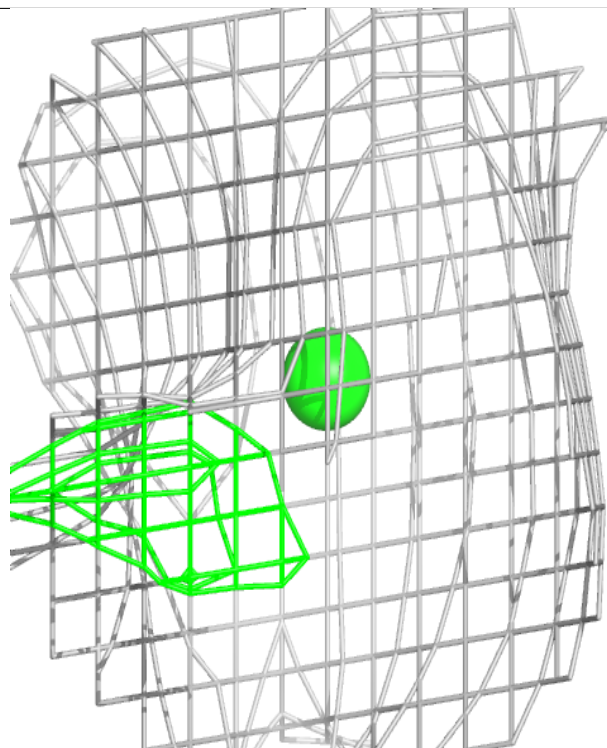
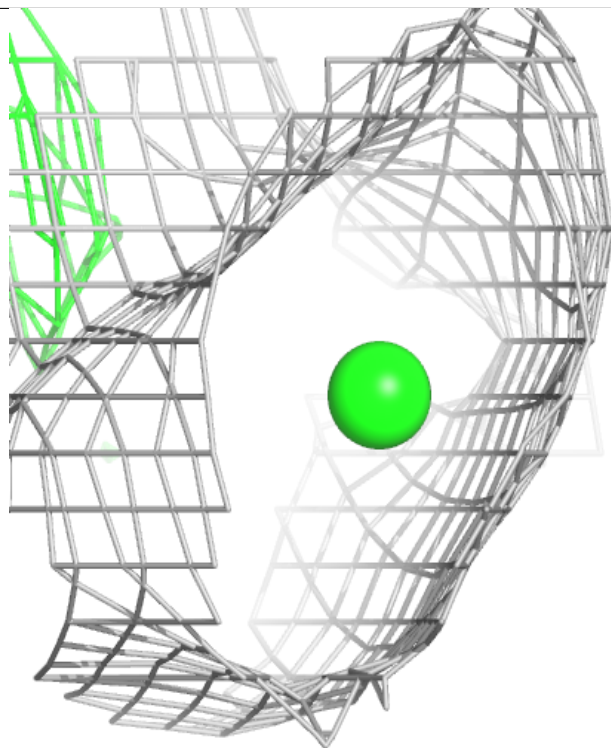
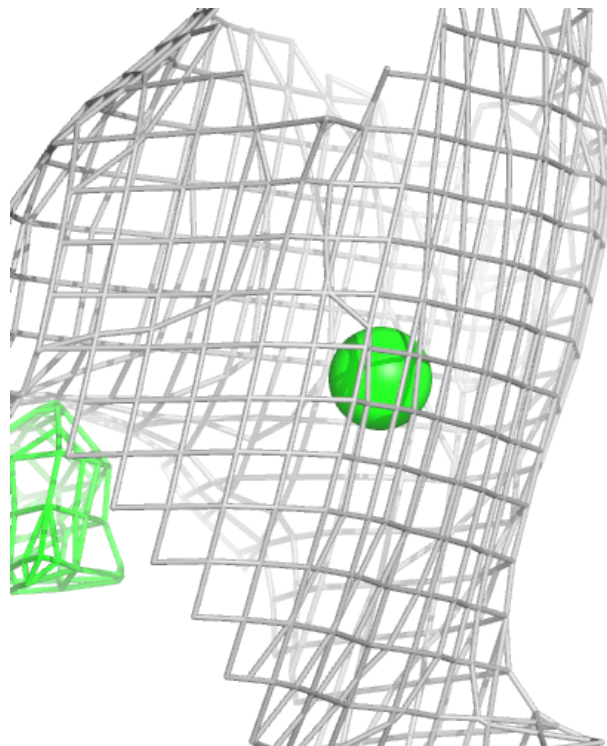

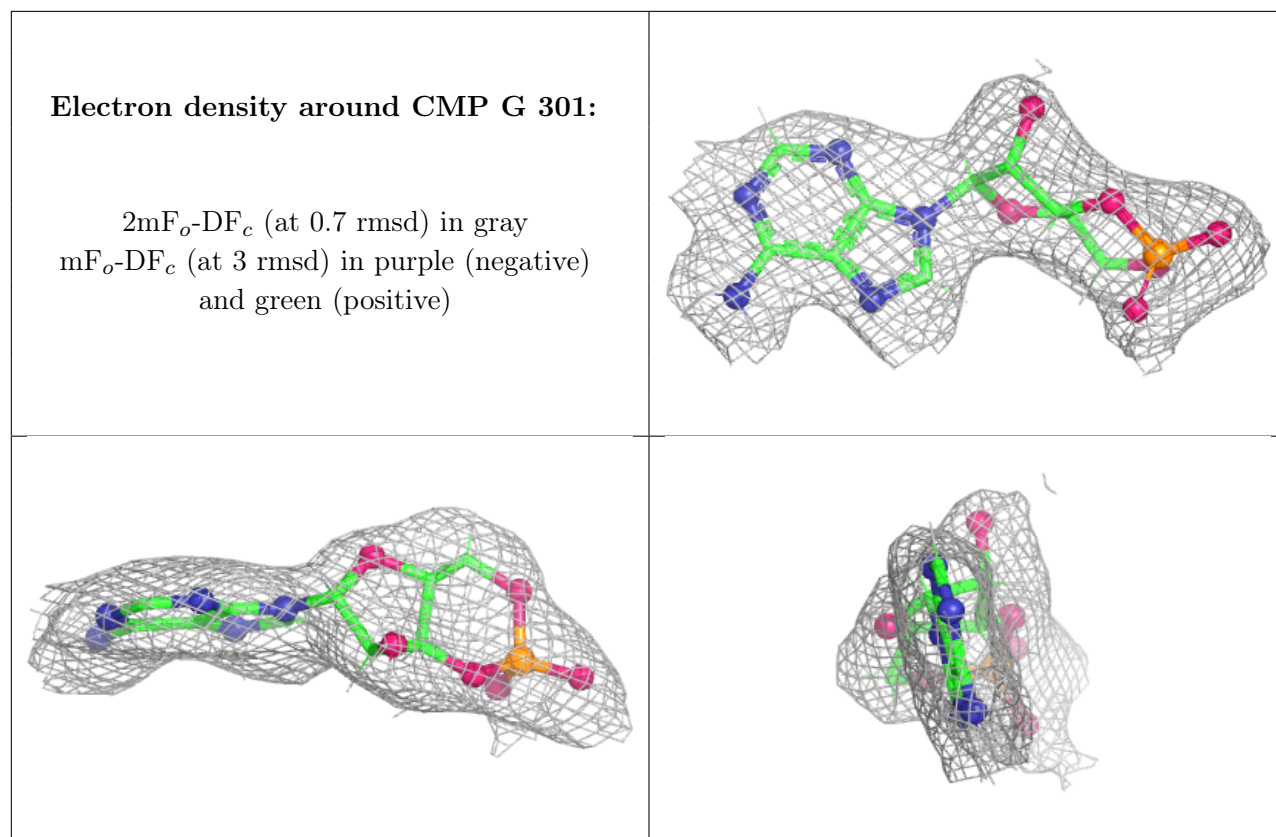

Electron density around AU E 304:

$2mF_o-DF_c$ (at 0.7 rmsd) in gray
 mF_o-DF_c (at 3 rmsd) in purple (negative)
and green (positive)

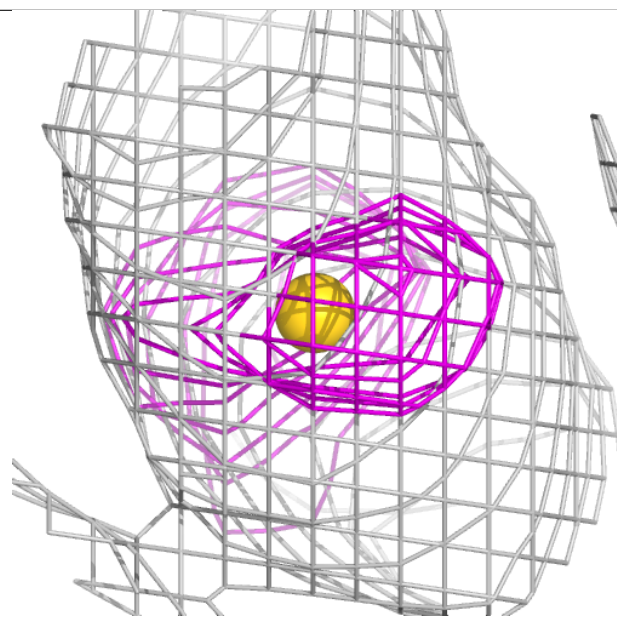
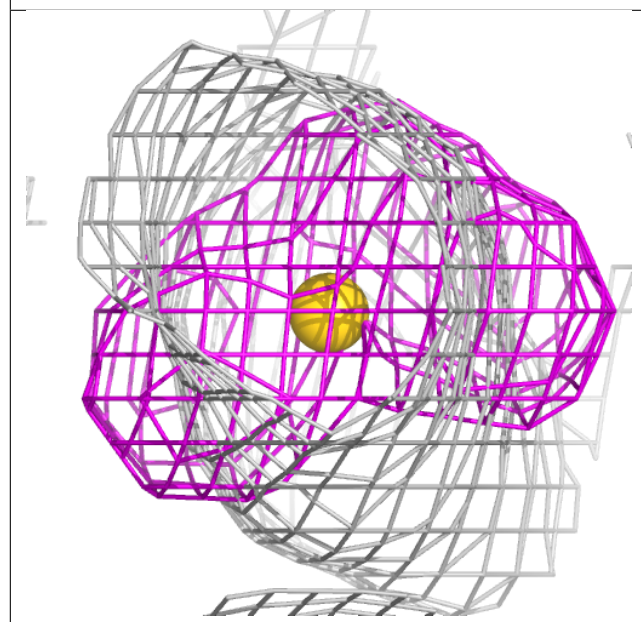
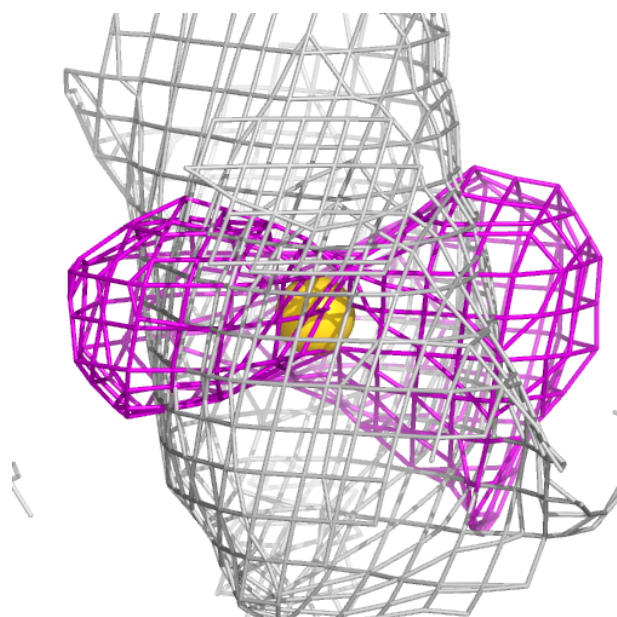

Electron density around AU A 302:

$2mF_o-DF_c$ (at 0.7 rmsd) in gray
 mF_o-DF_c (at 3 rmsd) in purple (negative)
and green (positive)

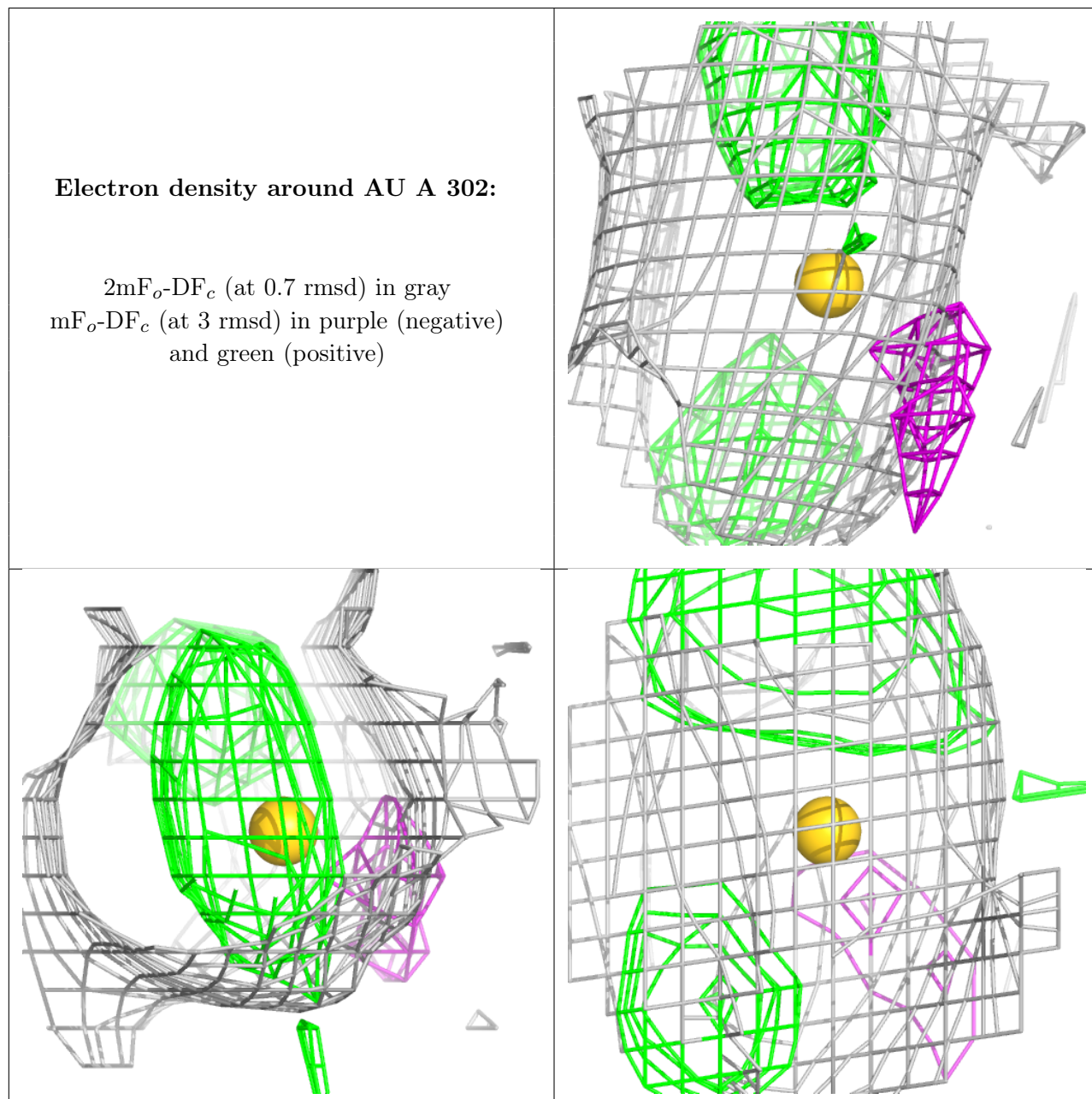

Electron density around AU E 306:

$2mF_o-DF_c$ (at 0.7 rmsd) in gray
 mF_o-DF_c (at 3 rmsd) in purple (negative)
and green (positive)

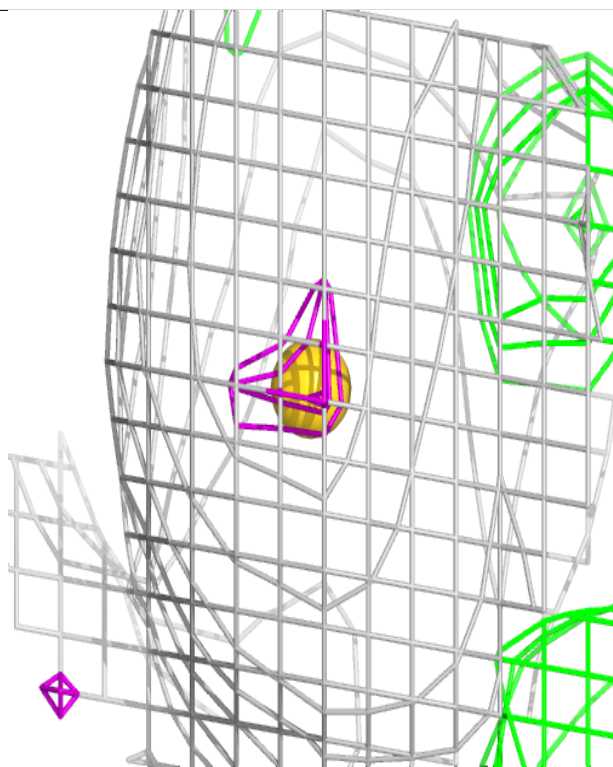
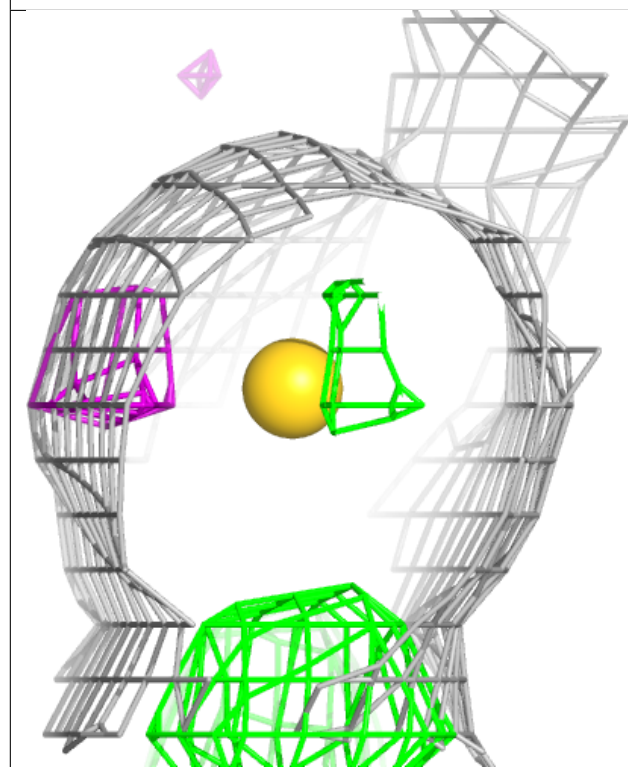
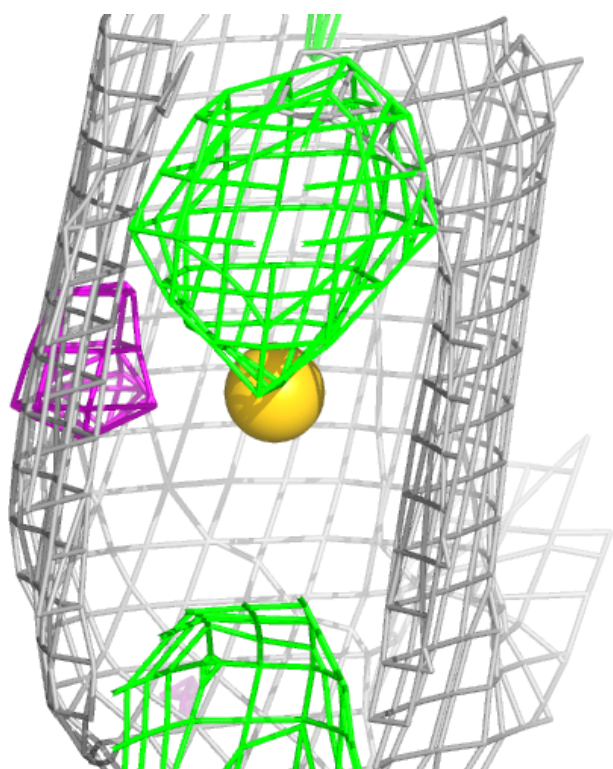

Electron density around AU F 302:

$2mF_o-DF_c$ (at 0.7 rmsd) in gray
 mF_o-DF_c (at 3 rmsd) in purple (negative)
and green (positive)

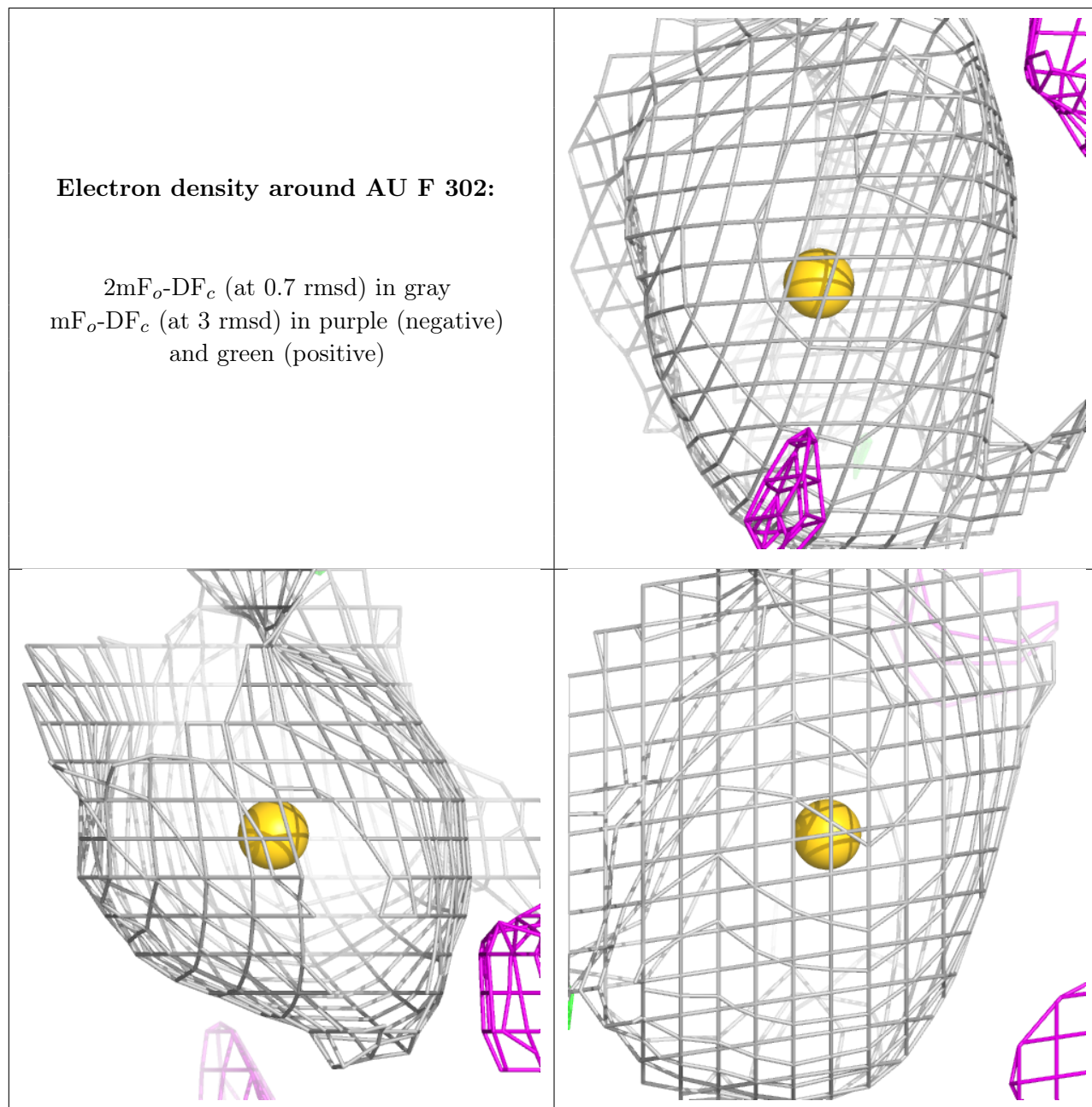

Electron density around AU F 303:

$2mF_o-DF_c$ (at 0.7 rmsd) in gray
 mF_o-DF_c (at 3 rmsd) in purple (negative)
and green (positive)

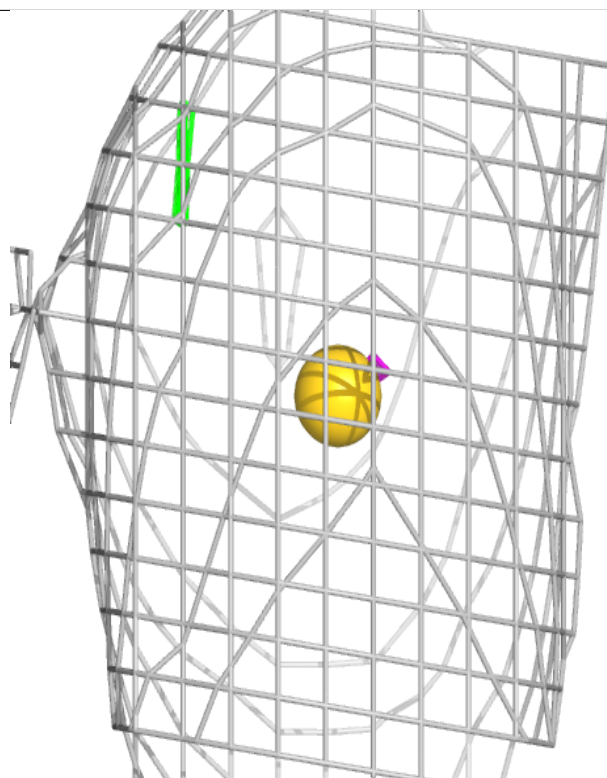
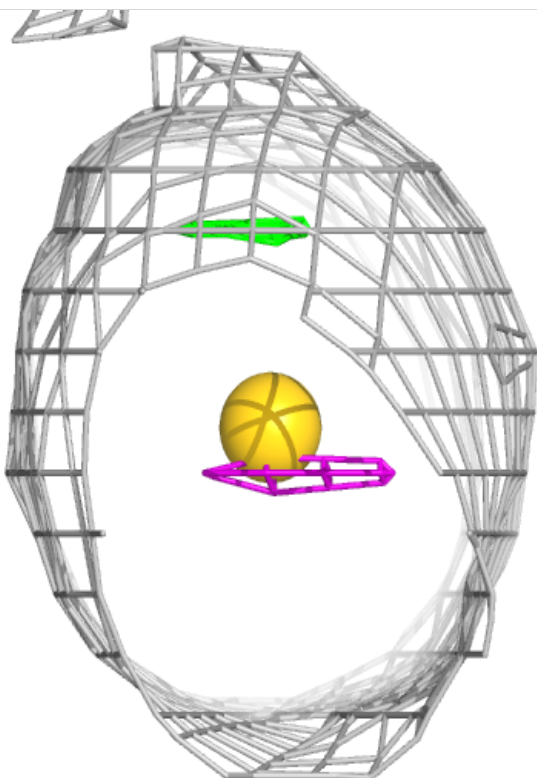
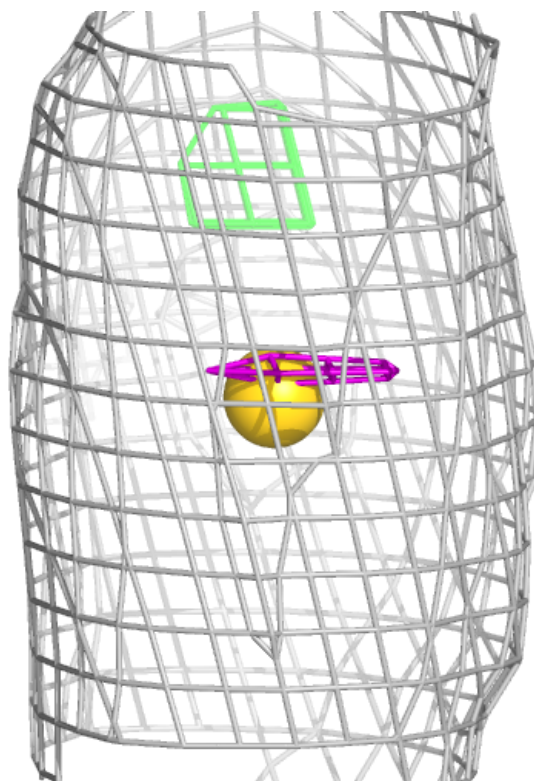

Electron density around AU B 305:

$2mF_o-DF_c$ (at 0.7 rmsd) in gray
 mF_o-DF_c (at 3 rmsd) in purple (negative)
and green (positive)

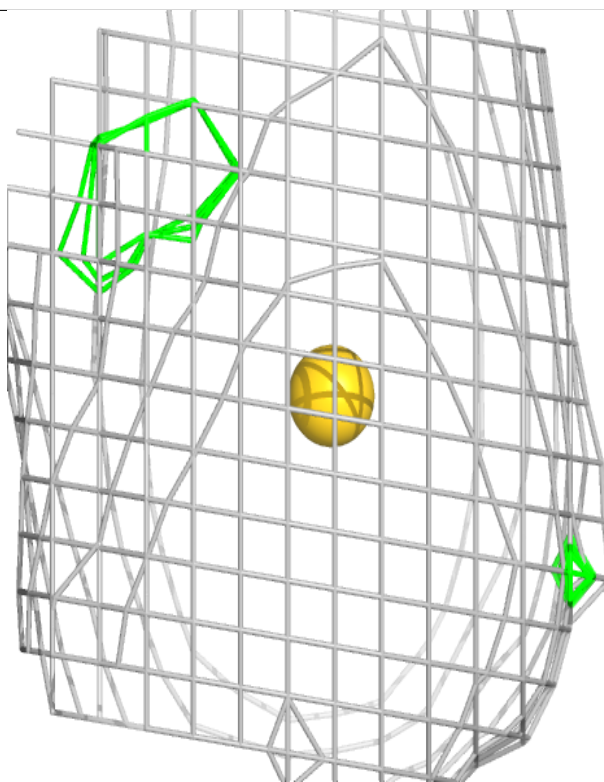
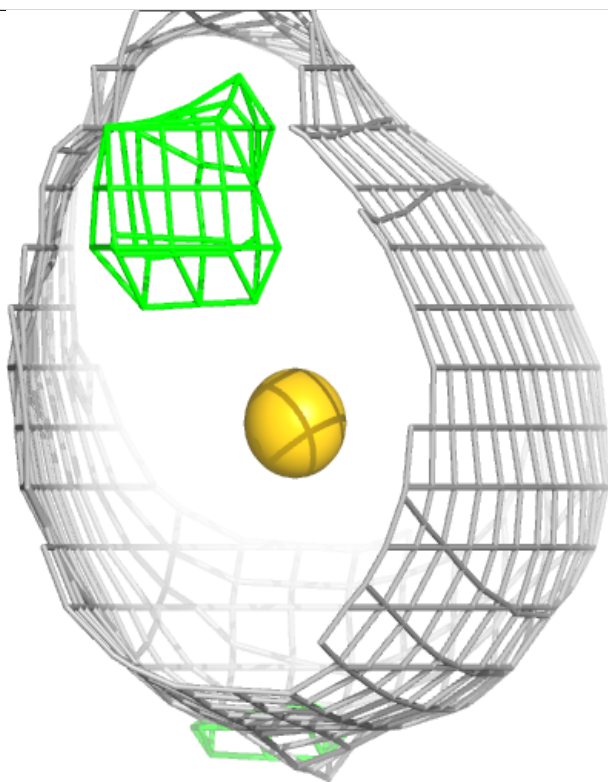
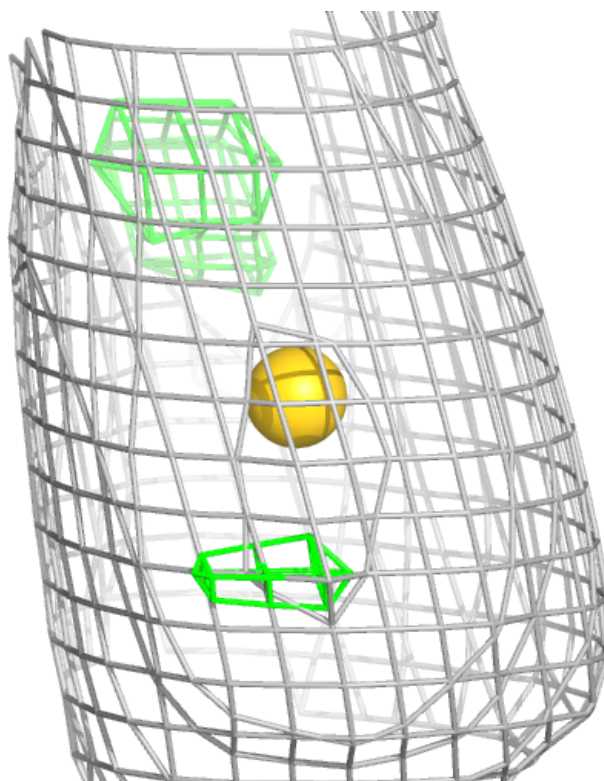

Electron density around AU G 303:

$2mF_o-DF_c$ (at 0.7 rmsd) in gray
 mF_o-DF_c (at 3 rmsd) in purple (negative)
and green (positive)

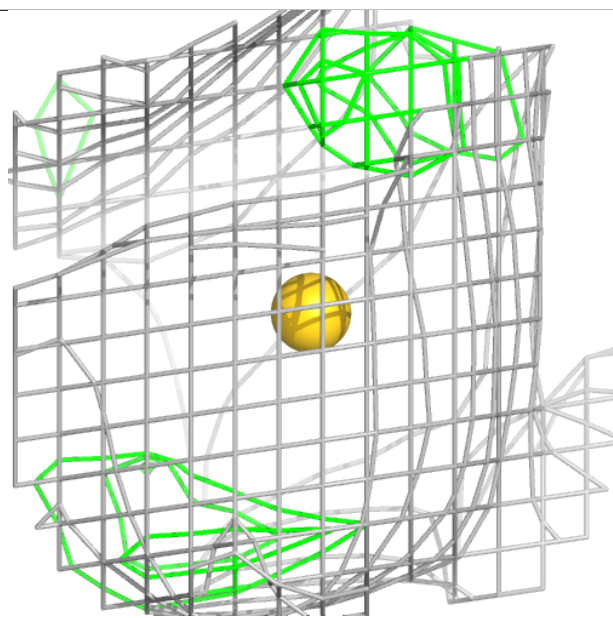
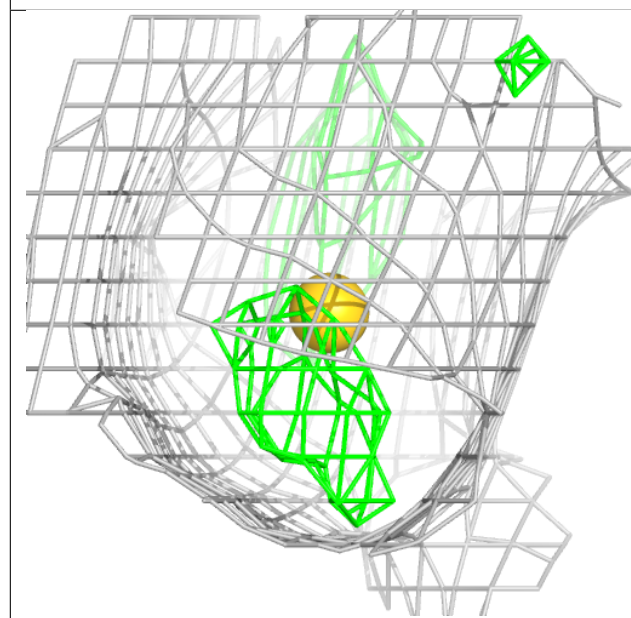
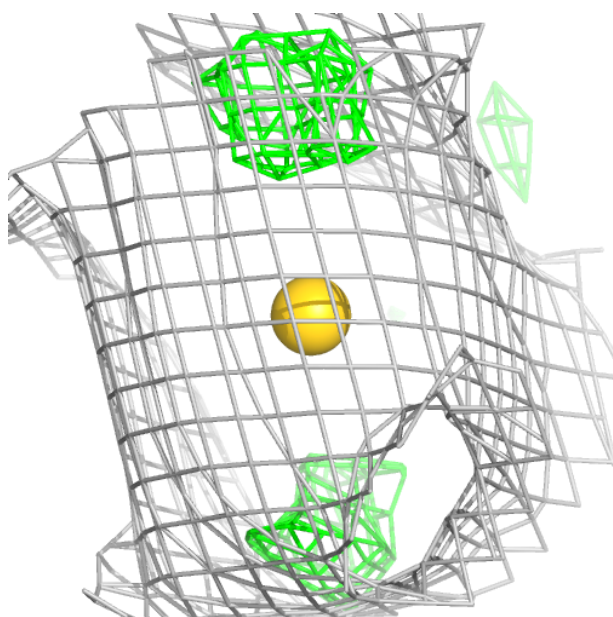

Electron density around AU G 304:

$2mF_o-DF_c$ (at 0.7 rmsd) in gray
 mF_o-DF_c (at 3 rmsd) in purple (negative)
and green (positive)

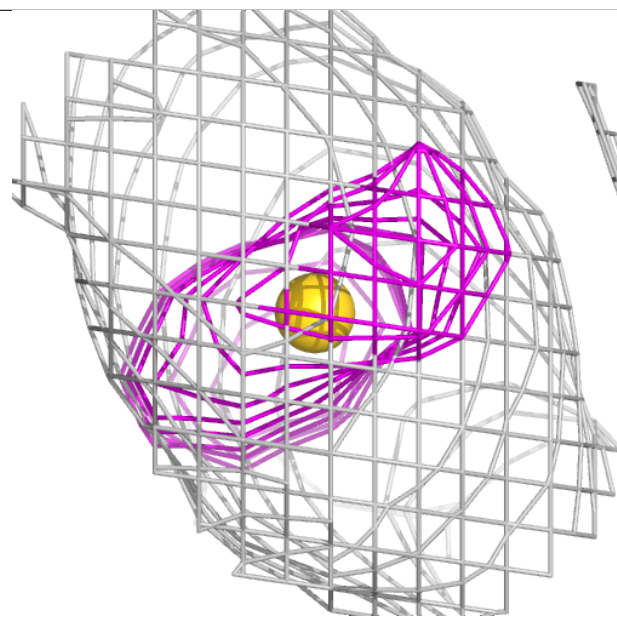
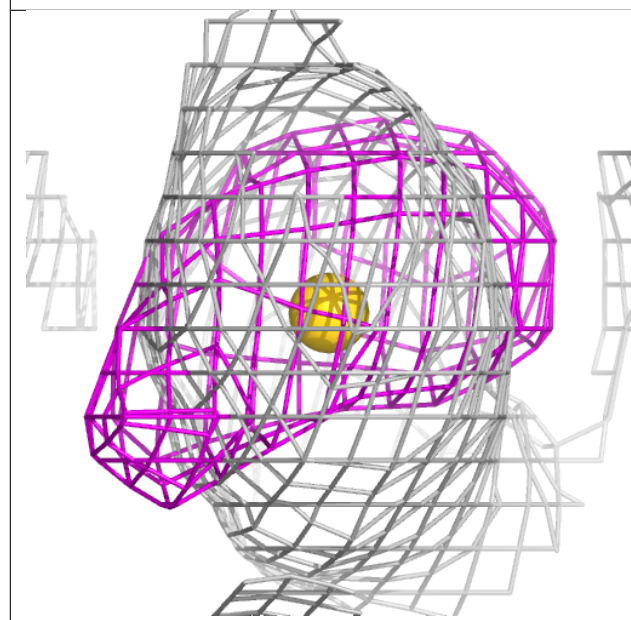
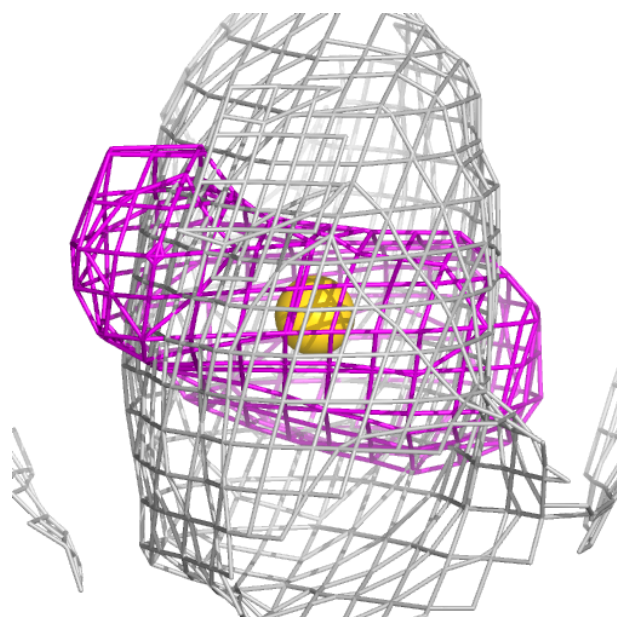

Electron density around AU G 305:

$2mF_o-DF_c$ (at 0.7 rmsd) in gray
 mF_o-DF_c (at 3 rmsd) in purple (negative)
and green (positive)

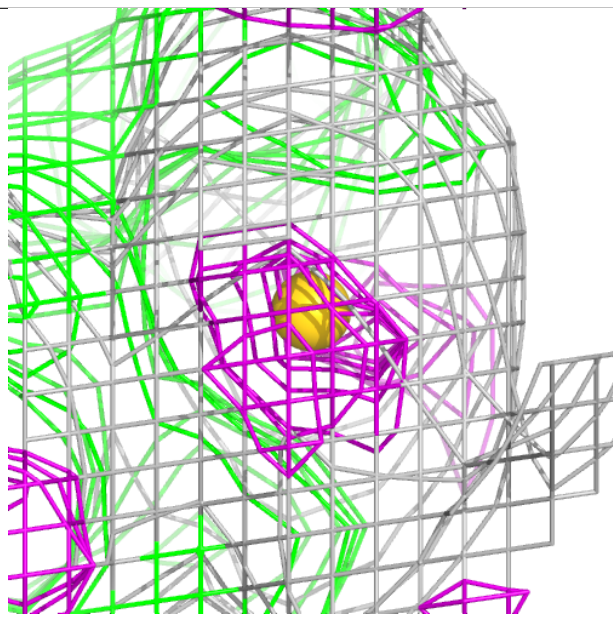
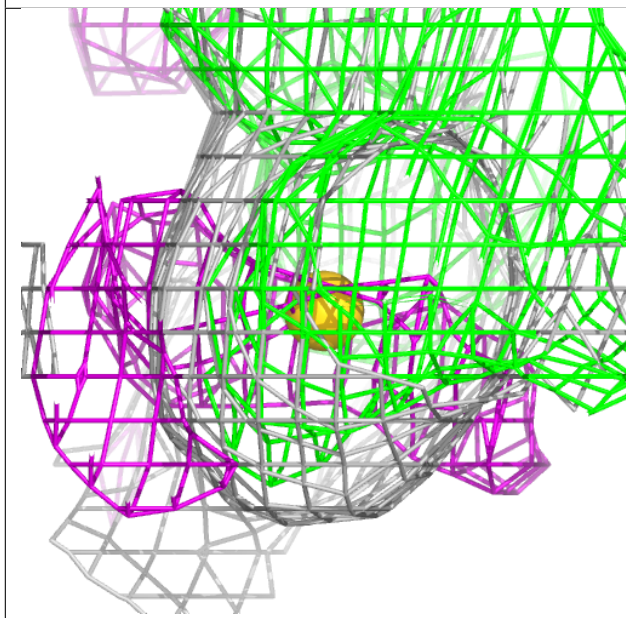
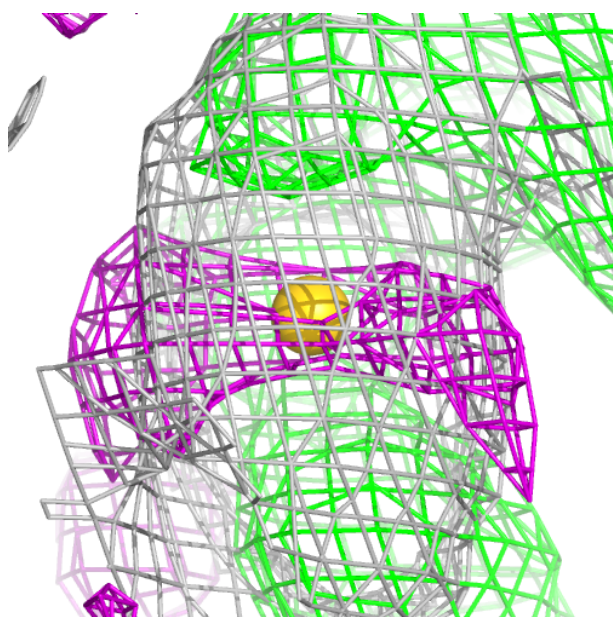

Electron density around AU H 302:

$2mF_o-DF_c$ (at 0.7 rmsd) in gray
 mF_o-DF_c (at 3 rmsd) in purple (negative)
and green (positive)

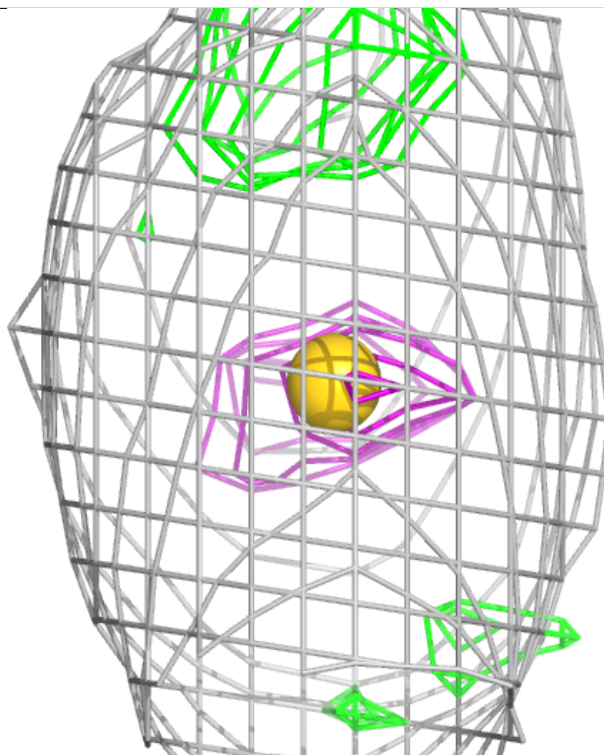
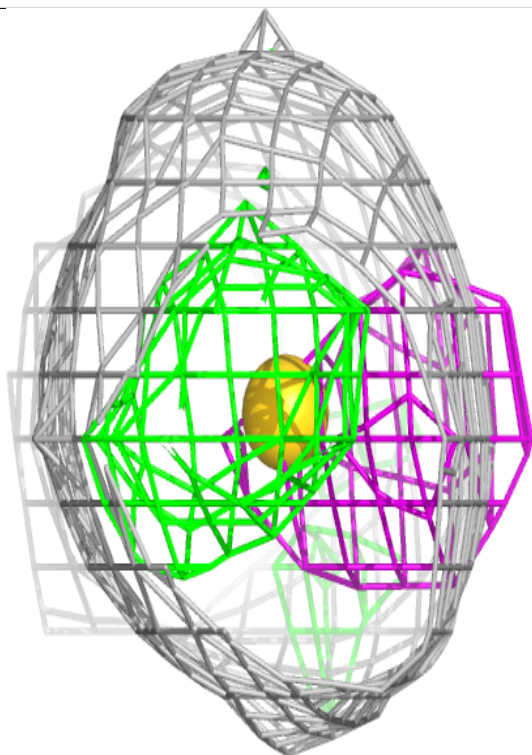
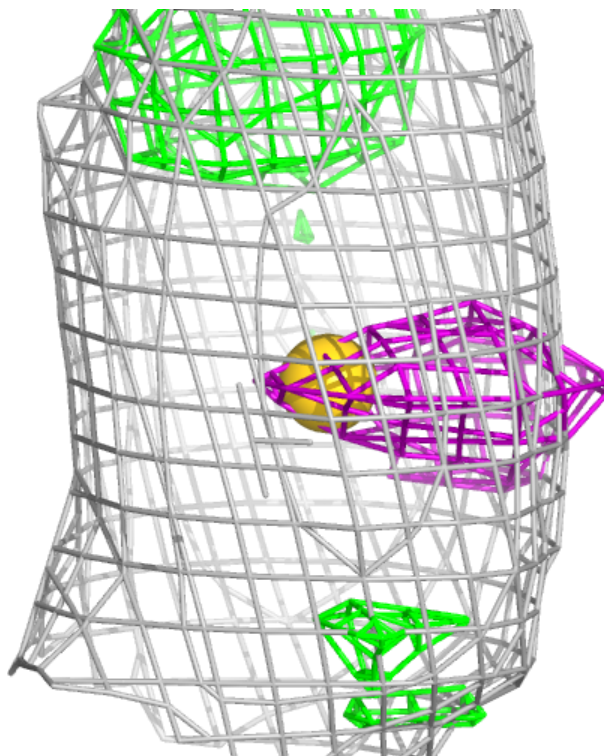

Electron density around AU A 303:

$2mF_o-DF_c$ (at 0.7 rmsd) in gray
 mF_o-DF_c (at 3 rmsd) in purple (negative)
and green (positive)

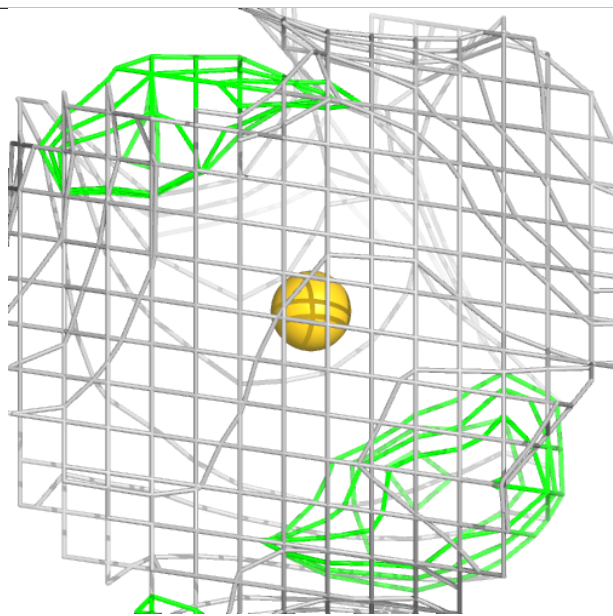
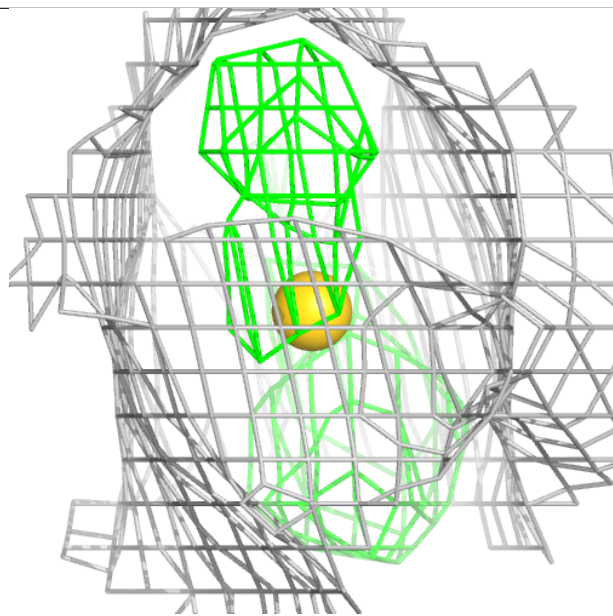
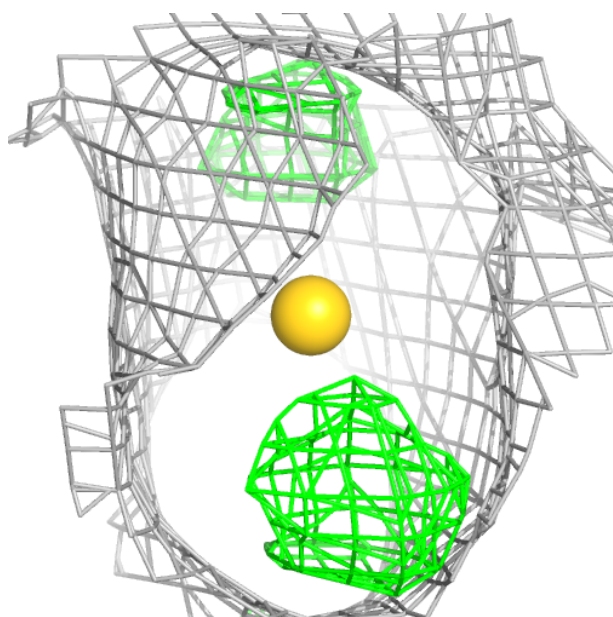

Electron density around AU H 304:

$2mF_o-DF_c$ (at 0.7 rmsd) in gray
 mF_o-DF_c (at 3 rmsd) in purple (negative)
and green (positive)

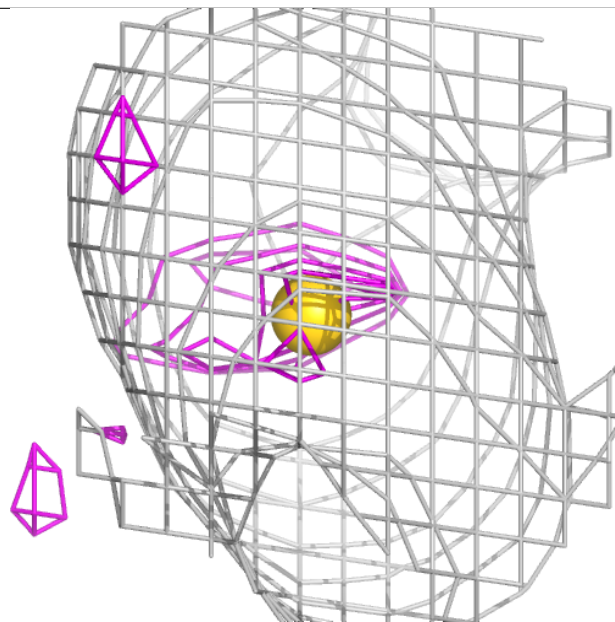
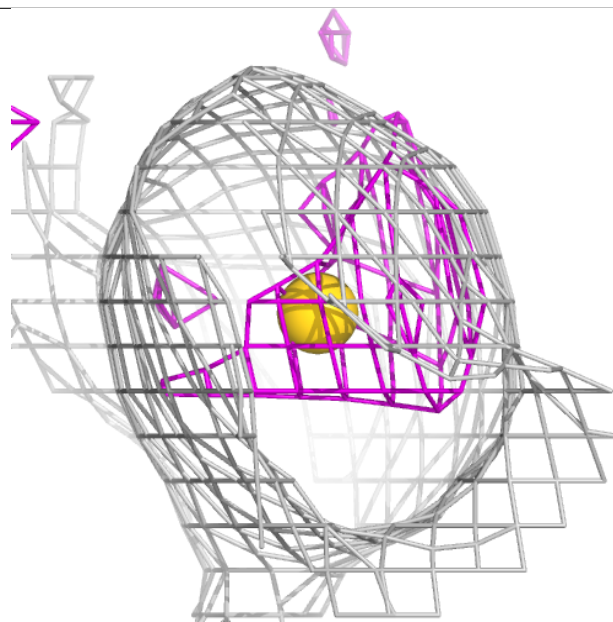
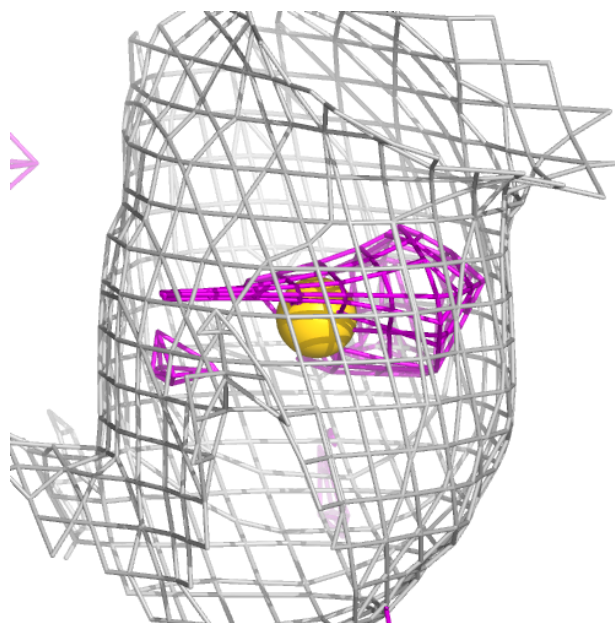

Electron density around CL A 306:

$2mF_o-DF_c$ (at 0.7 rmsd) in gray
 mF_o-DF_c (at 3 rmsd) in purple (negative)
and green (positive)

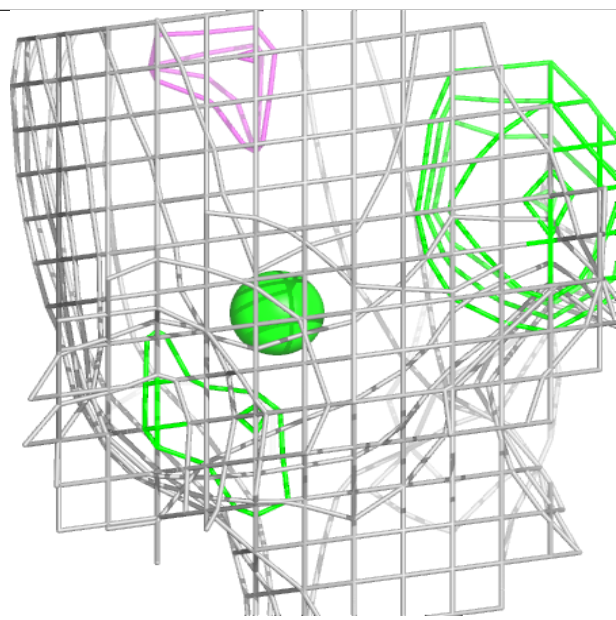
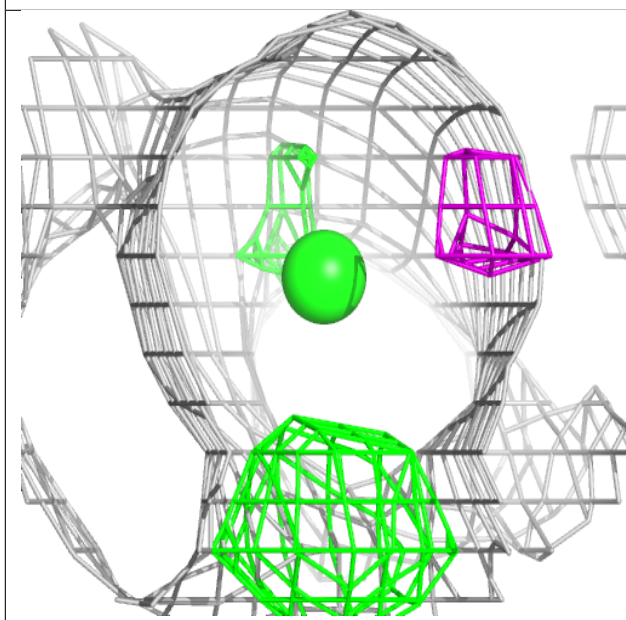
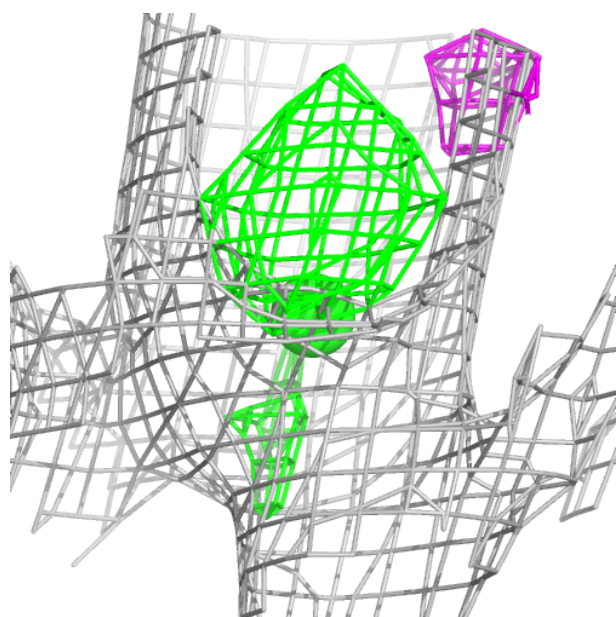

Electron density around CL A 307:

$2mF_o-DF_c$ (at 0.7 rmsd) in gray
 mF_o-DF_c (at 3 rmsd) in purple (negative)
and green (positive)

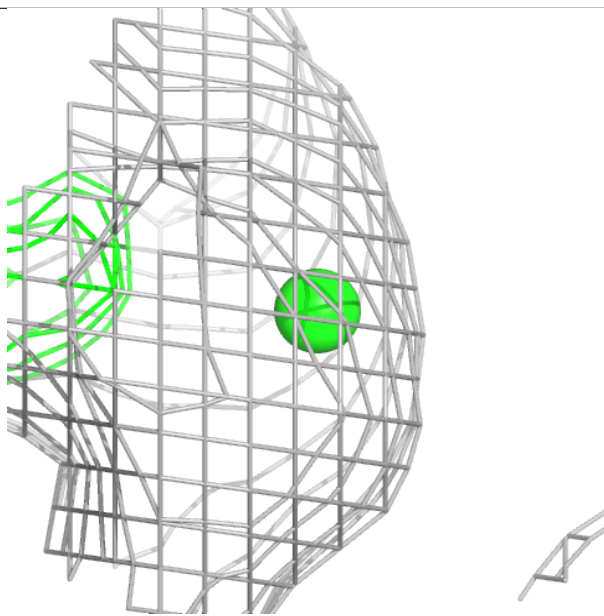
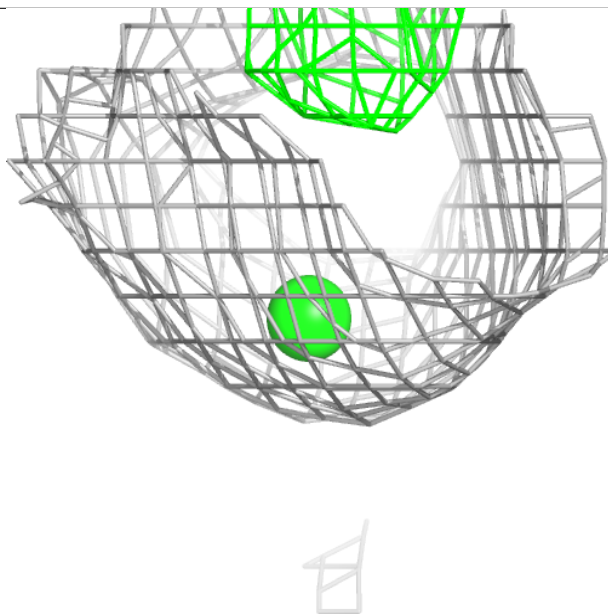
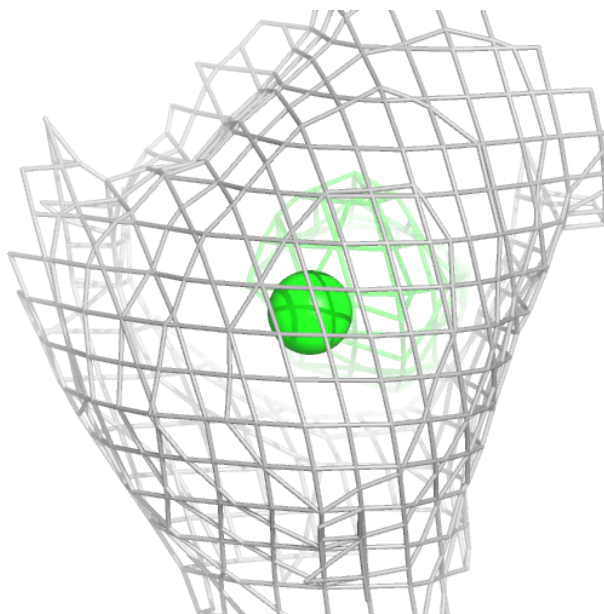

Electron density around AU C 303:

$2mF_o-DF_c$ (at 0.7 rmsd) in gray
 mF_o-DF_c (at 3 rmsd) in purple (negative)
and green (positive)

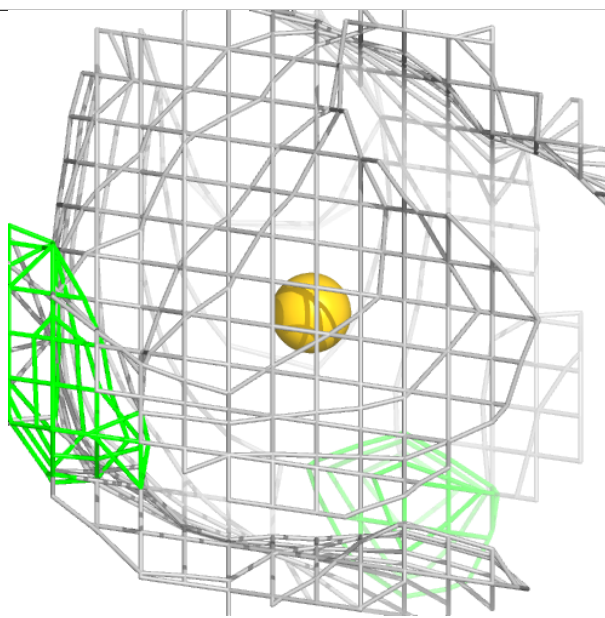
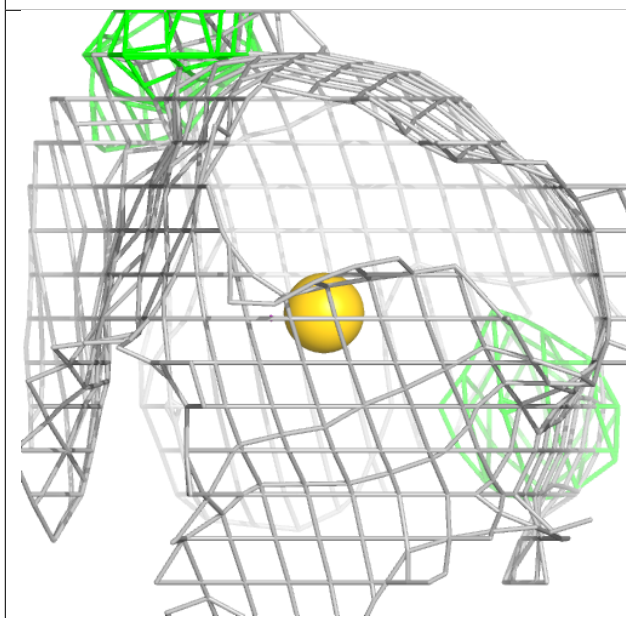
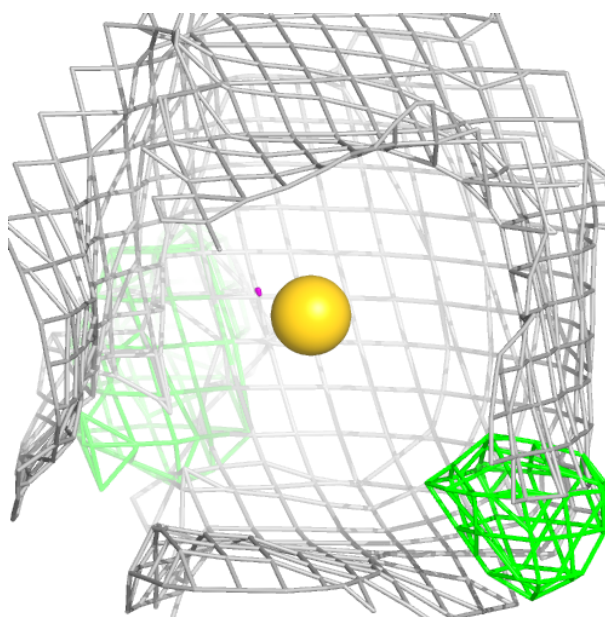

Electron density around CL B 308:

$2mF_o-DF_c$ (at 0.7 rmsd) in gray
 mF_o-DF_c (at 3 rmsd) in purple (negative)
and green (positive)

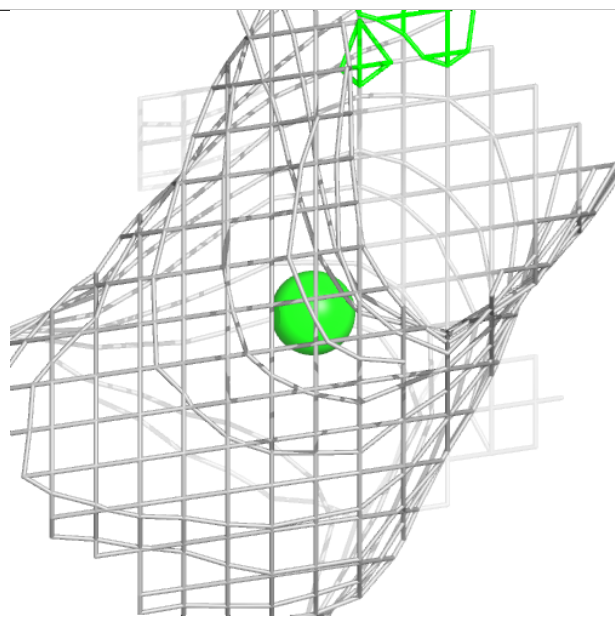
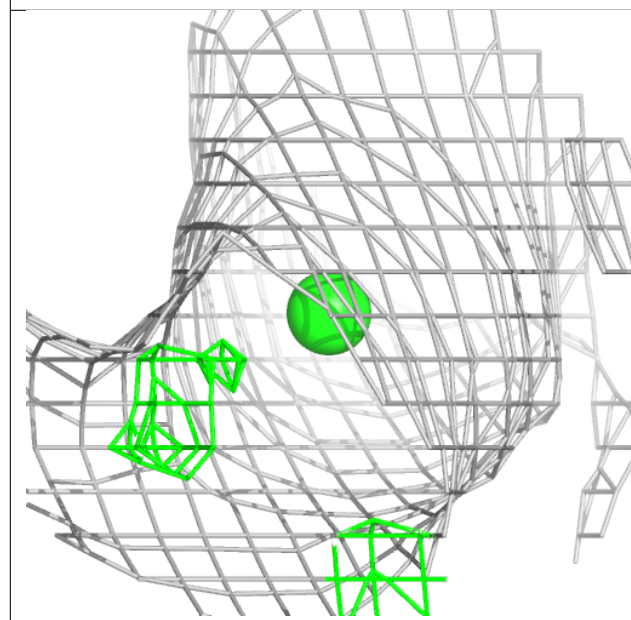

Electron density around CL B 309:

$2mF_o-DF_c$ (at 0.7 rmsd) in gray
 mF_o-DF_c (at 3 rmsd) in purple (negative)
and green (positive)

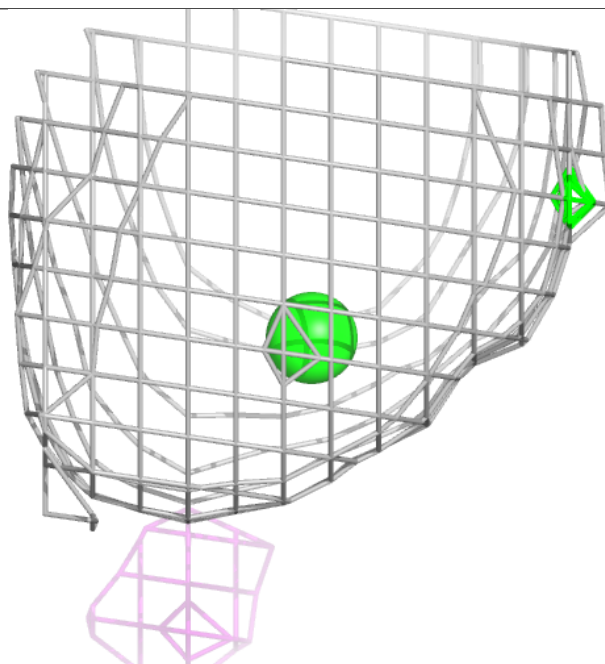
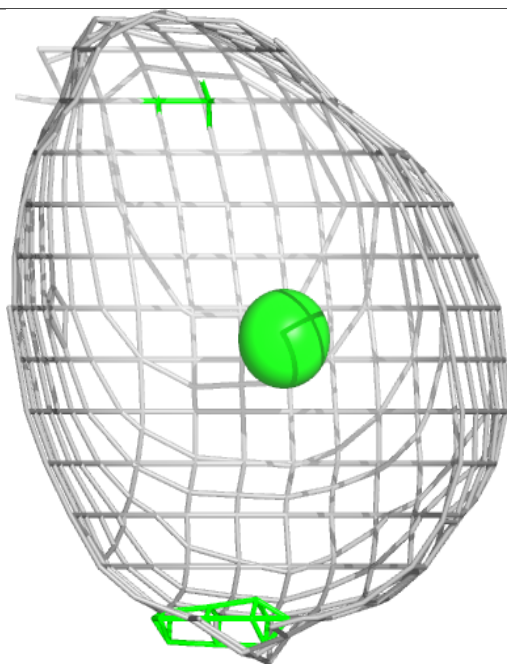
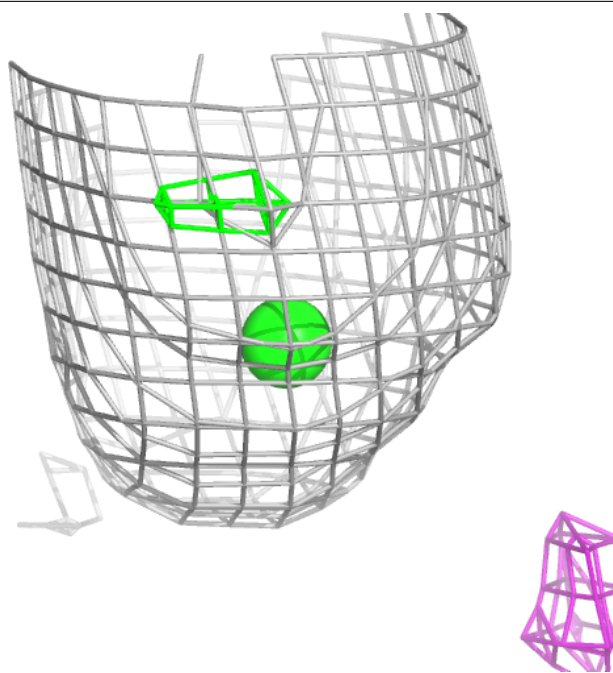

Electron density around AU C 304:

$2mF_o-DF_c$ (at 0.7 rmsd) in gray
 mF_o-DF_c (at 3 rmsd) in purple (negative)
and green (positive)

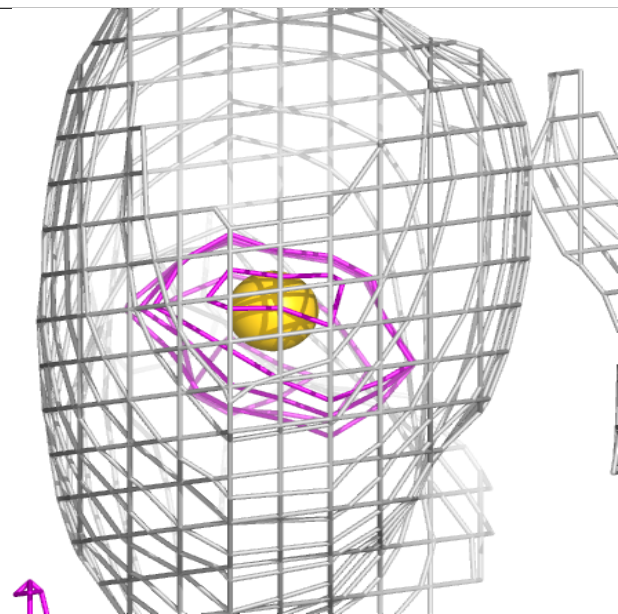
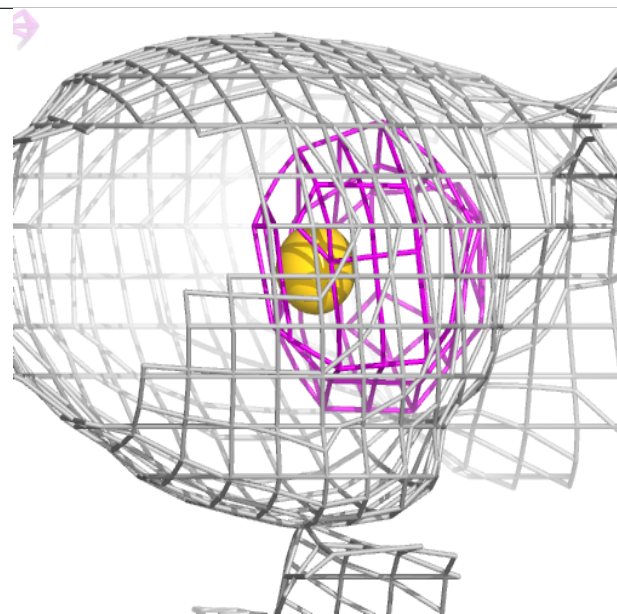
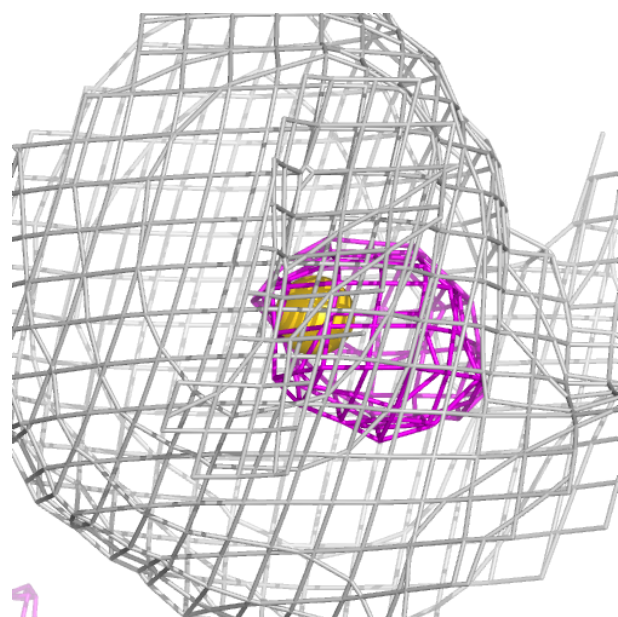

Electron density around AU A 304:

$2mF_o-DF_c$ (at 0.7 rmsd) in gray
 mF_o-DF_c (at 3 rmsd) in purple (negative)
and green (positive)

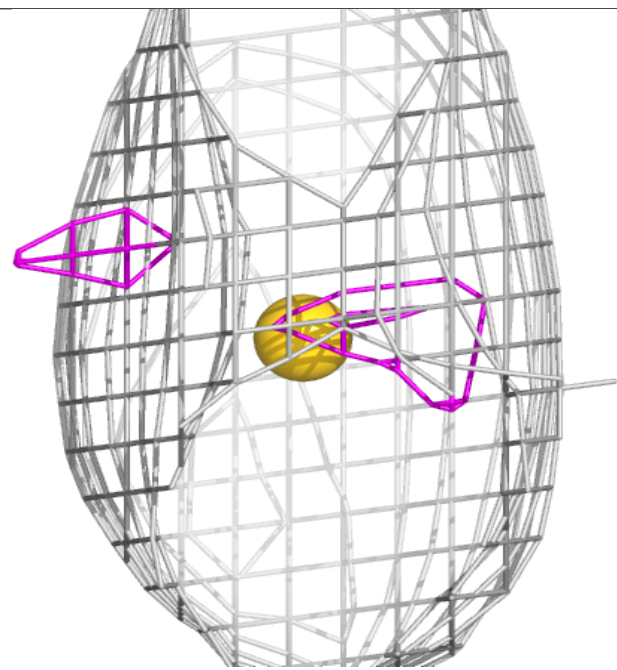
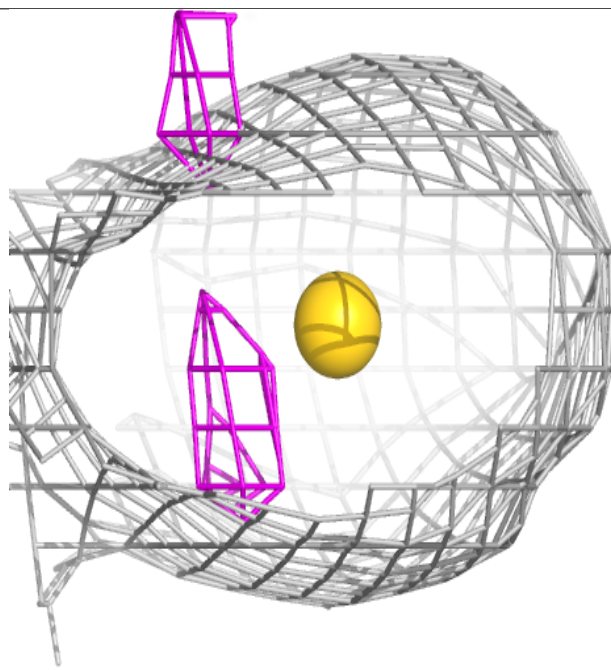
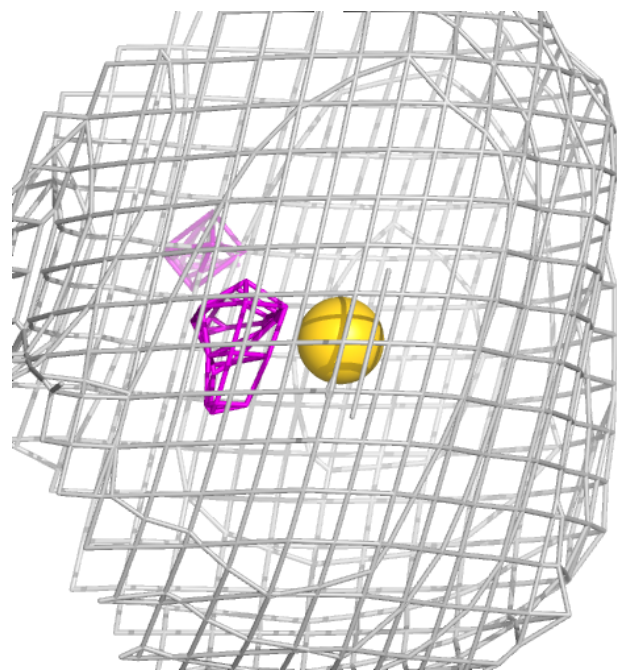

Electron density around CL D 306:

$2mF_o-DF_c$ (at 0.7 rmsd) in gray
 mF_o-DF_c (at 3 rmsd) in purple (negative)
and green (positive)

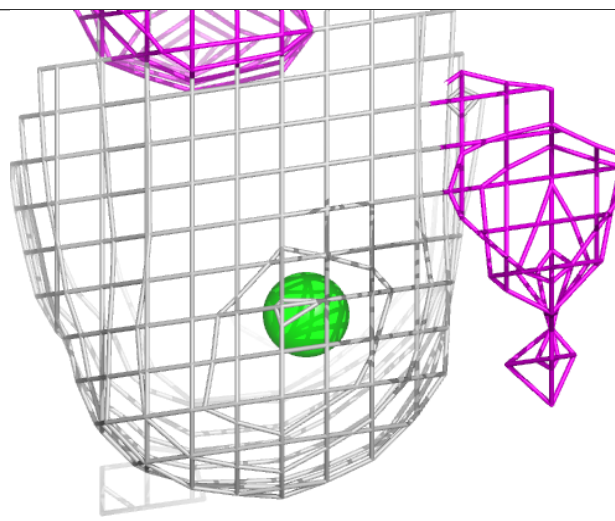
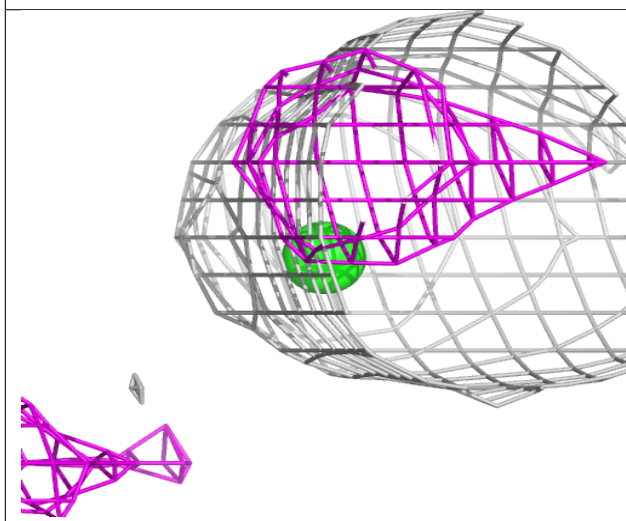
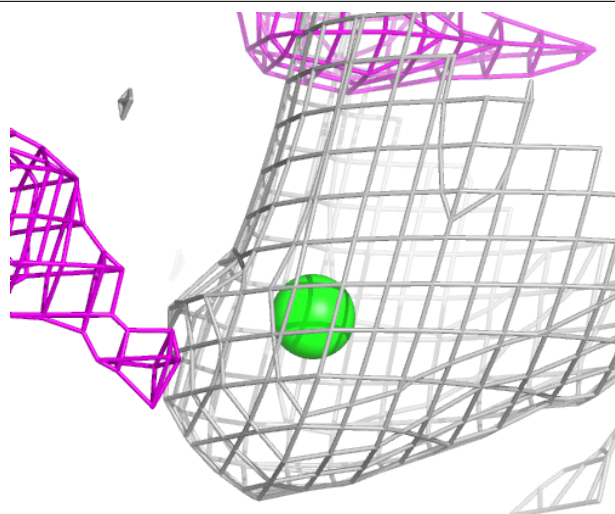

Electron density around AU C 306:

$2mF_o-DF_c$ (at 0.7 rmsd) in gray
 mF_o-DF_c (at 3 rmsd) in purple (negative)
and green (positive)

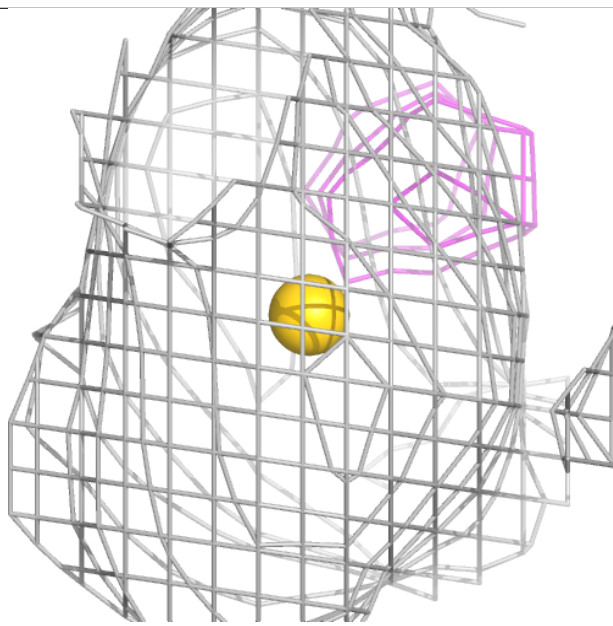
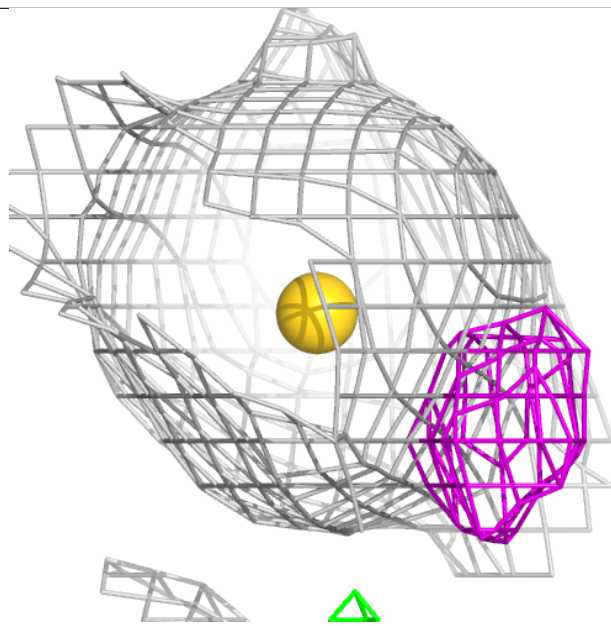
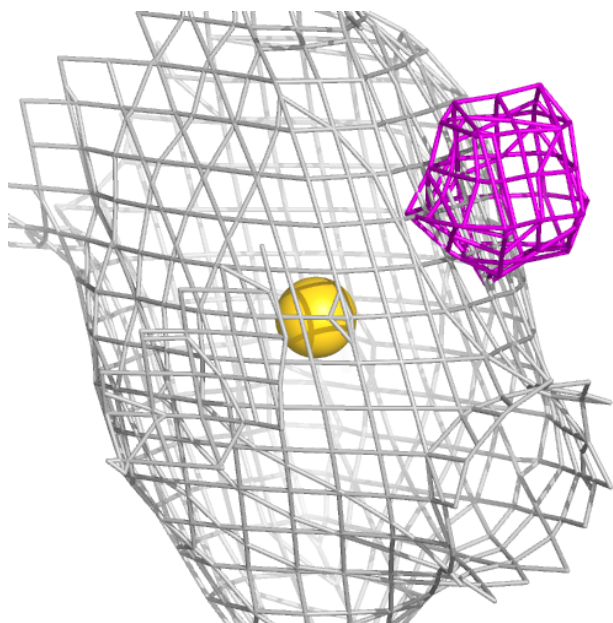

Electron density around CL E 307:

$2mF_o-DF_c$ (at 0.7 rmsd) in gray
 mF_o-DF_c (at 3 rmsd) in purple (negative)
and green (positive)

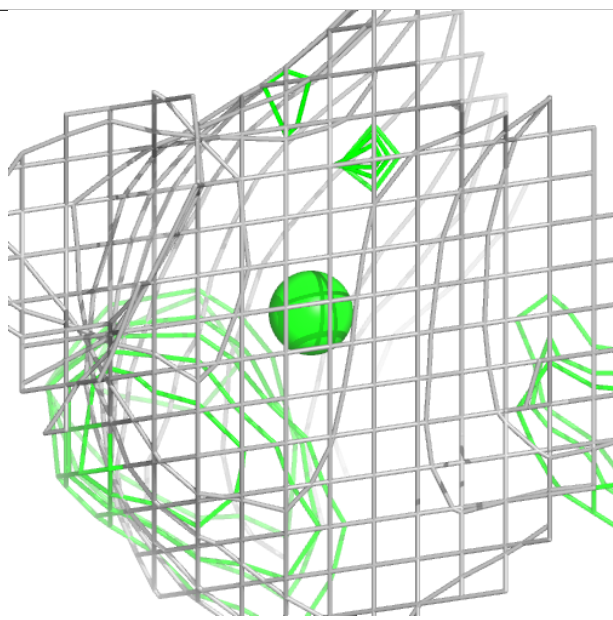
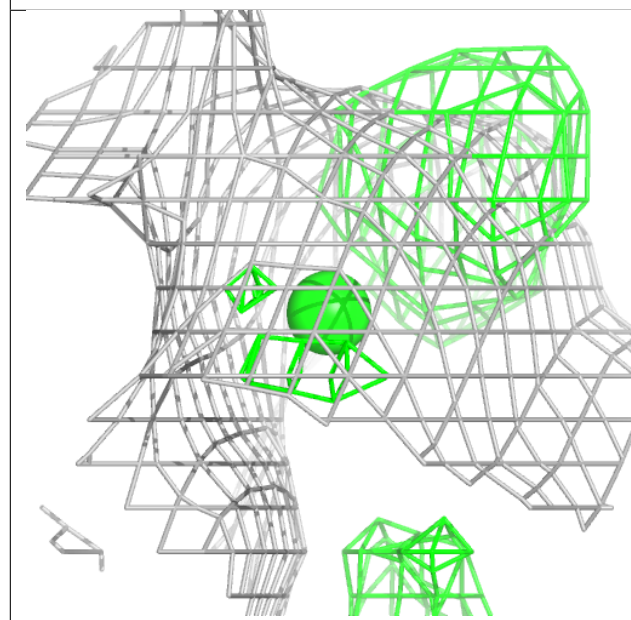
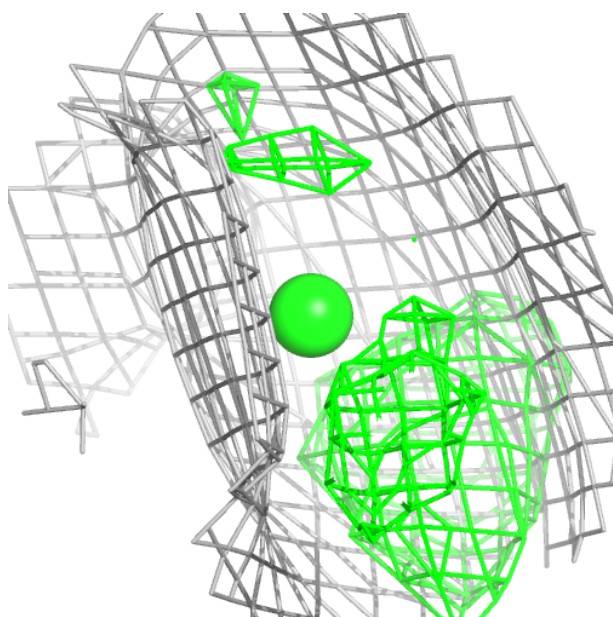

Electron density around CL F 305:

$2mF_o-DF_c$ (at 0.7 rmsd) in gray
 mF_o-DF_c (at 3 rmsd) in purple (negative)
and green (positive)

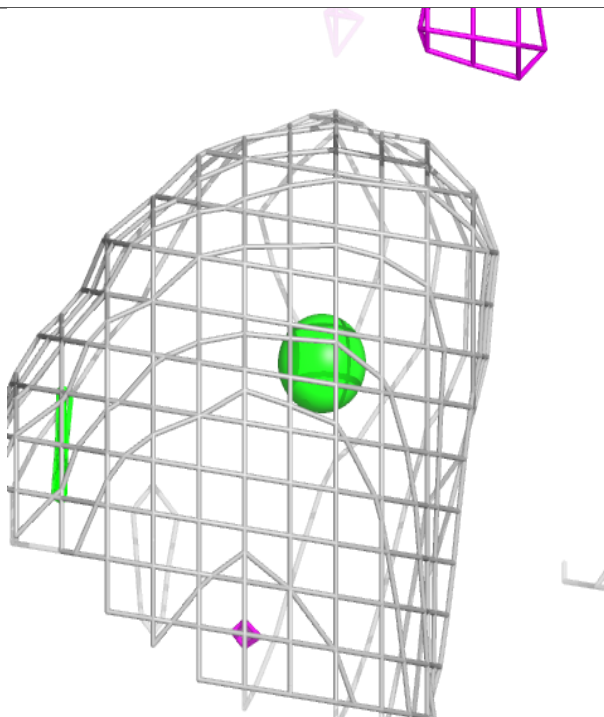
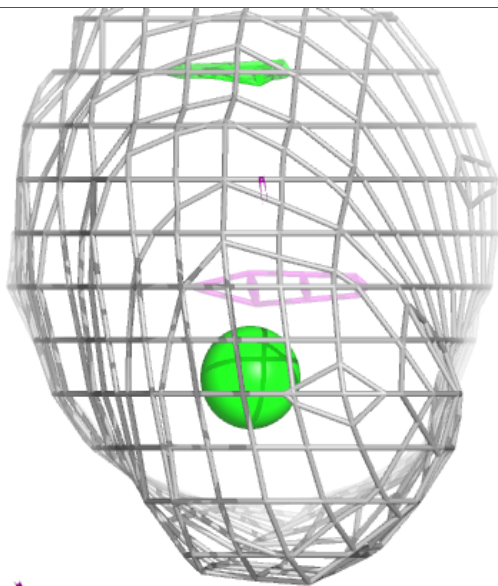
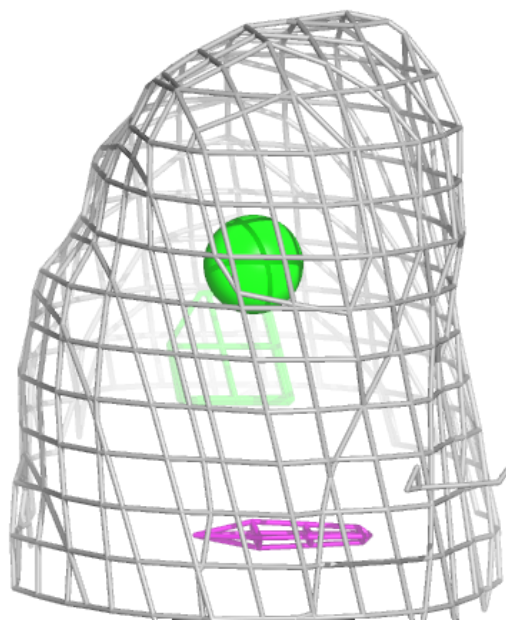

Electron density around AU C 307:

$2mF_o-DF_c$ (at 0.7 rmsd) in gray
 mF_o-DF_c (at 3 rmsd) in purple (negative)
and green (positive)

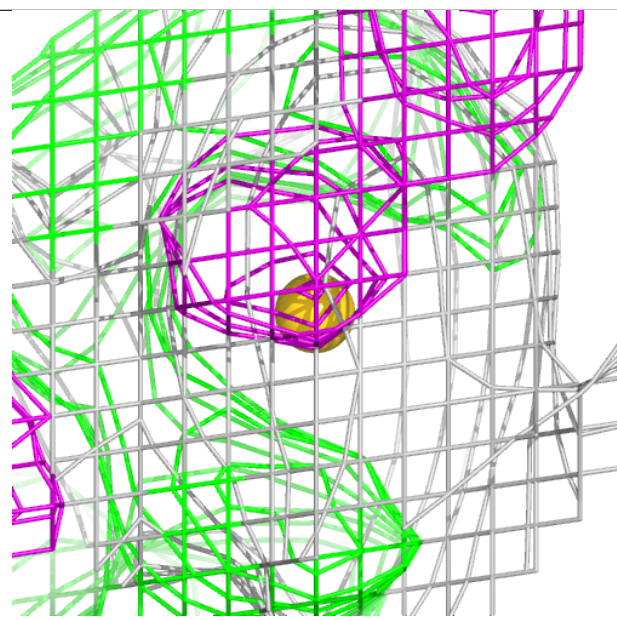
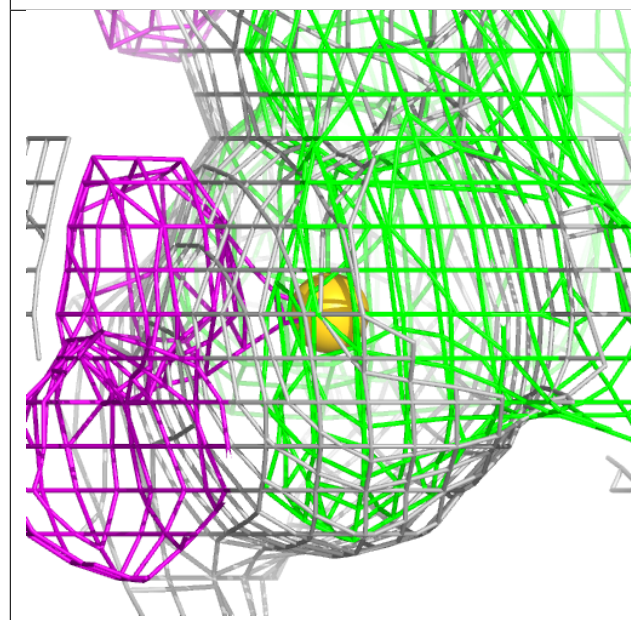
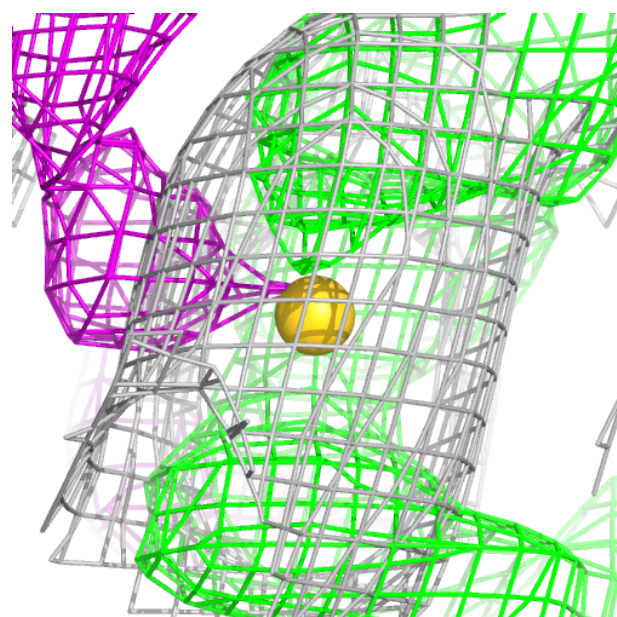

Electron density around AU D 302:

$2mF_o-DF_c$ (at 0.7 rmsd) in gray
 mF_o-DF_c (at 3 rmsd) in purple (negative)
and green (positive)

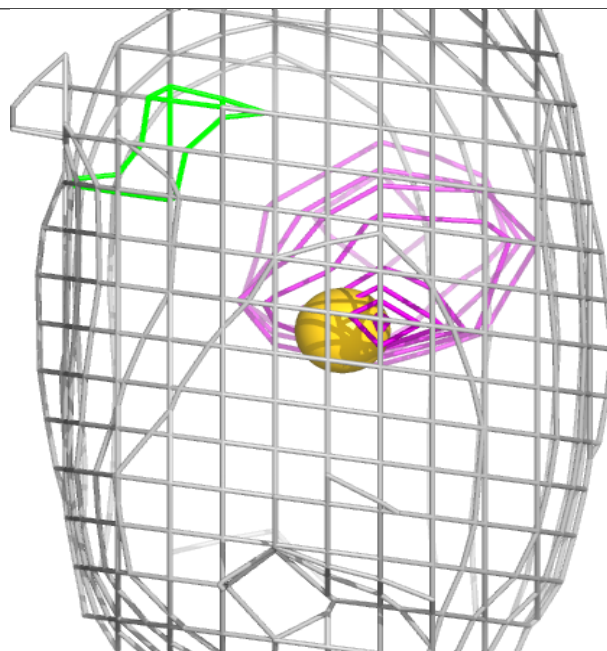
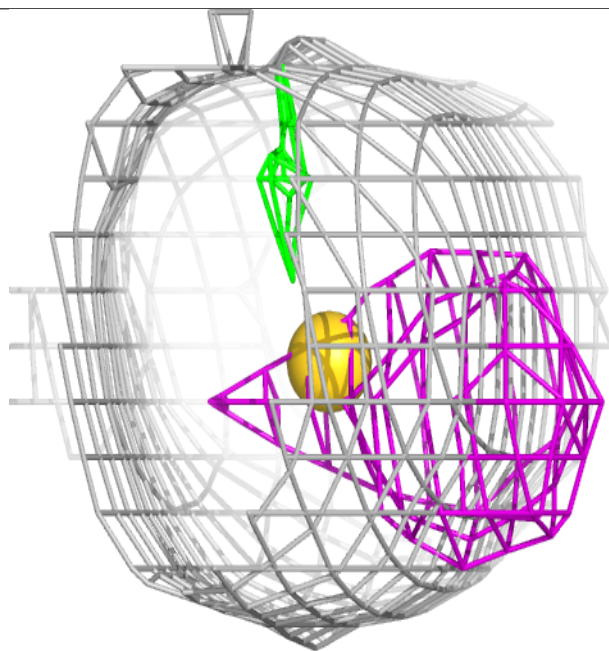
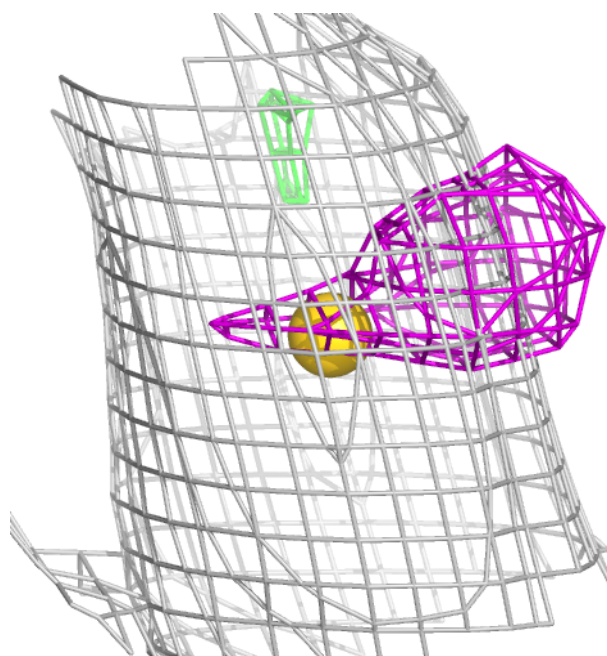

Electron density around AU A 305:

$2mF_o-DF_c$ (at 0.7 rmsd) in gray
 mF_o-DF_c (at 3 rmsd) in purple (negative)
and green (positive)

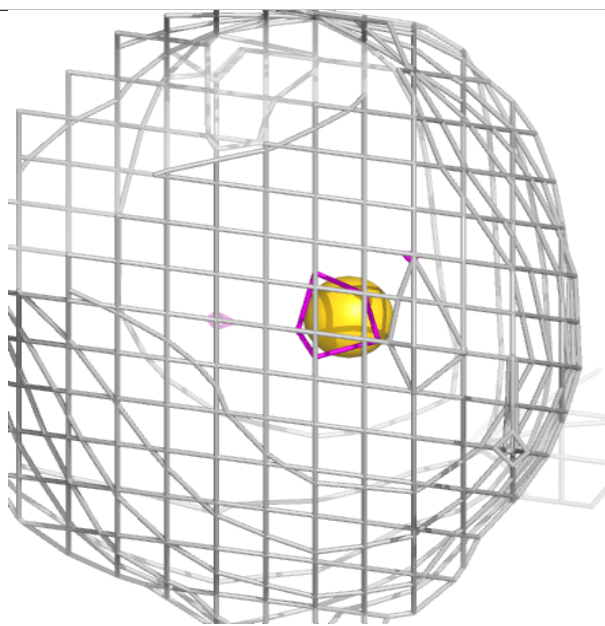
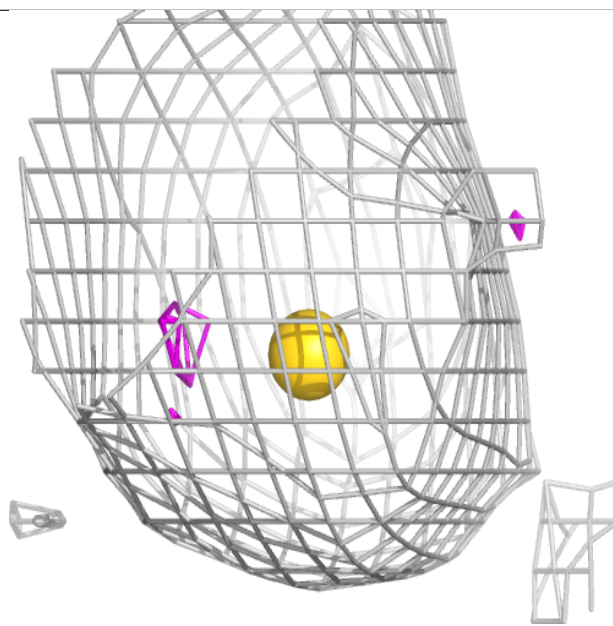
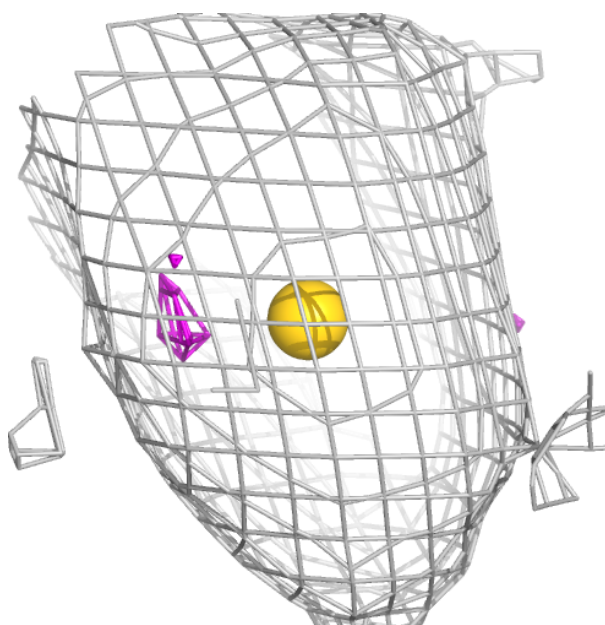

Electron density around AU D 304:

$2mF_o-DF_c$ (at 0.7 rmsd) in gray
 mF_o-DF_c (at 3 rmsd) in purple (negative)
and green (positive)

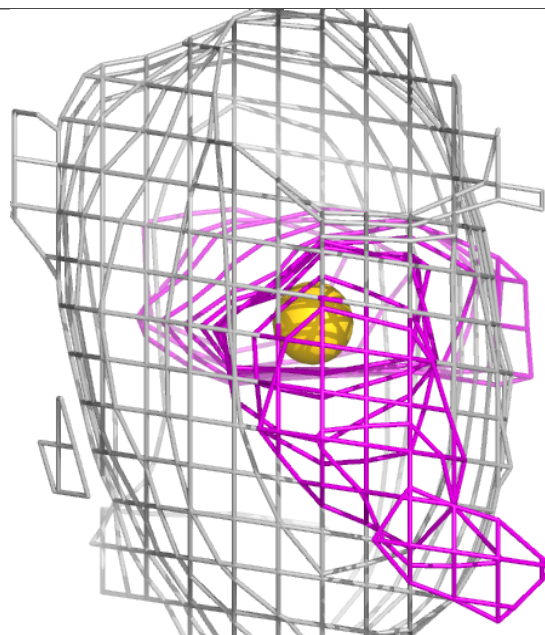
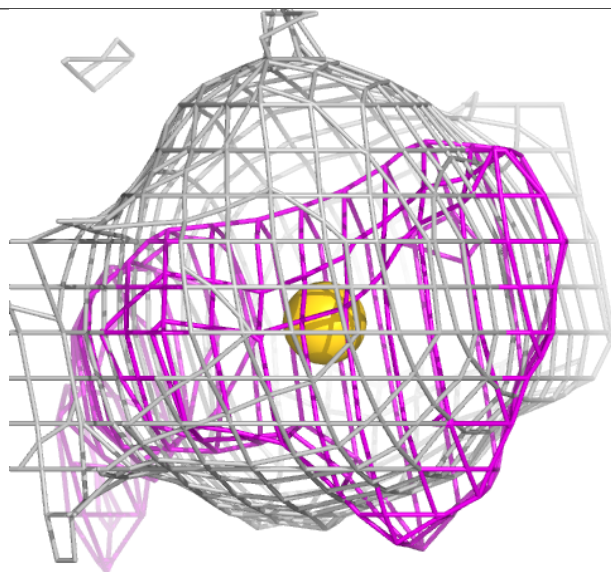
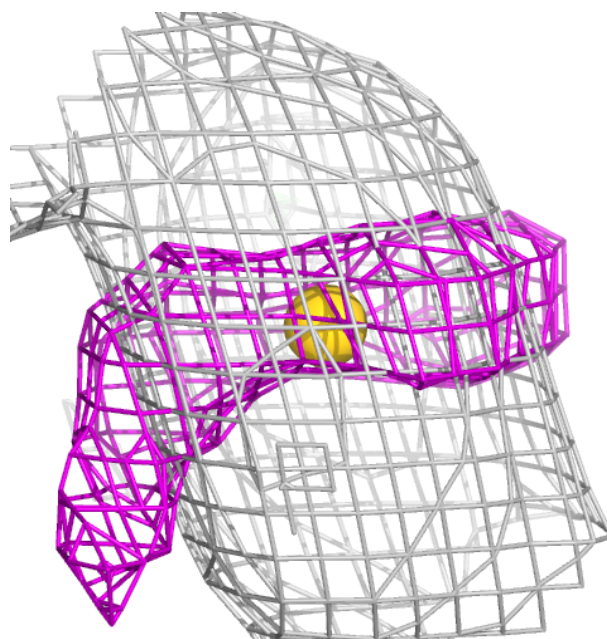

Electron density around AU B 302:

$2mF_o-DF_c$ (at 0.7 rmsd) in gray
 mF_o-DF_c (at 3 rmsd) in purple (negative)
and green (positive)

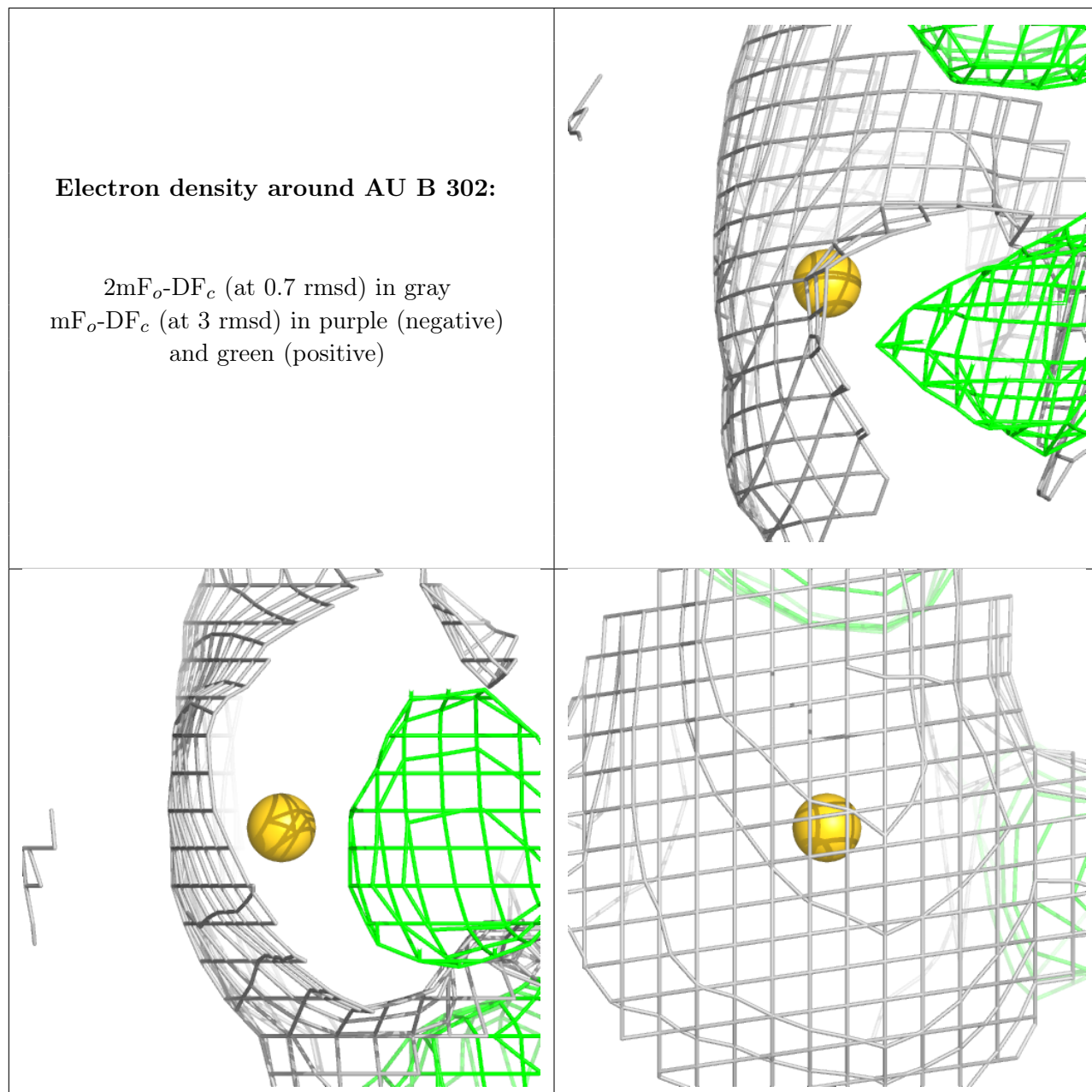

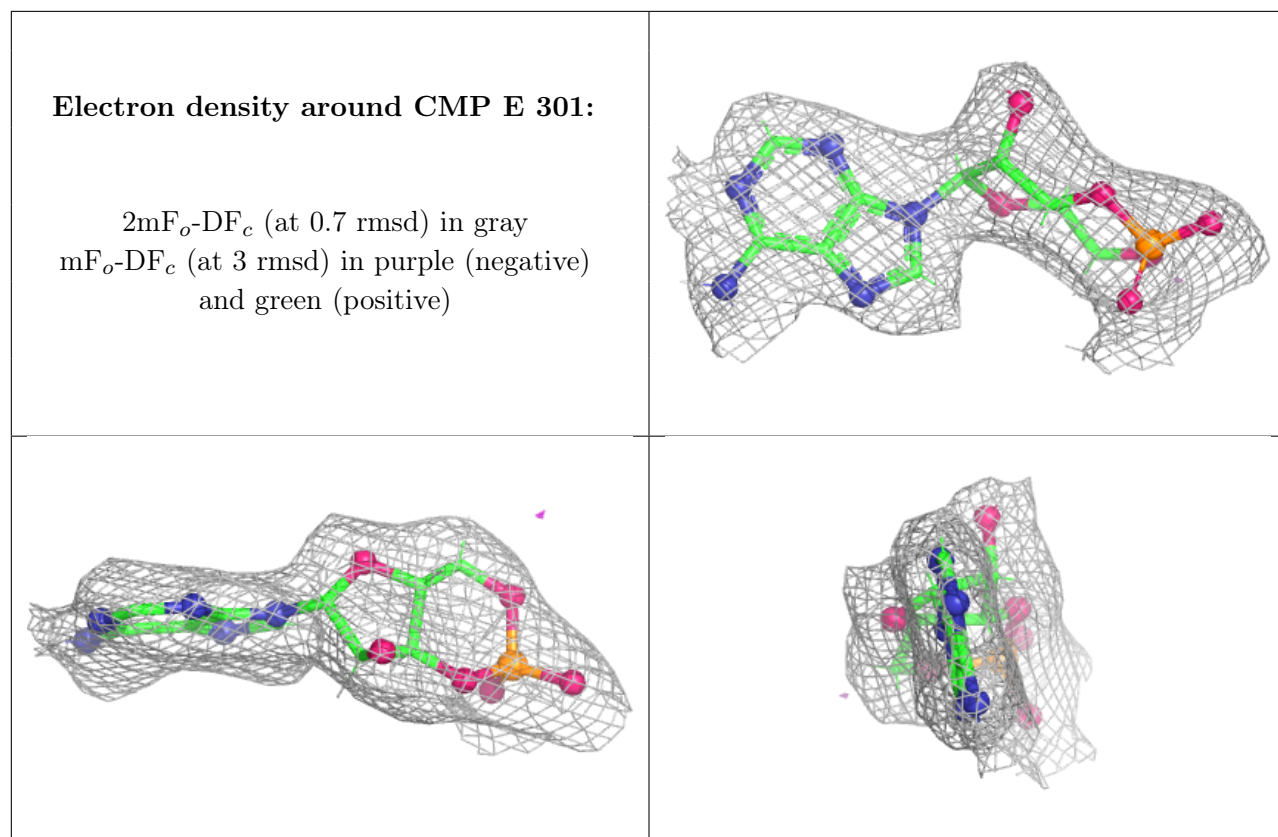

6.5 Other polymers [i](#)

There are no such residues in this entry.