



## wwPDB EM Validation Summary Report ⓘ

Mar 10, 2026 – 01:41 AM UTC

PDB ID : 7FDA / pdb\_00007fda  
EMDB ID : EMD-31538  
Title : CryoEM Structure of Reconstituted V-ATPase, state1  
Authors : Khan, M.M.; Lee, S.; Oot, R.A.; Couch-Cardel, S.; KIm, H.; Wilkens, S.; Roh, S.H.  
Deposited on : 2021-07-16  
Resolution : 4.20 Å(reported)

This is a wwPDB EM Validation Summary Report for a publicly released PDB entry.

We welcome your comments at [validation@mail.wwpdb.org](mailto:validation@mail.wwpdb.org)

A user guide is available at

<https://www.wwpdb.org/validation/2017/EMValidationReportHelp>

with specific help available everywhere you see the ⓘ symbol.

The types of validation reports are described at

<http://www.wwpdb.org/validation/2017/FAQs#types>.

---

The following versions of software and data (see [references ⓘ](#)) were used in the production of this report:

EMDB validation analysis : 0.0.1.dev132  
MolProbity : 4-5-2 with Phenix2.0  
Percentile statistics : 20250101.v01 (using entries in the PDB archive January 1st 2025)  
EM percentile statistics : 202505.v01 (Using data in the EMDB archive up until May 2025)  
MapQ : 1.9.13  
Ideal geometry (proteins) : Engh & Huber (2001)  
Ideal geometry (DNA, RNA) : Parkinson et al. (1996)  
Validation Pipeline (wwPDB-VP) : 2.49

# 1 Overall quality at a glance i

The following experimental techniques were used to determine the structure:  
*ELECTRON MICROSCOPY*

The reported resolution of this entry is 4.20 Å.

Percentile scores (ranging between 0-100) for global validation metrics of the entry are shown in the following graphic. The table shows the number of entries on which the scores are based.

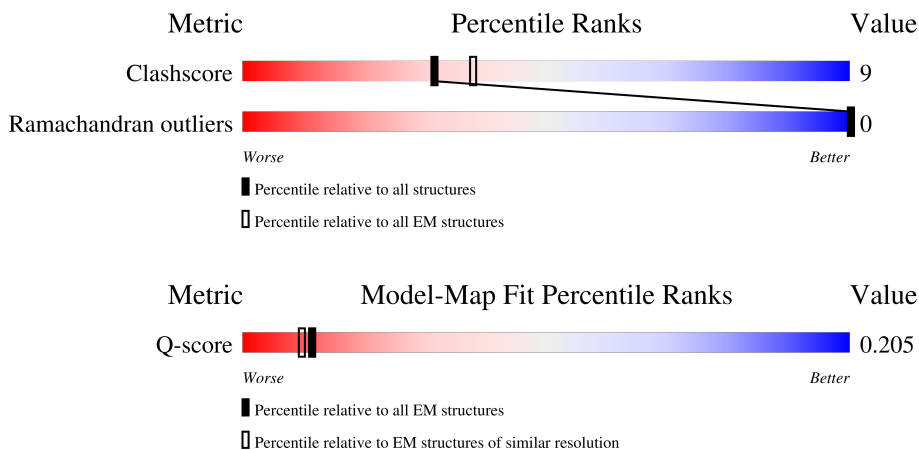











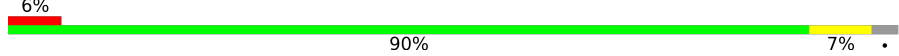





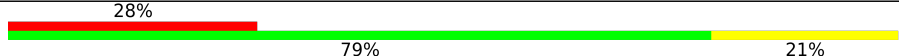
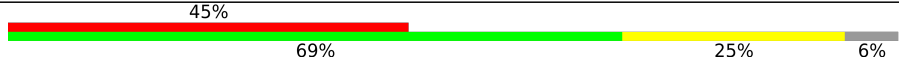
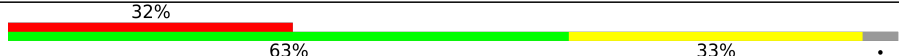

Metric	Whole archive (#Entries)	EM structures (#Entries)	Similar EM resolution (#Entries, resolution range(Å))
Clashscore	229148	23984	-
Ramachandran outliers	224038	23583	-
Q-score	-	25397	5410 ( 3.70 - 4.70 )

The table below summarises the geometric issues observed across the polymeric chains and their fit to the map. The red, orange, yellow and green segments of the bar indicate the fraction of residues that contain outliers for  $\geq 3$ , 2, 1 and 0 types of geometric quality criteria respectively. A grey segment represents the fraction of residues that are not modelled. The numeric value for each fraction is indicated below the corresponding segment, with a dot representing fractions  $\leq 5\%$ . The upper red bar (where present) indicates the fraction of residues that have poor fit to the EM map (all-atom inclusion  $< 40\%$ ). The numeric value is given above the bar.

Mol	Chain	Length	Quality of chain
1	A	617	<span style="display: inline-block; width: 100%; height: 15px; background: linear-gradient(to right, red, orange, yellow, green, grey);"></span> 82% 14% .
1	C	617	<span style="display: inline-block; width: 100%; height: 15px; background: linear-gradient(to right, red, orange, yellow, green, grey);"></span> 84% 12% .
1	E	617	<span style="display: inline-block; width: 100%; height: 15px; background: linear-gradient(to right, red, orange, yellow, green, grey);"></span> 85% 12% .
2	B	517	<span style="display: inline-block; width: 100%; height: 15px; background: linear-gradient(to right, red, orange, yellow, green, grey);"></span> 80% 11% 9%
2	D	517	<span style="display: inline-block; width: 100%; height: 15px; background: linear-gradient(to right, red, orange, yellow, green, grey);"></span> 79% 11% 9%

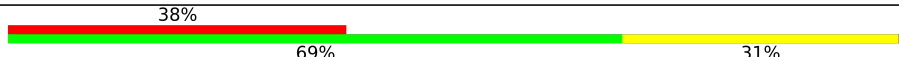
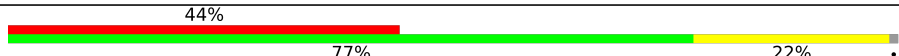
*Continued on next page...*

Continued from previous page...

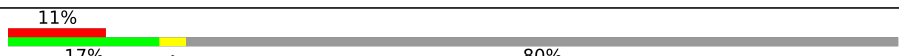
Mol	Chain	Length	Quality of chain
2	F	517	 81% 10% 9%
3	G	233	 90% 7%
3	I	233	 82% 15%
3	K	233	 88% 9%
4	H	122	 74% 17% 9%
4	J	122	 84% 7% 9%
4	L	122	 77% 14% 9%
5	M	256	 71% 14% 15%
6	N	118	 79% 19%
7	O	392	 74% 26%
8	P	469	 68% 28%
9	Q	840	 58% 31% 11%
10	S	345	 79% 21%
11	T	213	 69% 25% 6%
12	U	164	 63% 33%
13	V	160	 73% 26%
13	W	160	 69% 30%
13	X	160	 71% 29%
13	Y	160	 73% 27%
13	Z	160	 69% 31%
13	a	160	 77% 22%
13	b	160	 74% 26%
13	c	160	 68% 31%
14	d	73	 63% 32% 5%
15	e	265	 17% 80%

Continued on next page...

*Continued from previous page...*

Mol	Chain	Length	Quality of chain
16	f	85	 <p>A horizontal bar chart representing the quality of chain. The bar is divided into four segments: a red segment (44%), a green segment (75%), a yellow segment (14%), and a grey segment (11%). The percentages are labeled above or below the corresponding segments.</p>

## 2 Entry composition [i](#)

There are 16 unique types of molecules in this entry. The entry contains 64497 atoms, of which 0 are hydrogens and 0 are deuteriums.

In the tables below, the AltConf column contains the number of residues with at least one atom in alternate conformation and the Trace column contains the number of residues modelled with at most 2 atoms.

- Molecule 1 is a protein called Yeast Vacuolar ATPase A subunit.

Mol	Chain	Residues	Atoms					AltConf	Trace
			Total	C	N	O	S		
1	A	594	Total	C	N	O	S	0	0
			4586	2909	761	896	20		
1	C	594	Total	C	N	O	S	0	0
			4586	2909	761	896	20		
1	E	594	Total	C	N	O	S	0	0
			4586	2909	761	896	20		

- Molecule 2 is a protein called V-type proton ATPase subunit B.

Mol	Chain	Residues	Atoms					AltConf	Trace
			Total	C	N	O	S		
2	B	471	Total	C	N	O	S	0	0
			3706	2347	634	713	12		
2	D	468	Total	C	N	O	S	0	0
			3681	2332	631	706	12		
2	F	470	Total	C	N	O	S	0	0
			3699	2342	633	712	12		

- Molecule 3 is a protein called V-type proton ATPase subunit E.

Mol	Chain	Residues	Atoms					AltConf	Trace
			Total	C	N	O	S		
3	G	225	Total	C	N	O	S	0	0
			1802	1131	309	357	5		
3	I	225	Total	C	N	O	S	0	0
			1802	1131	309	357	5		
3	K	225	Total	C	N	O	S	0	0
			1802	1131	309	357	5		

- Molecule 4 is a protein called V-type proton ATPase subunit G.

Mol	Chain	Residues	Atoms				AltConf	Trace
			Total	C	N	O		
4	H	111	Total	C	N	O	0	0
			871	546	153	172		

*Continued on next page...*

*Continued from previous page...*

Mol	Chain	Residues	Atoms				AltConf	Trace
4	J	111	Total	C	N	O	0	0
			871	546	153	172		
4	L	111	Total	C	N	O	0	0
			871	546	153	172		

- Molecule 5 is a protein called V-type proton ATPase subunit D.

Mol	Chain	Residues	Atoms					AltConf	Trace
5	M	218	Total	C	N	O	S	0	0
			1756	1100	315	336	5		

- Molecule 6 is a protein called V-type proton ATPase subunit F.

Mol	Chain	Residues	Atoms				AltConf	Trace
6	N	115	Total	C	N	O	0	0
			928	589	157	182		

- Molecule 7 is a protein called V-type proton ATPase subunit C.

Mol	Chain	Residues	Atoms					AltConf	Trace
7	O	392	Total	C	N	O	S	0	0
			3121	2005	516	595	5		

- Molecule 8 is a protein called Fusion of yeast V-type proton ATPase subunit H(NT) and human V-type proton ATPase subunit H(CT).

Mol	Chain	Residues	Atoms					AltConf	Trace
8	P	452	Total	C	N	O	S	0	0
			3665	2338	632	682	13		

- Molecule 9 is a protein called Yeast Vacuolar ATPase a subunit.

Mol	Chain	Residues	Atoms					AltConf	Trace
9	Q	747	Total	C	N	O	S	0	0
			6069	3960	986	1088	35		

- Molecule 10 is a protein called V-type proton ATPase subunit d.

Mol	Chain	Residues	Atoms					AltConf	Trace
10	S	344	Total	C	N	O	S	0	0
			2793	1774	453	553	13		

- Molecule 11 is a protein called V-type proton ATPase subunit c''.

Mol	Chain	Residues	Atoms					AltConf	Trace
			Total	C	N	O	S		
11	T	200	1492	995	231	259	7	0	0

- Molecule 12 is a protein called V-type proton ATPase subunit c'.

Mol	Chain	Residues	Atoms					AltConf	Trace
			Total	C	N	O	S		
12	U	157	1139	753	179	195	12	0	0

- Molecule 13 is a protein called V-type proton ATPase subunit c.

Mol	Chain	Residues	Atoms					AltConf	Trace
			Total	C	N	O	S		
13	V	159	1140	751	182	199	8	0	0
13	W	159	1140	751	182	199	8	0	0
13	X	159	1140	751	182	199	8	0	0
13	Y	160	1146	754	183	200	9	0	0
13	Z	159	1140	751	182	199	8	0	0
13	a	159	1140	751	182	199	8	0	0
13	b	160	1146	754	183	200	9	0	0
13	c	159	1140	751	182	199	8	0	0

- Molecule 14 is a protein called V-type proton ATPase subunit e.

Mol	Chain	Residues	Atoms					AltConf	Trace
			Total	C	N	O	S		
14	d	69	553	369	91	86	7	0	0

- Molecule 15 is a protein called V0 assembly protein 1.

Mol	Chain	Residues	Atoms					AltConf	Trace
			Total	C	N	O	S		
15	e	52	403	268	59	74	2	0	0

- Molecule 16 is a protein called Yeast Vacuolar ATPase f subunit.

Mol	Chain	Residues	Atoms					AltConf	Trace
			Total	C	N	O	S		
16	f	76	583	386	94	100	3	0	0



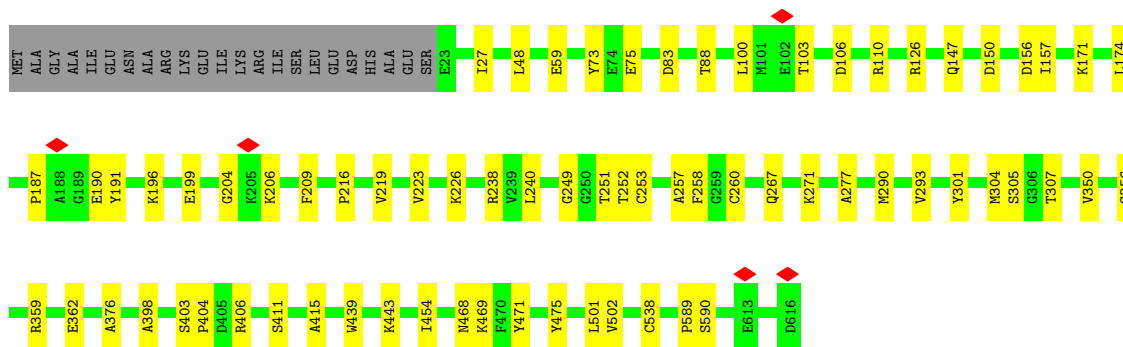

• Molecule 2: V-type proton ATPase subunit B

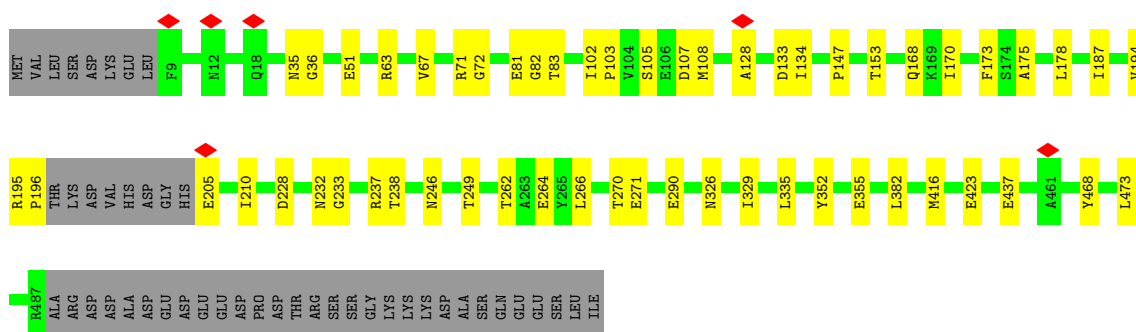
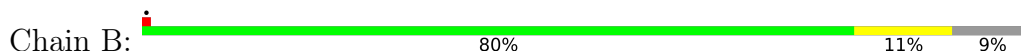

• Molecule 2: V-type proton ATPase subunit B

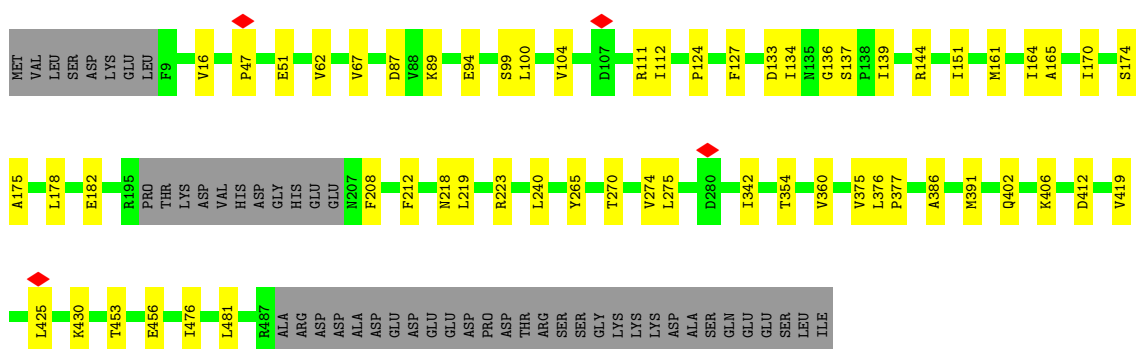
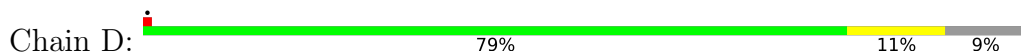

• Molecule 2: V-type proton ATPase subunit B

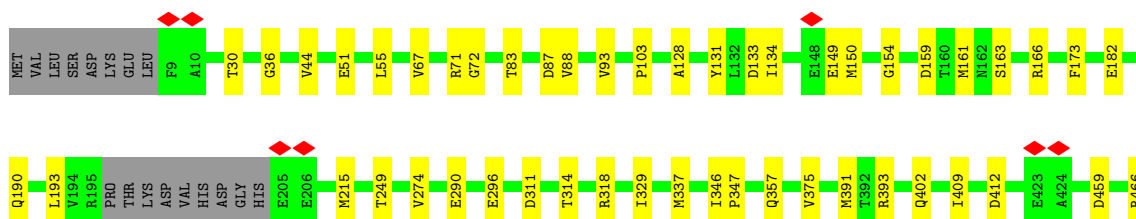
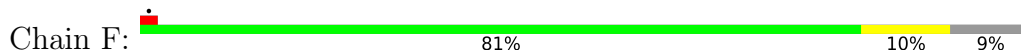

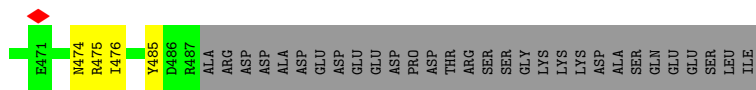

• Molecule 3: V-type proton ATPase subunit E

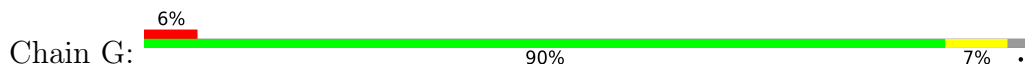

• Molecule 3: V-type proton ATPase subunit E

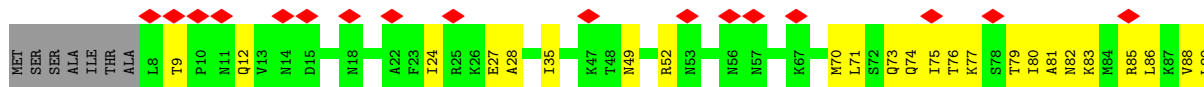
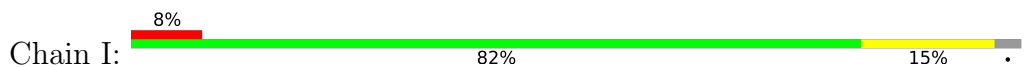

• Molecule 3: V-type proton ATPase subunit E

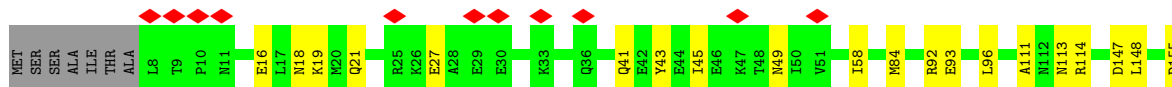
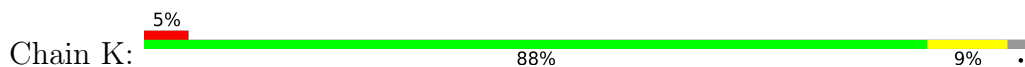

• Molecule 4: V-type proton ATPase subunit G

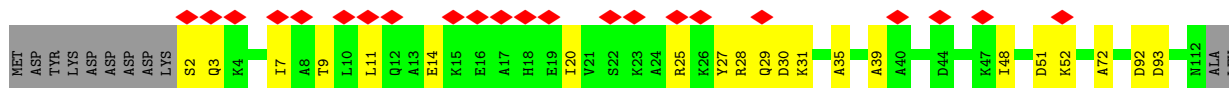
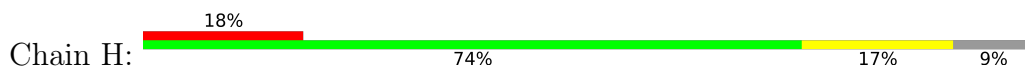

• Molecule 4: V-type proton ATPase subunit G

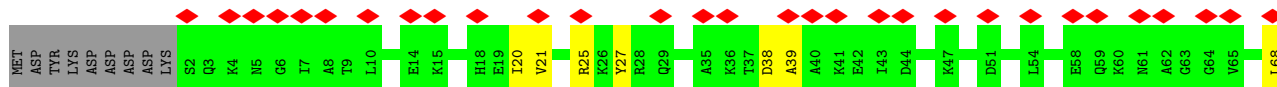
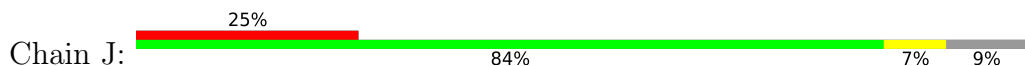



• Molecule 4: V-type proton ATPase subunit G

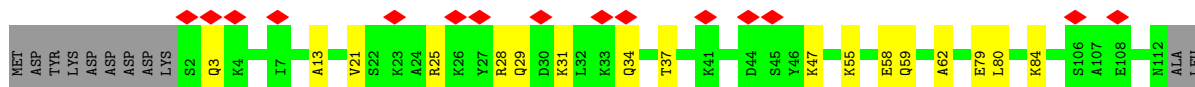
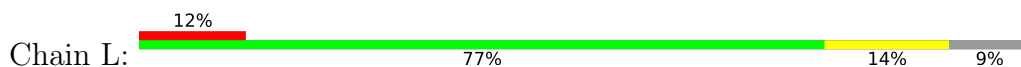

• Molecule 5: V-type proton ATPase subunit D

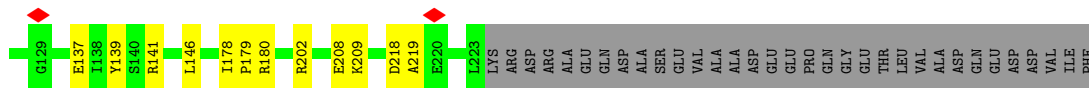
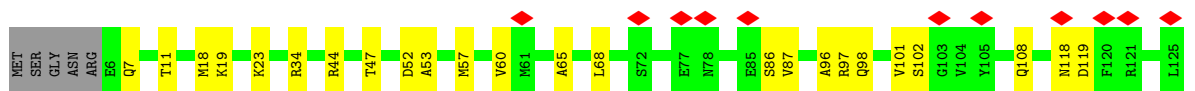

• Molecule 6: V-type proton ATPase subunit F

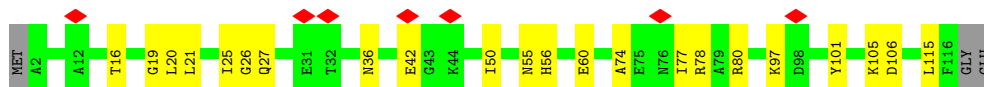
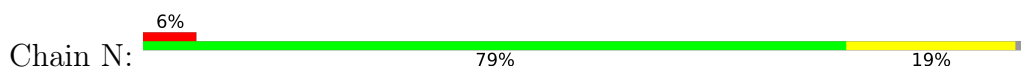

• Molecule 7: V-type proton ATPase subunit C

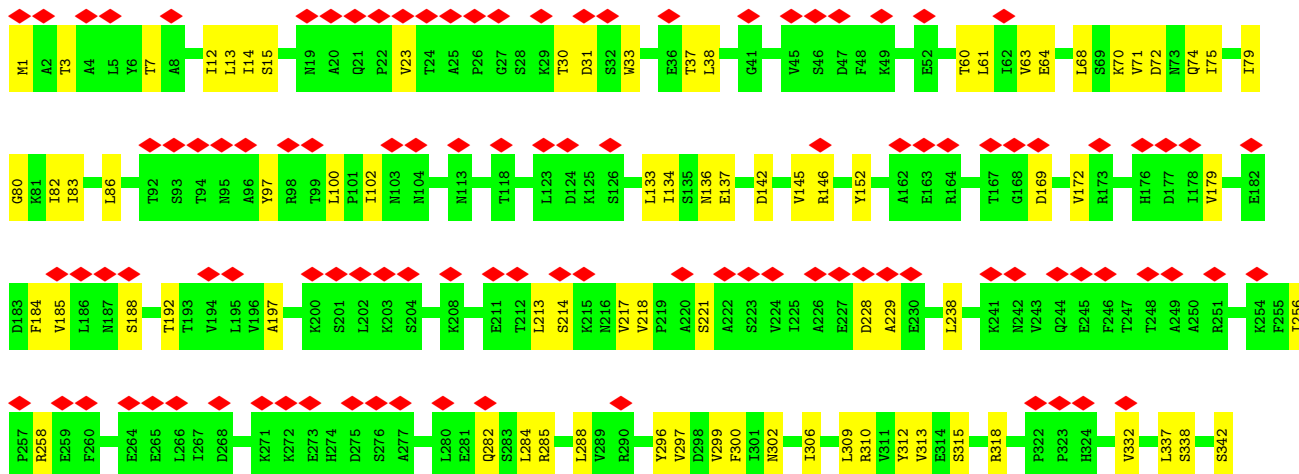
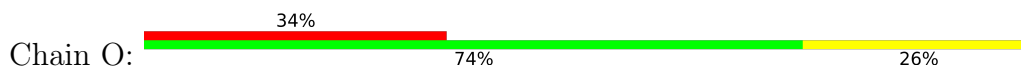

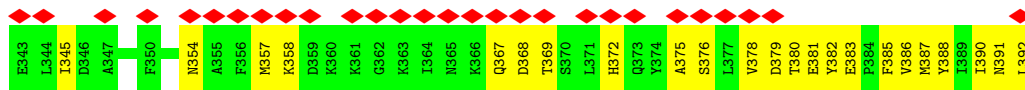

• Molecule 8: Fusion of yeast V-type proton ATPase subunit H(NT) and human V-type proton ATPase subunit H(CT)

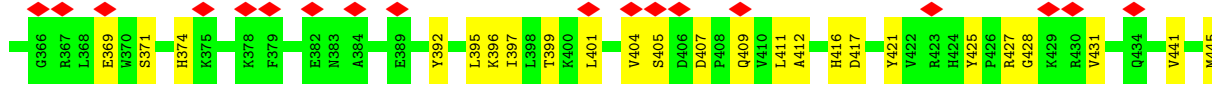
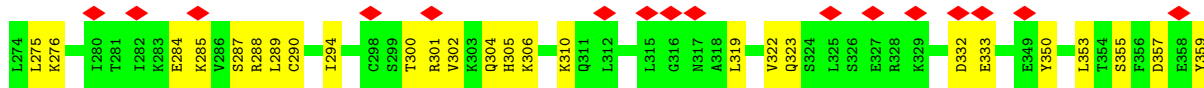
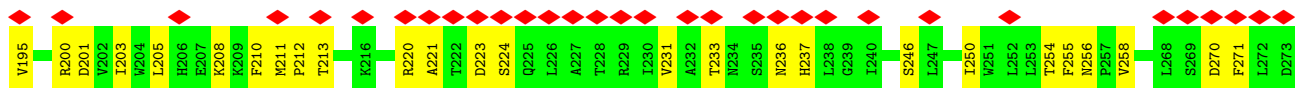
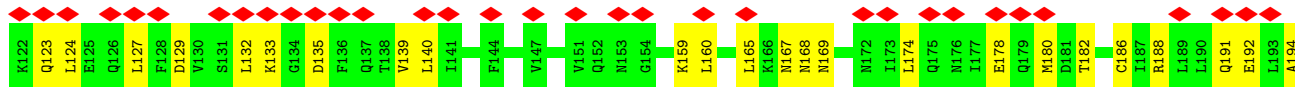
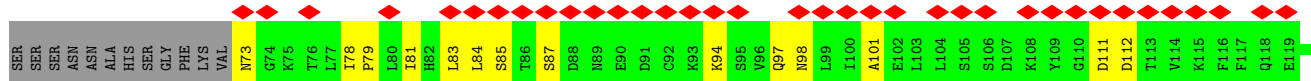
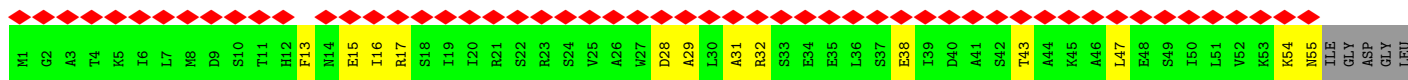
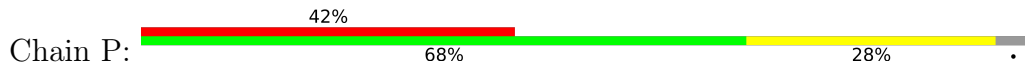

• Molecule 9: Yeast Vacuolar ATPase a subunit

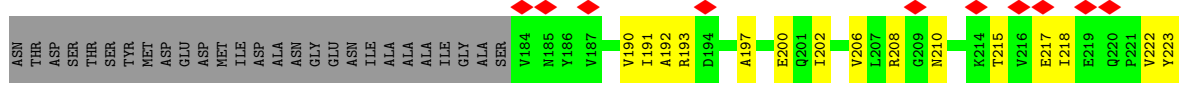
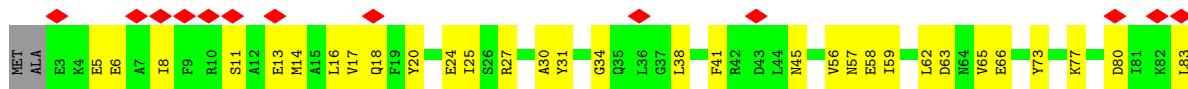

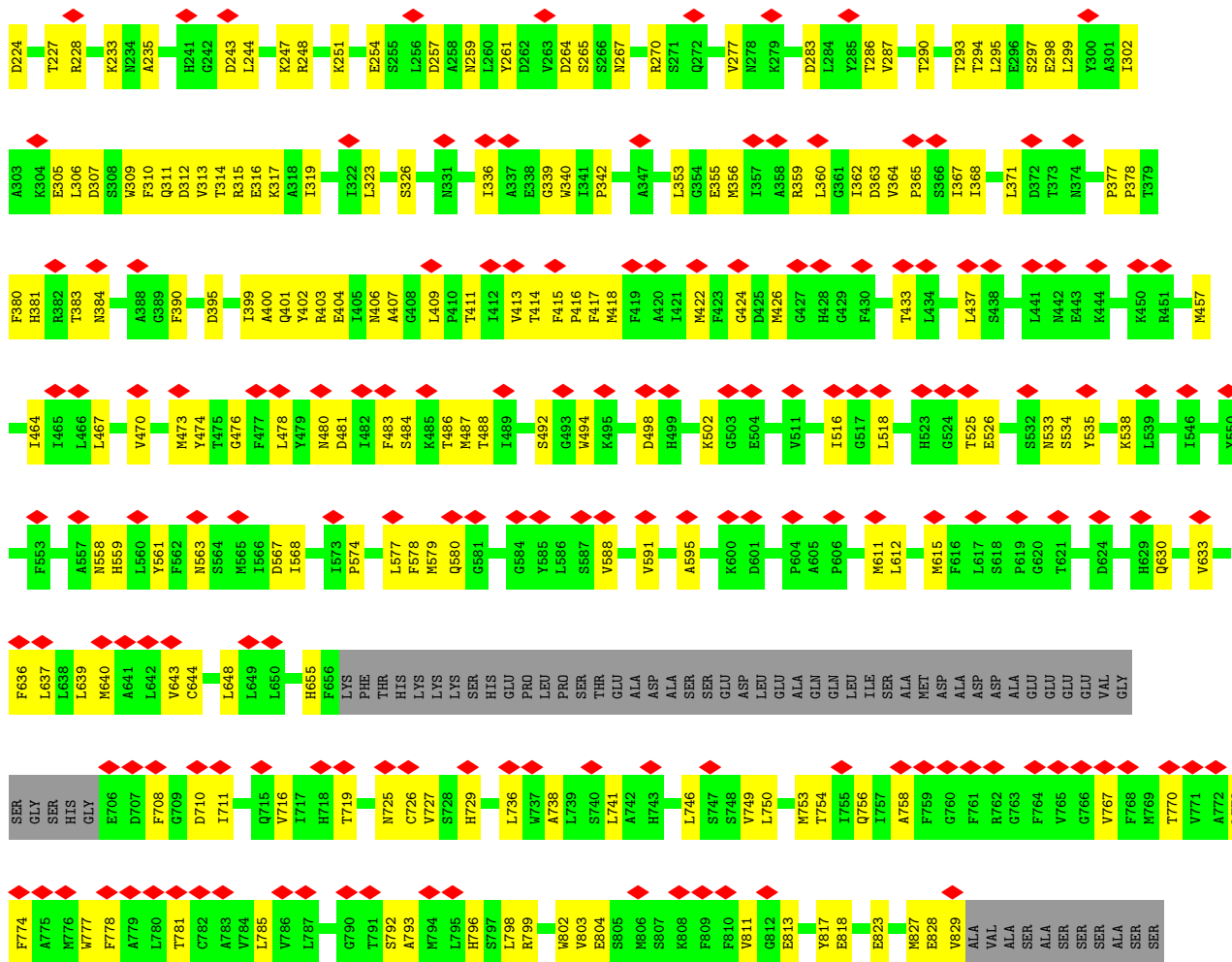

• Molecule 10: V-type proton ATPase subunit d

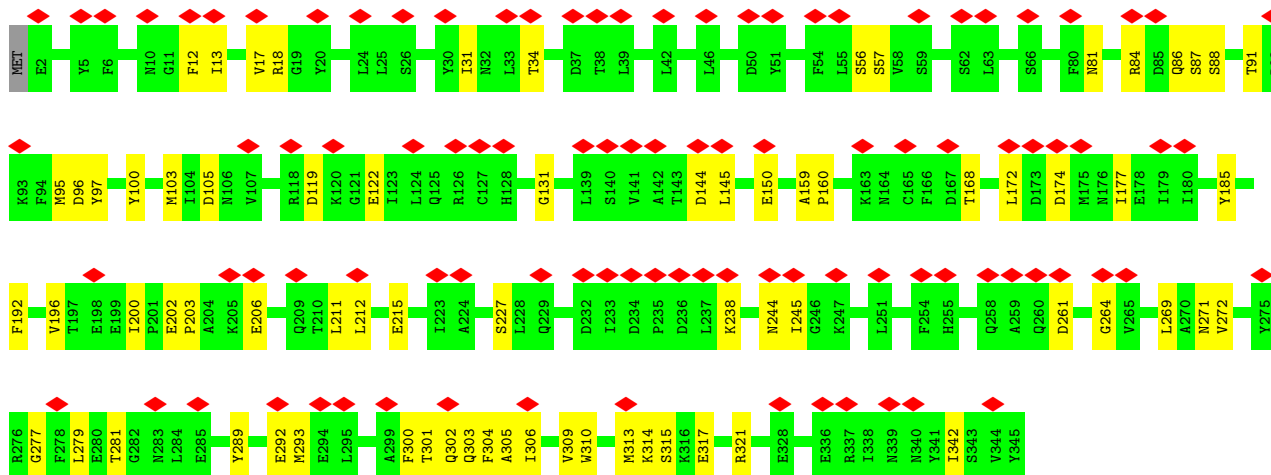
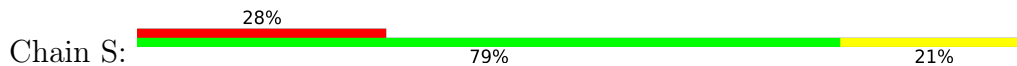

• Molecule 11: V-type proton ATPase subunit c'

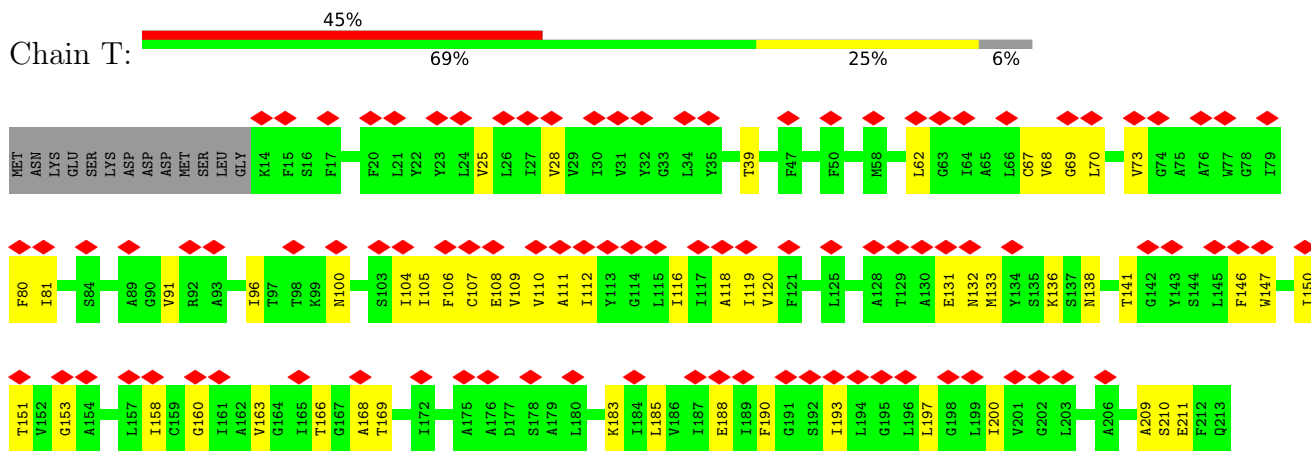

• Molecule 12: V-type proton ATPase subunit c'

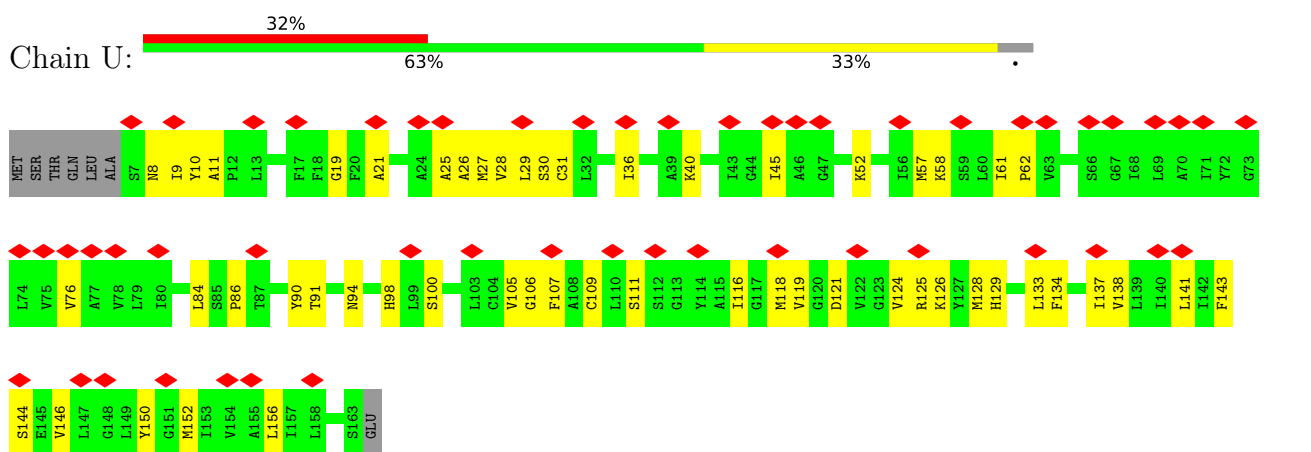

• Molecule 13: V-type proton ATPase subunit c

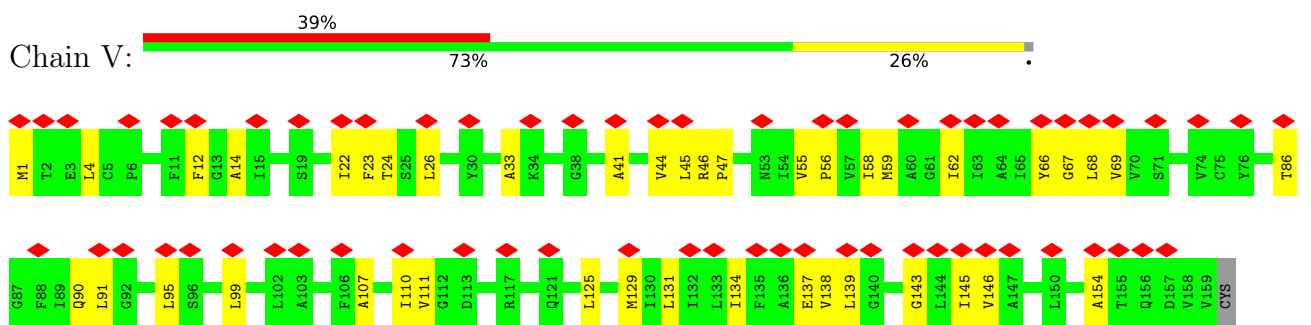

• Molecule 13: V-type proton ATPase subunit c

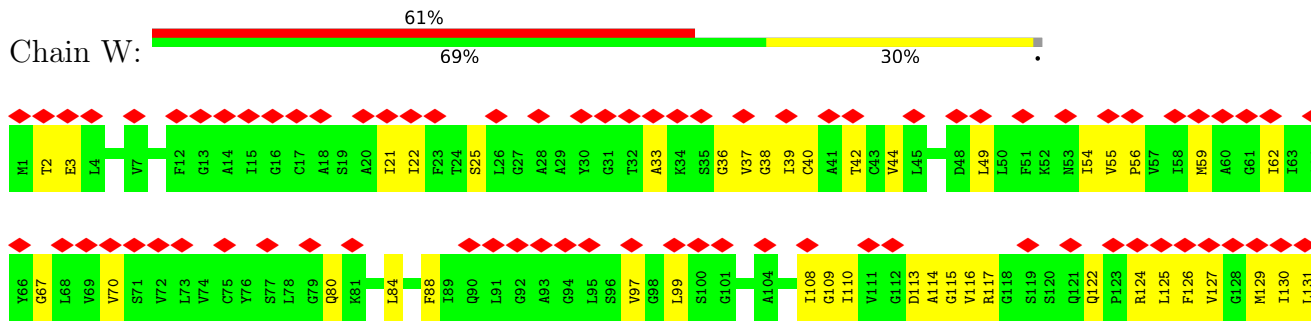

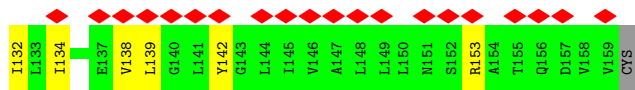

• Molecule 13: V-type proton ATPase subunit c

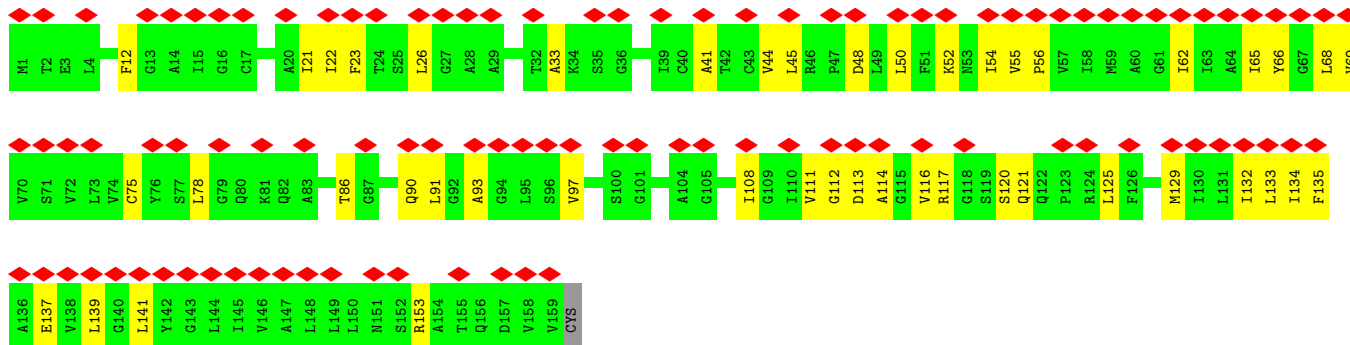

• Molecule 13: V-type proton ATPase subunit c

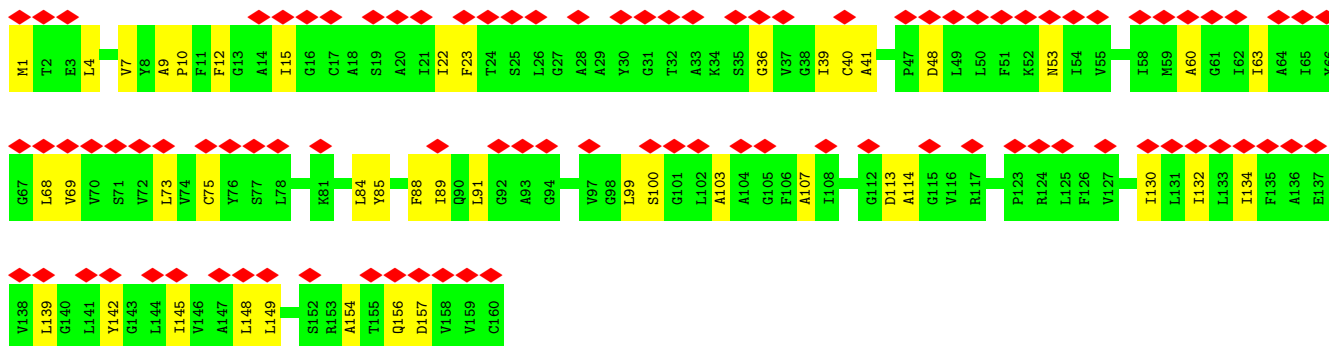
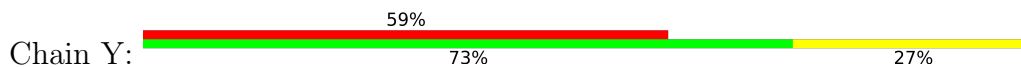

• Molecule 13: V-type proton ATPase subunit c

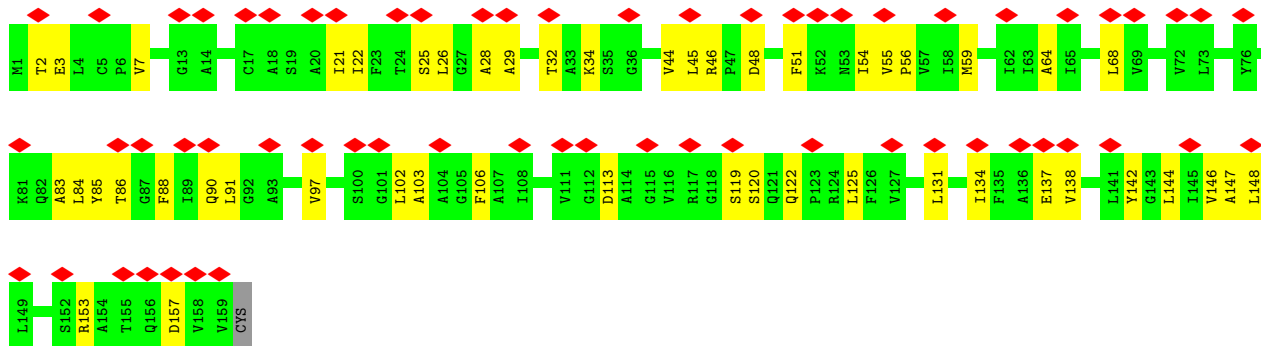

• Molecule 13: V-type proton ATPase subunit c

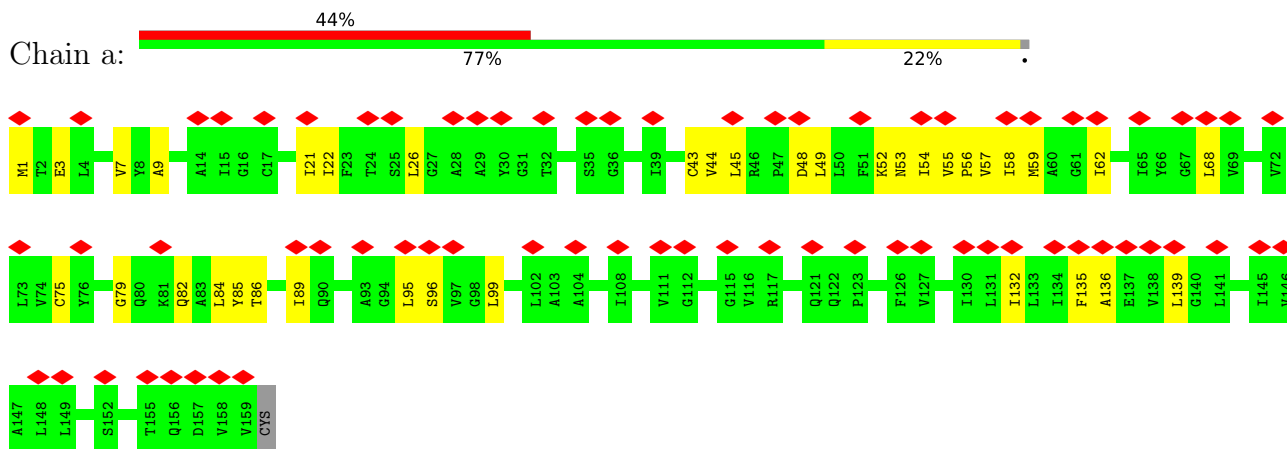

• Molecule 13: V-type proton ATPase subunit c

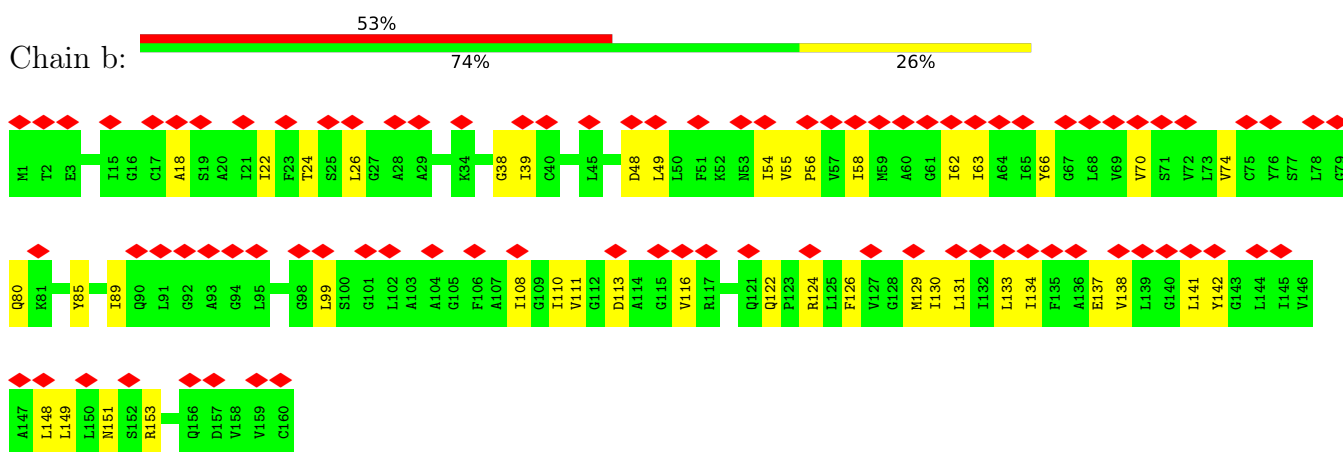

• Molecule 13: V-type proton ATPase subunit c

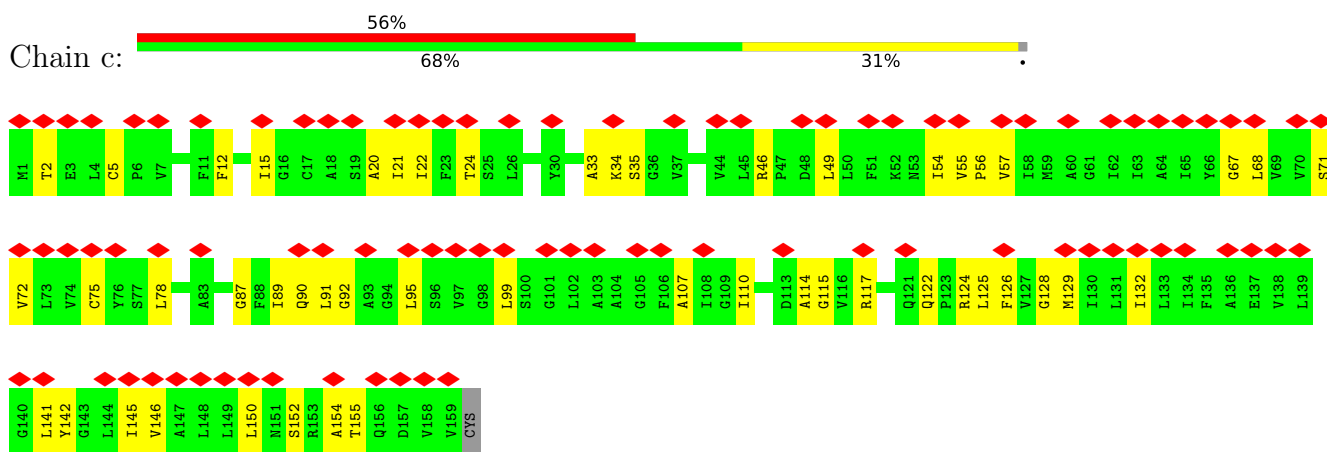

• Molecule 14: V-type proton ATPase subunit e

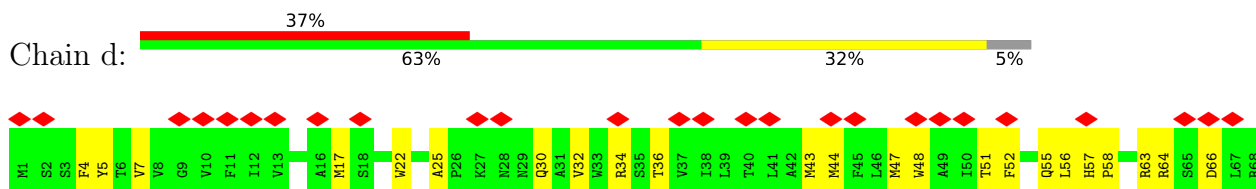



## 4 Experimental information

Property	Value	Source
EM reconstruction method	SINGLE PARTICLE	Depositor
Imposed symmetry	POINT, C1	Depositor
Number of particles used	85109	Depositor
Resolution determination method	FSC 0.143 CUT-OFF	Depositor
CTF correction method	PHASE FLIPPING AND AMPLITUDE CORRECTION	Depositor
Microscope	TFS KRIOS	Depositor
Voltage (kV)	300	Depositor
Electron dose ( $e^-/\text{\AA}^2$ )	50	Depositor
Minimum defocus (nm)	500	Depositor
Maximum defocus (nm)	2500	Depositor
Magnification	Not provided	
Image detector	GATAN K2 SUMMIT (4k x 4k)	Depositor
Maximum map value	0.098	Depositor
Minimum map value	-0.038	Depositor
Average map value	0.000	Depositor
Map value standard deviation	0.005	Depositor
Recommended contour level	0.02	Depositor
Map size ( $\text{\AA}$ )	432.00003, 432.00003, 432.00003	wwPDB
Map dimensions	400, 400, 400	wwPDB
Map angles ( $^\circ$ )	90.0, 90.0, 90.0	wwPDB
Pixel spacing ( $\text{\AA}$ )	1.08, 1.08, 1.08	Depositor

## 5 Model quality [i](#)

### 5.1 Standard geometry [i](#)

The Z score for a bond length (or angle) is the number of standard deviations the observed value is removed from the expected value. A bond length (or angle) with  $|Z| > 5$  is considered an outlier worth inspection. RMSZ is the root-mean-square of all Z scores of the bond lengths (or angles).

Mol	Chain	Bond lengths		Bond angles	
		RMSZ	# Z  >5	RMSZ	# Z  >5
1	A	0.18	0/4685	0.31	0/6351
1	C	0.18	0/4685	0.33	0/6351
1	E	0.18	0/4685	0.31	0/6351
2	B	0.19	0/3776	0.31	0/5114
2	D	0.19	0/3750	0.31	0/5078
2	F	0.19	0/3768	0.31	0/5102
3	G	0.16	0/1817	0.31	0/2436
3	I	0.15	0/1817	0.30	0/2436
3	K	0.15	0/1817	0.29	0/2436
4	H	0.13	0/876	0.31	0/1164
4	J	0.11	0/876	0.26	0/1164
4	L	0.12	0/876	0.28	0/1164
5	M	0.13	0/1775	0.32	0/2381
6	N	0.10	0/944	0.27	0/1277
7	O	0.13	0/3184	0.35	0/4314
8	P	0.12	0/3723	0.33	0/5028
9	Q	0.13	0/6221	0.35	0/8421
10	S	0.11	0/2852	0.32	0/3870
11	T	0.13	0/1523	0.37	0/2068
12	U	0.16	0/1162	0.35	0/1575
13	V	0.15	0/1158	0.35	0/1574
13	W	0.16	0/1158	0.40	0/1574
13	X	0.15	0/1158	0.38	0/1574
13	Y	0.15	0/1164	0.38	0/1582
13	Z	0.17	0/1158	0.38	0/1574
13	a	0.15	0/1158	0.35	0/1574
13	b	0.16	0/1164	0.37	0/1582
13	c	0.16	0/1158	0.35	0/1574
14	d	0.13	0/569	0.38	0/776
15	e	0.09	0/409	0.29	0/557
16	f	0.09	0/600	0.30	0/822
All	All	0.16	0/65666	0.33	0/88844

There are no bond length outliers.

There are no bond angle outliers.

There are no chirality outliers.

There are no planarity outliers.

## 5.2 Too-close contacts [i](#)

In the following table, the Non-H and H(model) columns list the number of non-hydrogen atoms and hydrogen atoms in the chain respectively. The H(added) column lists the number of hydrogen atoms added and optimized by MolProbity. The Clashes column lists the number of clashes within the asymmetric unit, whereas Symm-Clashes lists symmetry-related clashes.

Mol	Chain	Non-H	H(model)	H(added)	Clashes	Symm-Clashes
1	A	4586	0	4525	54	0
1	C	4586	0	4525	53	0
1	E	4586	0	4525	40	0
2	B	3706	0	3700	38	0
2	D	3681	0	3681	41	0
2	F	3699	0	3693	32	0
3	G	1802	0	1873	15	0
3	I	1802	0	1873	30	0
3	K	1802	0	1873	20	0
4	H	871	0	921	17	0
4	J	871	0	921	8	0
4	L	871	0	921	13	0
5	M	1756	0	1802	25	0
6	N	928	0	926	14	0
7	O	3121	0	3155	79	0
8	P	3665	0	3771	90	0
9	Q	6069	0	6041	206	0
10	S	2793	0	2677	52	0
11	T	1492	0	1562	45	0
12	U	1139	0	1194	44	0
13	V	1140	0	1214	38	0
13	W	1140	0	1214	44	0
13	X	1140	0	1214	36	0
13	Y	1146	0	1219	33	0
13	Z	1140	0	1214	45	0
13	a	1140	0	1214	27	0
13	b	1146	0	1219	42	0
13	c	1140	0	1214	44	0
14	d	553	0	581	23	0
15	e	403	0	432	7	0
16	f	583	0	576	7	0

*Continued on next page...*

*Continued from previous page...*

Mol	Chain	Non-H	H(model)	H(added)	Clashes	Symm-Clashes
All	All	64497	0	65470	1135	0

The all-atom clashscore is defined as the number of clashes found per 1000 atoms (including hydrogen atoms). The all-atom clashscore for this structure is 9.

The worst 5 of 1135 close contacts within the same asymmetric unit are listed below, sorted by their clash magnitude.

Atom-1	Atom-2	Interatomic distance (Å)	Clash overlap (Å)
13:b:153:ARG:NH1	13:c:75:CYS:O	1.95	1.00
1:C:269:LEU:O	1:C:273:SER:OG	1.89	0.91
9:Q:90:LYS:O	9:Q:99:TYR:OH	1.87	0.91
3:I:79:THR:O	3:I:83:LYS:N	2.04	0.89
13:V:46:ARG:NH1	13:V:47:PRO:O	2.04	0.89

There are no symmetry-related clashes.

## 5.3 Torsion angles [i](#)

### 5.3.1 Protein backbone [i](#)

In the following table, the Percentiles column shows the percent Ramachandran outliers of the chain as a percentile score with respect to all PDB entries followed by that with respect to all EM entries.

The Analysed column shows the number of residues for which the backbone conformation was analysed, and the total number of residues.

Mol	Chain	Analysed	Favoured	Allowed	Outliers	Percentiles	
1	A	592/617 (96%)	551 (93%)	41 (7%)	0	100	100
1	C	592/617 (96%)	552 (93%)	40 (7%)	0	100	100
1	E	592/617 (96%)	552 (93%)	40 (7%)	0	100	100
2	B	467/517 (90%)	434 (93%)	33 (7%)	0	100	100
2	D	464/517 (90%)	435 (94%)	29 (6%)	0	100	100
2	F	436/517 (84%)	413 (95%)	23 (5%)	0	100	100
3	G	223/233 (96%)	214 (96%)	9 (4%)	0	100	100
3	I	223/233 (96%)	212 (95%)	11 (5%)	0	100	100
3	K	223/233 (96%)	217 (97%)	6 (3%)	0	100	100

*Continued on next page...*

Continued from previous page...

Mol	Chain	Analysed	Favoured	Allowed	Outliers	Percentiles	
4	H	109/122 (89%)	105 (96%)	4 (4%)	0	100	100
4	J	109/122 (89%)	106 (97%)	3 (3%)	0	100	100
4	L	109/122 (89%)	108 (99%)	1 (1%)	0	100	100
5	M	216/256 (84%)	203 (94%)	13 (6%)	0	100	100
6	N	113/118 (96%)	103 (91%)	10 (9%)	0	100	100
7	O	390/392 (100%)	349 (90%)	41 (10%)	0	100	100
8	P	448/469 (96%)	421 (94%)	27 (6%)	0	100	100
9	Q	741/840 (88%)	689 (93%)	52 (7%)	0	100	100
10	S	342/345 (99%)	331 (97%)	11 (3%)	0	100	100
11	T	198/213 (93%)	191 (96%)	7 (4%)	0	100	100
12	U	155/164 (94%)	150 (97%)	5 (3%)	0	100	100
13	V	157/160 (98%)	153 (98%)	4 (2%)	0	100	100
13	W	157/160 (98%)	150 (96%)	7 (4%)	0	100	100
13	X	157/160 (98%)	151 (96%)	6 (4%)	0	100	100
13	Y	158/160 (99%)	153 (97%)	5 (3%)	0	100	100
13	Z	157/160 (98%)	154 (98%)	3 (2%)	0	100	100
13	a	157/160 (98%)	148 (94%)	9 (6%)	0	100	100
13	b	158/160 (99%)	151 (96%)	7 (4%)	0	100	100
13	c	157/160 (98%)	151 (96%)	6 (4%)	0	100	100
14	d	67/73 (92%)	61 (91%)	6 (9%)	0	100	100
15	e	50/265 (19%)	46 (92%)	4 (8%)	0	100	100
16	f	74/85 (87%)	68 (92%)	6 (8%)	0	100	100
All	All	8191/8967 (91%)	7722 (94%)	469 (6%)	0	100	100

There are no Ramachandran outliers to report.

### 5.3.2 Protein sidechains [i](#)

There are no protein residues with a non-rotameric sidechain to report in this entry.

### 5.3.3 RNA [i](#)

There are no RNA molecules in this entry.

## 5.4 Non-standard residues in protein, DNA, RNA chains [i](#)

There are no non-standard protein/DNA/RNA residues in this entry.

## 5.5 Carbohydrates [i](#)

There are no oligosaccharides in this entry.

## 5.6 Ligand geometry [i](#)

There are no ligands in this entry.

## 5.7 Other polymers [i](#)

There are no such residues in this entry.

## 5.8 Polymer linkage issues [i](#)

There are no chain breaks in this entry.

## 6 Map visualisation [i](#)

This section contains visualisations of the EMDB entry EMD-31538. These allow visual inspection of the internal detail of the map and identification of artifacts.

No raw map or half-maps were deposited for this entry and therefore no images, graphs, etc. pertaining to the raw map can be shown.

### 6.1 Orthogonal projections [i](#)

#### 6.1.1 Primary map

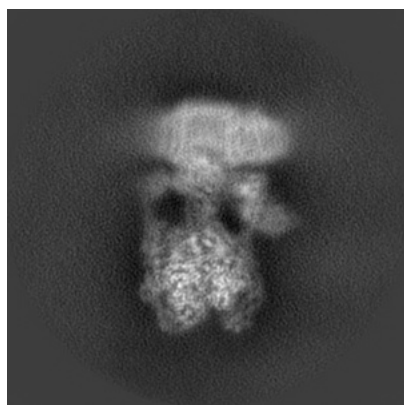

X

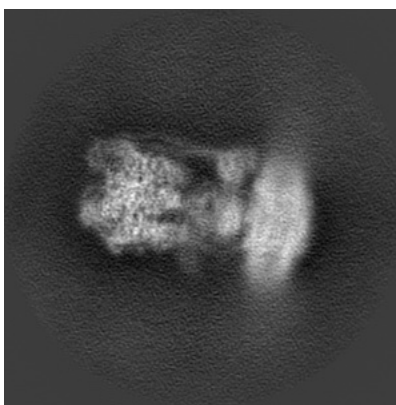

Y

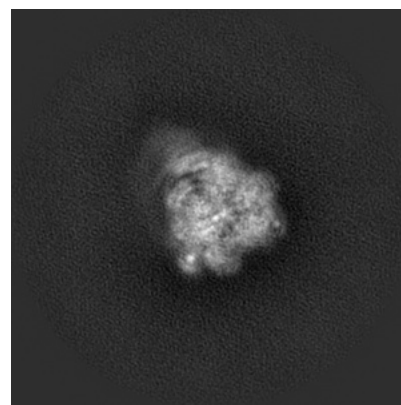

Z

The images above show the map projected in three orthogonal directions.

### 6.2 Central slices [i](#)

#### 6.2.1 Primary map

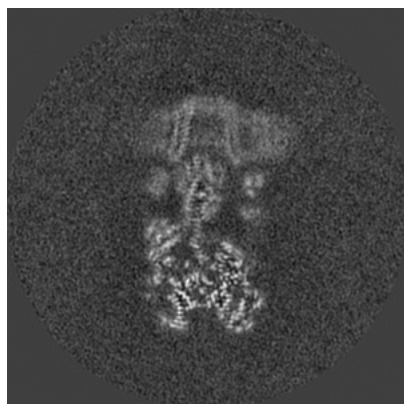

X Index: 200

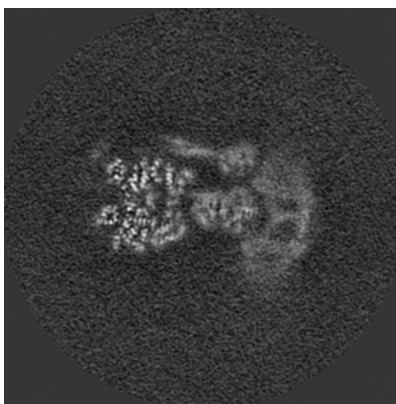

Y Index: 200

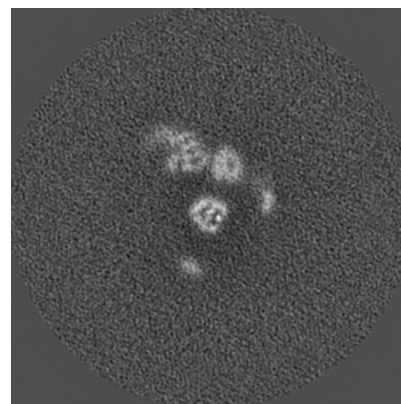

Z Index: 200

The images above show central slices of the map in three orthogonal directions.

## 6.3 Largest variance slices [i](#)

### 6.3.1 Primary map

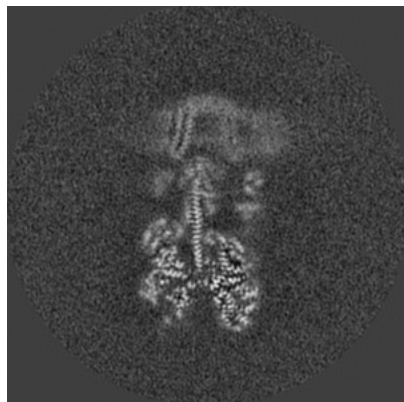

X Index: 205

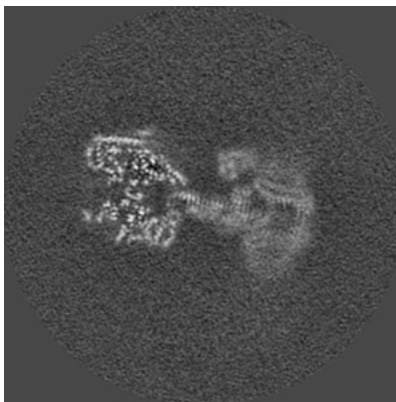

Y Index: 183

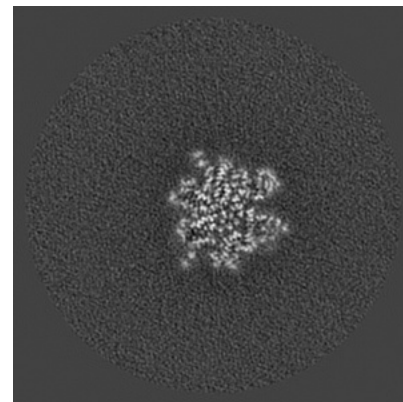

Z Index: 127

The images above show the largest variance slices of the map in three orthogonal directions.

## 6.4 Orthogonal standard-deviation projections (False-color) [i](#)

### 6.4.1 Primary map

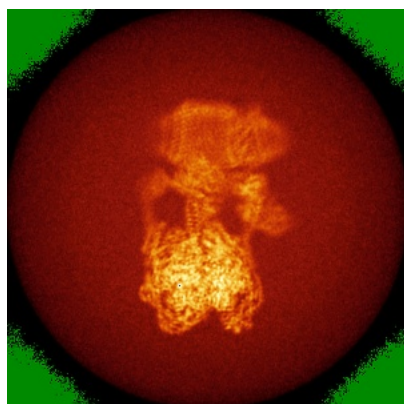

X

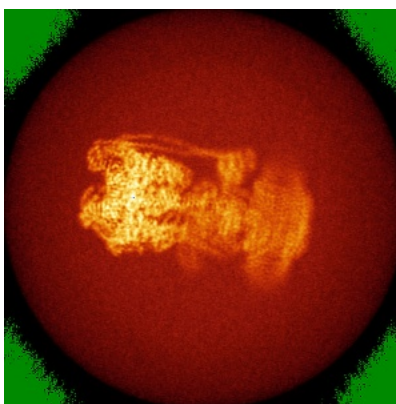

Y

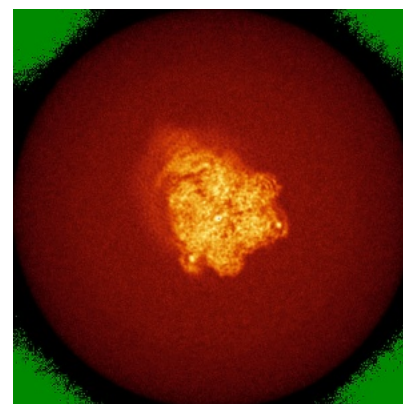

Z

The images above show the map standard deviation projections with false color in three orthogonal directions. Minimum values are shown in green, max in blue, and dark to light orange shades represent small to large values respectively.

## 6.5 Orthogonal surface views [i](#)

### 6.5.1 Primary map

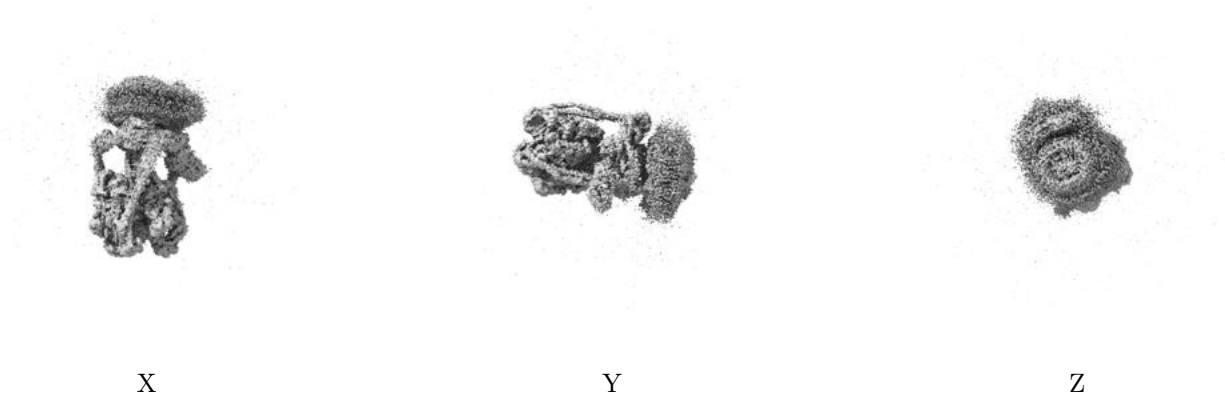

The images above show the 3D surface view of the map at the recommended contour level 0.02. These images, in conjunction with the slice images, may facilitate assessment of whether an appropriate contour level has been provided.

## 6.6 Mask visualisation [i](#)

This section was not generated. No masks/segmentation were deposited.

## 7 Map analysis [i](#)

This section contains the results of statistical analysis of the map.

### 7.1 Map-value distribution [i](#)

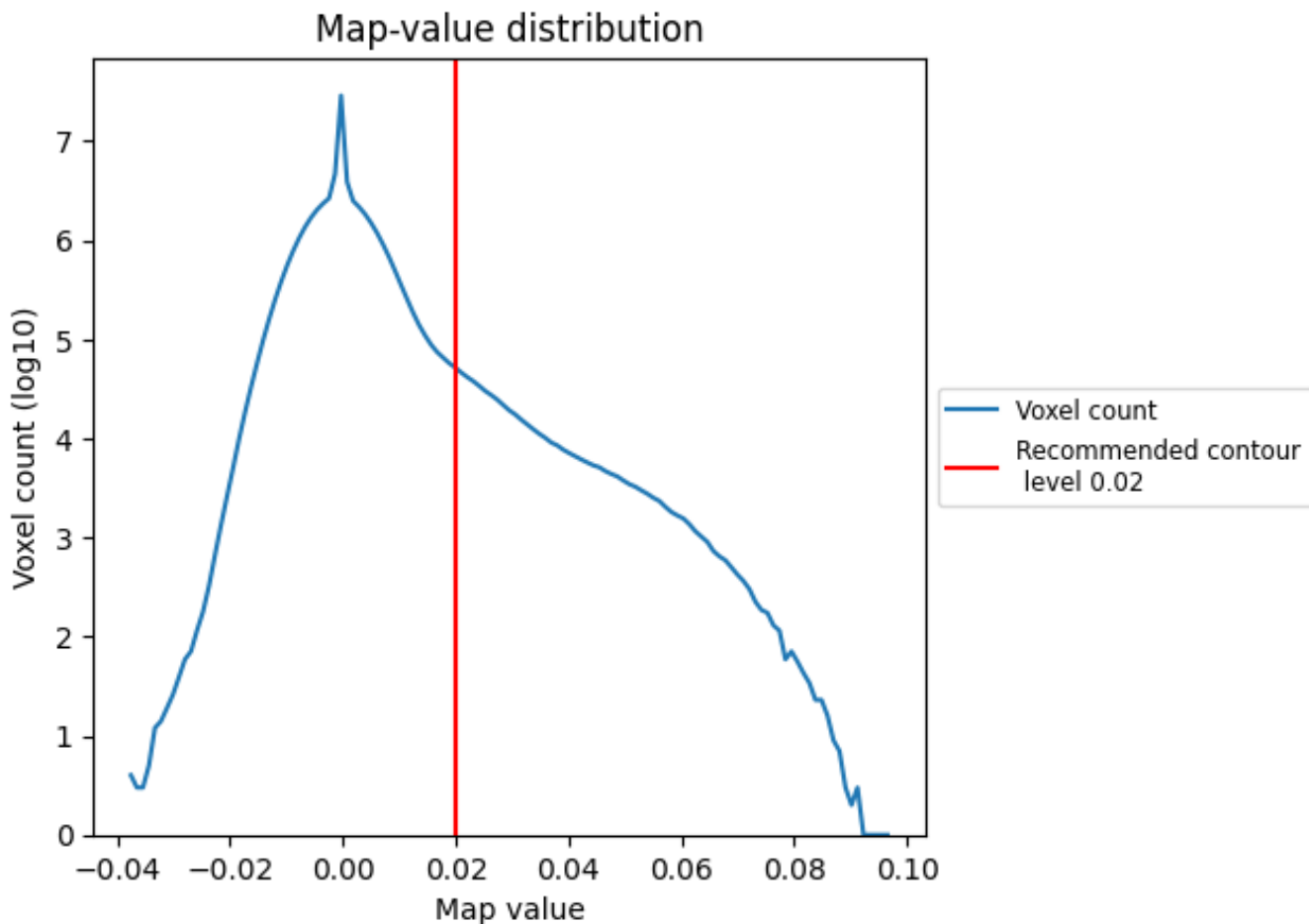

The map-value distribution is plotted in 128 intervals along the x-axis. The y-axis is logarithmic. A spike in this graph at zero usually indicates that the volume has been masked.

## 7.2 Volume estimate [\(i\)](#)

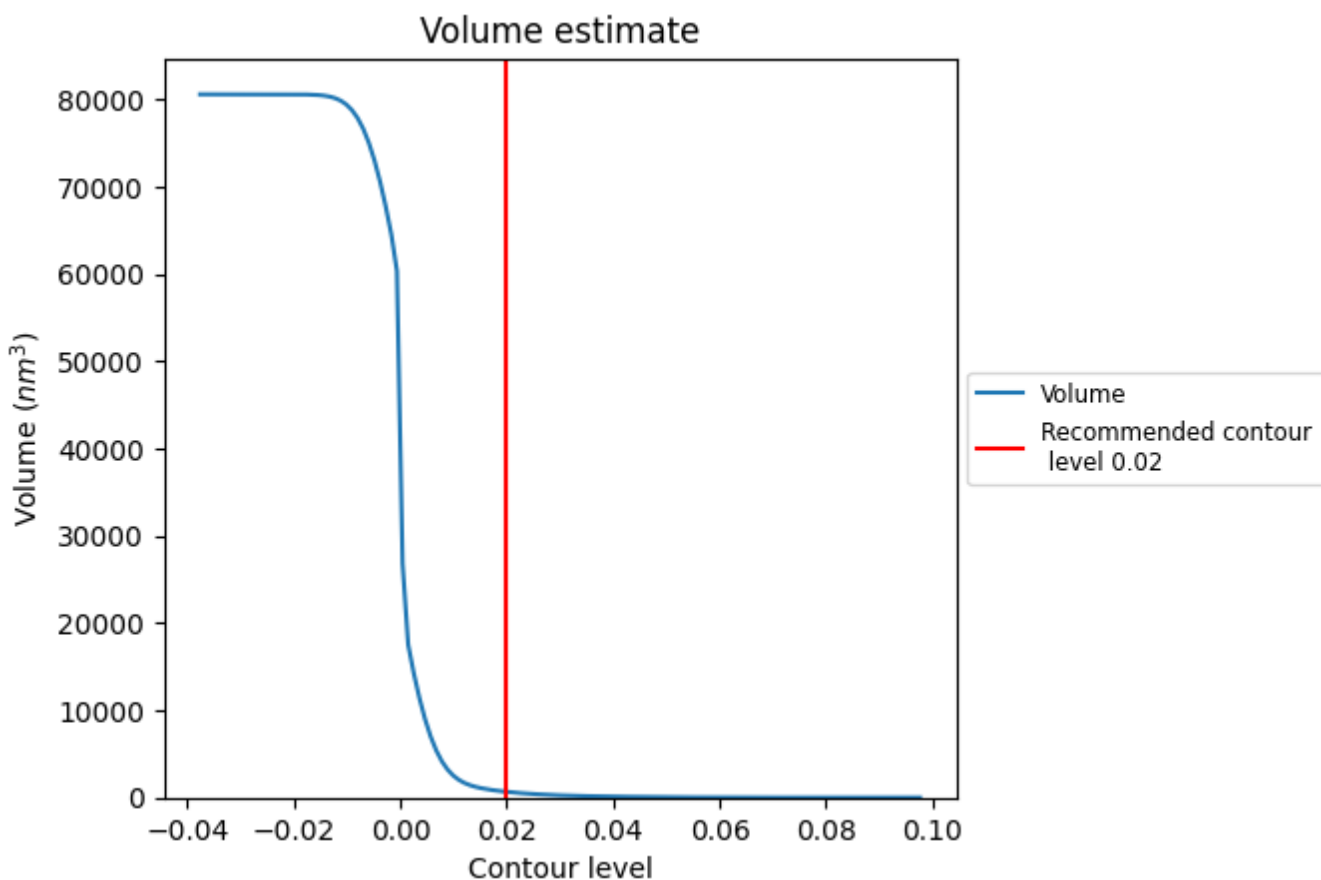

The volume at the recommended contour level is 660  $\text{nm}^3$ ; this corresponds to an approximate mass of 597 kDa.

The volume estimate graph shows how the enclosed volume varies with the contour level. The recommended contour level is shown as a vertical line and the intersection between the line and the curve gives the volume of the enclosed surface at the given level.

### 7.3 Rotationally averaged power spectrum [i](#)

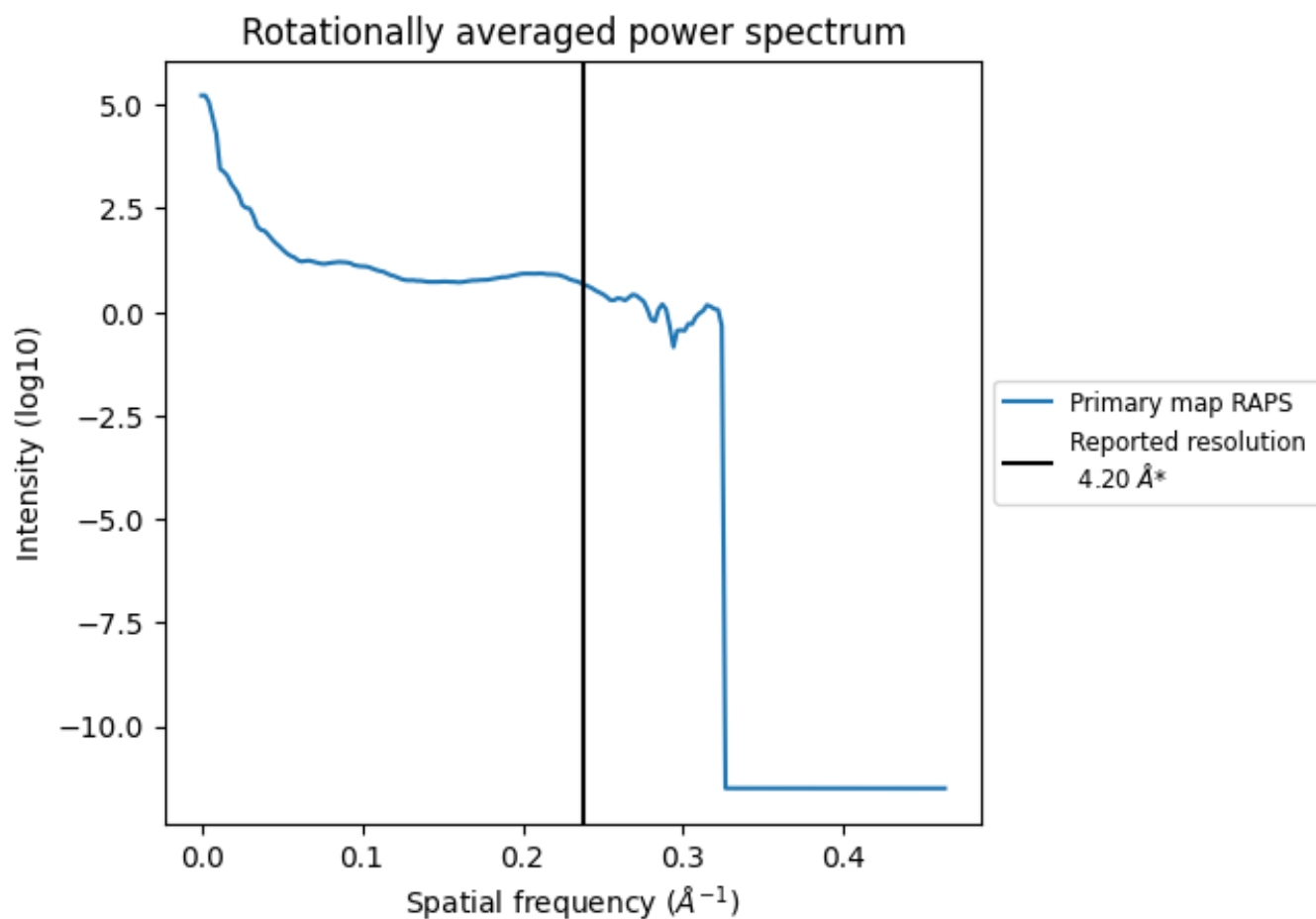

\*Reported resolution corresponds to spatial frequency of 0.238 Å<sup>-1</sup>

## 8 Fourier-Shell correlation [i](#)

Fourier-Shell Correlation (FSC) is the most commonly used method to estimate the resolution of single-particle and subtomogram-averaged maps. The shape of the curve depends on the imposed symmetry, mask and whether or not the two 3D reconstructions used were processed from a common reference. The reported resolution is shown as a black line. A curve is displayed for the half-bit criterion in addition to lines showing the 0.143 gold standard cut-off and 0.5 cut-off.

### 8.1 FSC [i](#)

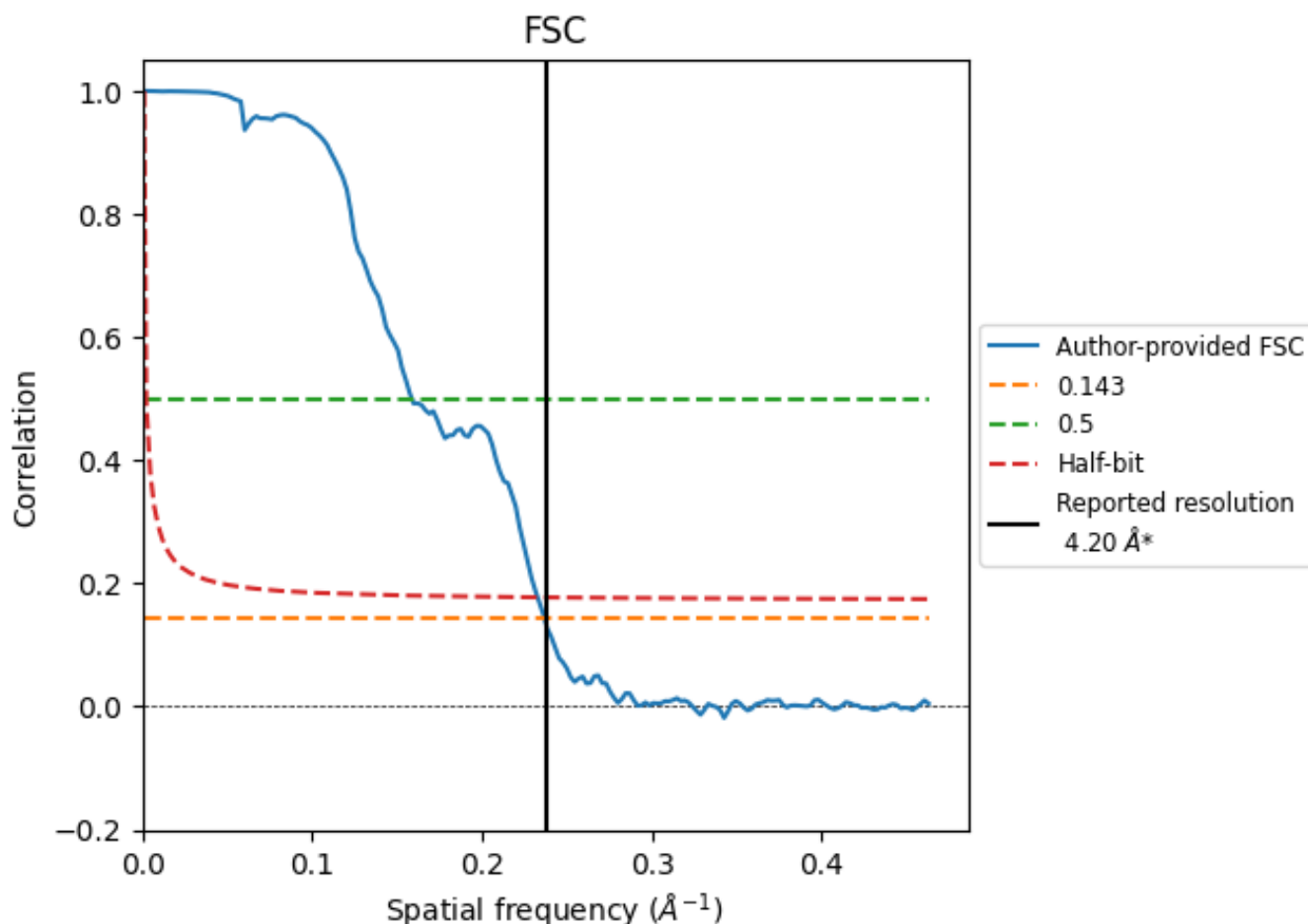

\*Reported resolution corresponds to spatial frequency of 0.238 Å<sup>-1</sup>

## 8.2 Resolution estimates [i](#)

Resolution estimate (Å)	Estimation criterion (FSC cut-off)		
	0.143	0.5	Half-bit
Reported by author	4.20	-	-
Author-provided FSC curve	4.22	6.30	4.30
Unmasked-calculated*	-	-	-

\*Resolution estimate based on FSC curve calculated by comparison of deposited half-maps.

## 9 Map-model fit [i](#)

This section contains information regarding the fit between EMDB map EMD-31538 and PDB model 7FDA. Per-residue inclusion information can be found in section 3 on page 9.

### 9.1 Map-model overlay [i](#)

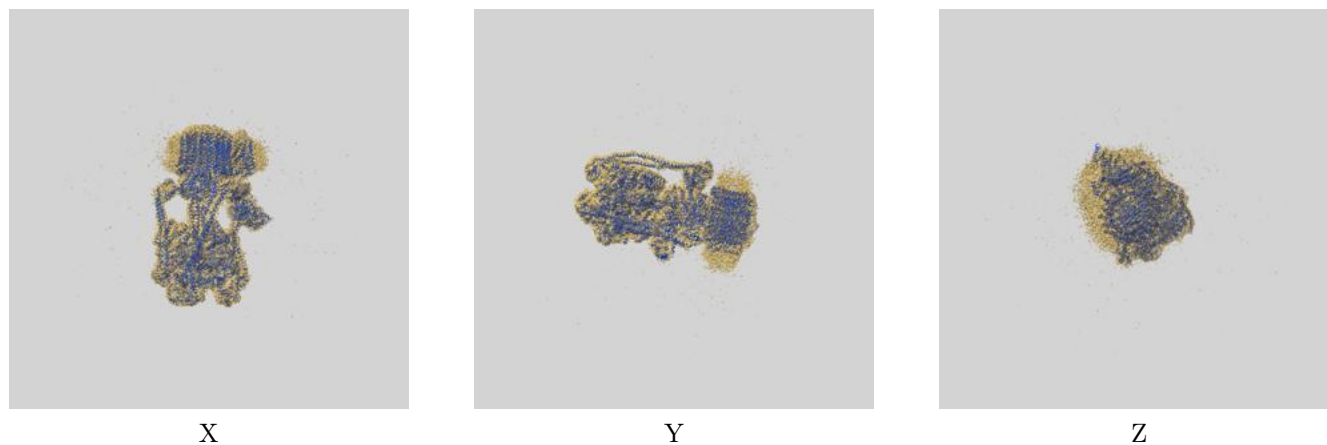

The images above show the 3D surface view of the map at the recommended contour level 0.02 at 50% transparency in yellow overlaid with a ribbon representation of the model coloured in blue. These images allow for the visual assessment of the quality of fit between the atomic model and the map.

## 9.2 Q-score mapped to coordinate model [i](#)

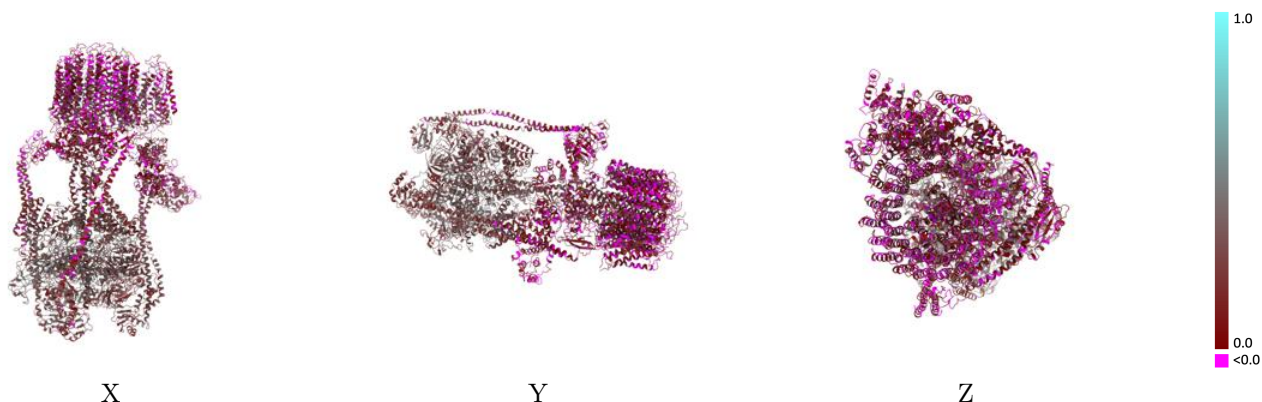

The images above show the model with each residue coloured according to its Q-score. This shows their resolvability in the map with higher Q-score values reflecting better resolvability. Please note: Q-score is calculating the resolvability of atoms, and thus high values are only expected at resolutions at which atoms can be resolved. Low Q-score values may therefore be expected for many entries.

## 9.3 Atom inclusion mapped to coordinate model [i](#)

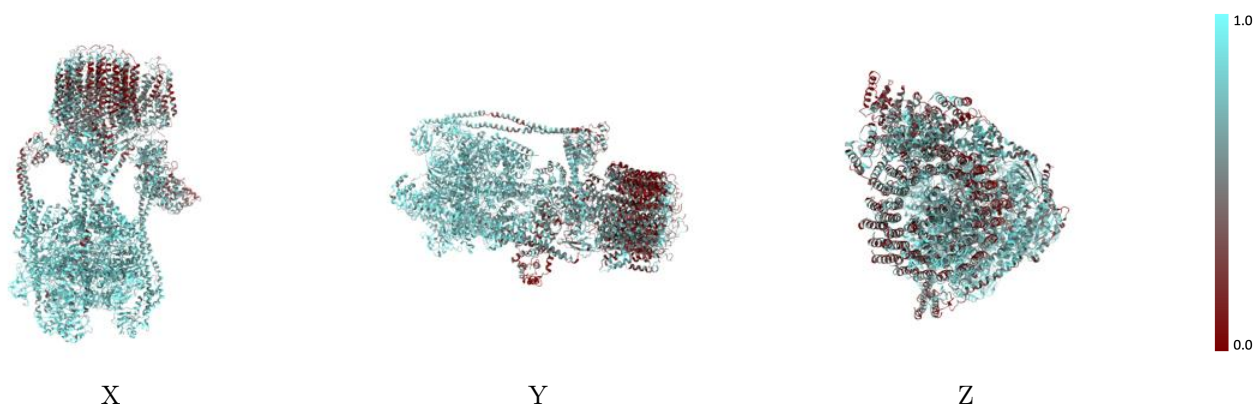

The images above show the model with each residue coloured according to its atom inclusion. This shows to what extent they are inside the map at the recommended contour level (0.02).



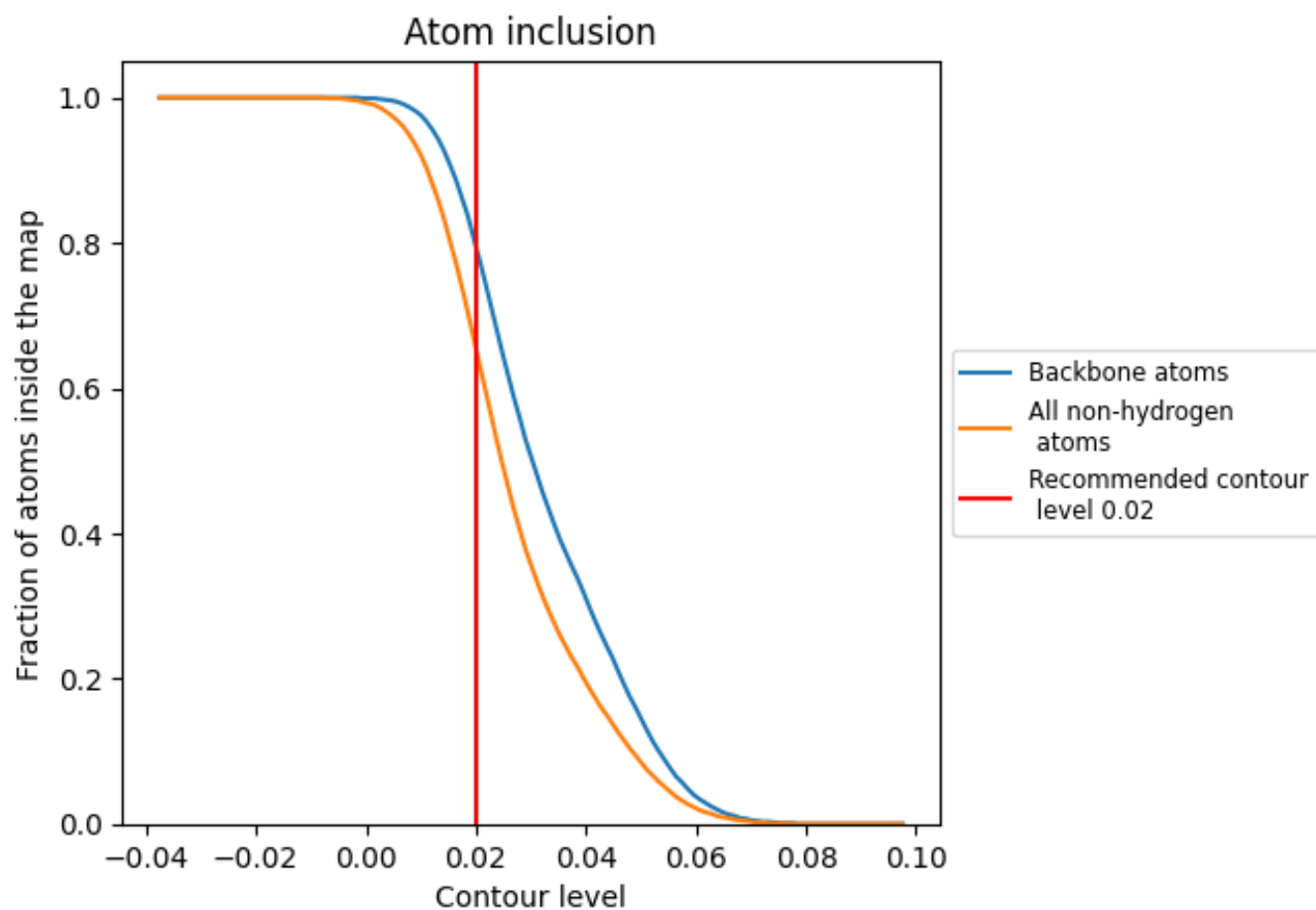



























































## 9.4 Atom inclusion [i](#)



At the recommended contour level, 80% of all backbone atoms, 66% of all non-hydrogen atoms, are inside the map.

## 9.5 Map-model fit summary

The table lists the average atom inclusion at the recommended contour level (0.02) and Q-score for the entire model and for each chain.

Chain	Atom inclusion	Q-score
All	 0.6550	 0.2050
A	 0.8520	 0.3560
B	 0.8050	 0.3380
C	 0.7930	 0.2830
D	 0.7990	 0.3130
E	 0.8130	 0.3260
F	 0.8290	 0.3660
G	 0.7410	 0.2400
H	 0.6300	 0.1830
I	 0.7320	 0.2140
J	 0.6140	 0.1350
K	 0.7240	 0.2210
L	 0.6760	 0.1900
M	 0.7450	 0.2590
N	 0.7280	 0.1700
O	 0.5390	 0.0840
P	 0.4780	 0.1030
Q	 0.5940	 0.1180
S	 0.5600	 0.1280
T	 0.4630	 0.0710
U	 0.5900	 0.1140
V	 0.4960	 0.0870
W	 0.3460	 0.0600
X	 0.3160	 0.0540
Y	 0.3590	 0.0620
Z	 0.5150	 0.1120
a	 0.4730	 0.0960
b	 0.4230	 0.0870
c	 0.3850	 0.0550
d	 0.5010	 0.0950
e	 0.3550	 0.0900
f	 0.4050	 0.0460

