



Full wwPDB X-ray Structure Validation Report ⓘ

Mar 5, 2026 – 10:52 AM UTC

PDB ID : 2BEH / pdb_00002beh
Title : Crystal structure of antithrombin variant S137A/V317C/T401C with plasma latent antithrombin
Authors : Johnson, D.J.; Luis, S.A.; Huntington, J.A.
Deposited on : 2005-10-24
Resolution : 2.70 Å(reported)

This is a Full wwPDB X-ray Structure Validation Report for a publicly released PDB entry.

We welcome your comments at validation@mail.wwpdb.org

A user guide is available at

<https://www.wwpdb.org/validation/2017/XrayValidationReportHelp>

with specific help available everywhere you see the ⓘ symbol.

The types of validation reports are described at

<http://www.wwpdb.org/validation/2017/FAQs#types>.

The following versions of software and data (see [references ⓘ](#)) were used in the production of this report:

MolProbity : 4-5-2 with Phenix2.0
Mogul : 2022.3.0, CSD as543be (2022)
Xtriage (Phenix) : 2.0
EDS : 3.0
Percentile statistics : 20250101.v01 (using entries in the PDB archive January 1st 2025)
CCP4 : 9.0.010 (Gargrove)
Density-Fitness : 1.0.12
Ideal geometry (proteins) : Engh & Huber (2001)
Ideal geometry (DNA, RNA) : Parkinson et al. (1996)
Validation Pipeline (wwPDB-VP) : 2.49

1 Overall quality at a glance

The following experimental techniques were used to determine the structure:

X-RAY DIFFRACTION

The reported resolution of this entry is 2.70 Å.

Percentile scores (ranging between 0-100) for global validation metrics of the entry are shown in the following graphic. The table shows the number of entries on which the scores are based.

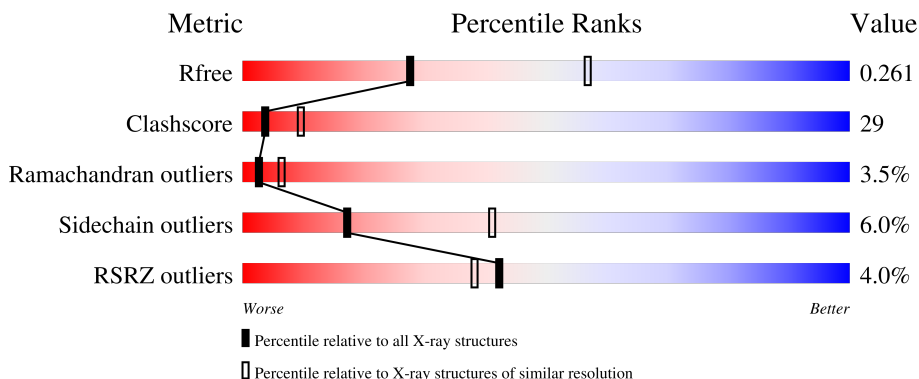

Metric	Whole archive (#Entries)	Similar resolution (#Entries, resolution range(Å))
R_{free}	180053	3538 (2.70-2.70)
Clashscore	190562	3843 (2.70-2.70)
Ramachandran outliers	187476	3778 (2.70-2.70)
Sidechain outliers	187428	3778 (2.70-2.70)
RSRZ outliers	180081	3538 (2.70-2.70)

The table below summarises the geometric issues observed across the polymeric chains and their fit to the electron density. The red, orange, yellow and green segments of the lower bar indicate the fraction of residues that contain outliers for ≥ 3 , 2, 1 and 0 types of geometric quality criteria respectively. A grey segment represents the fraction of residues that are not modelled. The numeric value for each fraction is indicated below the corresponding segment, with a dot representing fractions $\leq 5\%$. The upper red bar (where present) indicates the fraction of residues that have poor fit to the electron density. The numeric value is given above the bar.

Mol	Chain	Length	Quality of chain
1	I	432	
2	L	432	
3	A	2	
3	C	2	
4	B	3	

The following table lists non-polymeric compounds, carbohydrate monomers and non-standard residues in protein, DNA, RNA chains that are outliers for geometric or electron-density-fit criteria:

Mol	Type	Chain	Res	Chirality	Geometry	Clashes	Electron density
3	NAG	A	1	X	-	-	-
6	GOL	I	901	-	-	X	-

2 Entry composition [i](#)

There are 7 unique types of molecules in this entry. The entry contains 6377 atoms, of which 0 are hydrogens and 0 are deuteriums.

In the tables below, the ZeroOcc column contains the number of atoms modelled with zero occupancy, the AltConf column contains the number of residues with at least one atom in alternate conformation and the Trace column contains the number of residues modelled with at most 2 atoms.

- Molecule 1 is a protein called Antithrombin-III.

Mol	Chain	Residues	Atoms					ZeroOcc	AltConf	Trace
			Total	C	N	O	S			
1	I	413	3198	2050	529	601	18	0	0	0

There are 3 discrepancies between the modelled and reference sequences:

Chain	Residue	Modelled	Actual	Comment	Reference
I	137	ALA	SER	engineered mutation	UNP P01008
I	317	CYS	VAL	engineered mutation	UNP P01008
I	401	CYS	THR	engineered mutation	UNP P01008

- Molecule 2 is a protein called Antithrombin-III.

Mol	Chain	Residues	Atoms					ZeroOcc	AltConf	Trace
			Total	C	N	O	S			
2	L	403	3033	1944	495	577	17	0	0	0

- Molecule 3 is an oligosaccharide called 2-acetamido-2-deoxy-beta-D-glucopyranose-(1-4)-2-acetamido-2-deoxy-beta-D-glucopyranose.



Mol	Chain	Residues	Atoms				ZeroOcc	AltConf	Trace
			Total	C	N	O			
3	A	2	28	16	2	10	0	0	0
3	C	2	28	16	2	10	0	0	0

- Molecule 4 is an oligosaccharide called alpha-D-mannopyranose-(1-4)-2-acetamido-2-deoxy-beta-D-glucopyranose-(1-4)-2-acetamido-2-deoxy-beta-D-glucopyranose.

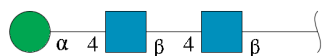

Mol	Chain	Residues	Atoms				ZeroOcc	AltConf	Trace
			Total	C	N	O			
4	B	3	39	22	2	15	0	0	0

- Molecule 5 is 2-acetamido-2-deoxy-beta-D-glucopyranose (CCD ID: NAG) (formula: $C_8H_{15}NO_6$).



Mol	Chain	Residues	Atoms				ZeroOcc	AltConf
			Total	C	N	O		
5	I	1	14	8	1	5	0	0
5	L	1	14	8	1	5	0	0

- Molecule 6 is GLYCEROL (CCD ID: GOL) (formula: $C_3H_8O_3$).



Mol	Chain	Residues	Atoms	ZeroOcc	AltConf
6	I	1	Total C O 6 3 3	0	0

- Molecule 7 is water.

Mol	Chain	Residues	Atoms	ZeroOcc	AltConf
7	I	12	Total O 12 12	0	0
7	L	5	Total O 5 5	0	0

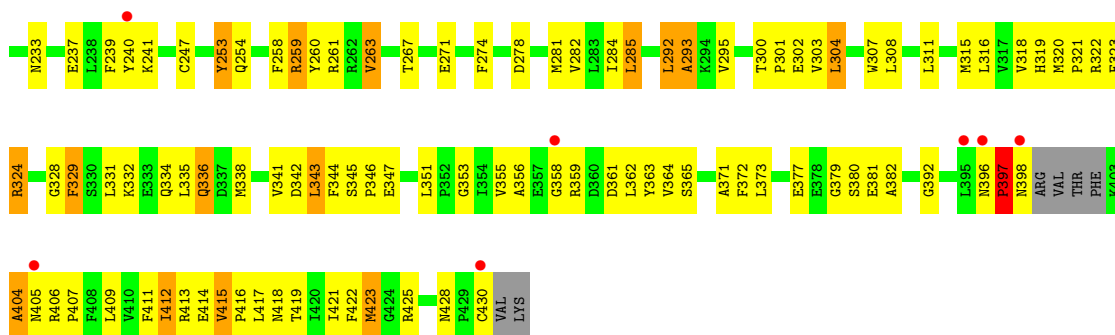

- Molecule 3: 2-acetamido-2-deoxy-beta-D-glucopyranose-(1-4)-2-acetamido-2-deoxy-beta-D-glucopyranose

Chain A:  100%

MAG1
MAG2

- Molecule 3: 2-acetamido-2-deoxy-beta-D-glucopyranose-(1-4)-2-acetamido-2-deoxy-beta-D-glucopyranose

Chain C:  100%

MAG1
MAG2

- Molecule 4: alpha-D-mannopyranose-(1-4)-2-acetamido-2-deoxy-beta-D-glucopyranose-(1-4)-2-acetamido-2-deoxy-beta-D-glucopyranose

Chain B:  33% 67%

MAG1
MAG2
MANS

4 Data and refinement statistics

Property	Value	Source
Space group	P 1 21 1	Depositor
Cell constants a, b, c, α , β , γ	68.07Å 97.27Å 87.39Å 90.00° 105.03° 90.00°	Depositor
Resolution (Å)	39.10 – 2.70 39.10 – 2.70	Depositor EDS
% Data completeness (in resolution range)	99.4 (39.10-2.70) 99.5 (39.10-2.70)	Depositor EDS
R_{merge}	(Not available)	Depositor
R_{sym}	(Not available)	Depositor
$\langle I/\sigma(I) \rangle$ ¹	2.19 (at 2.69Å)	Xtrriage
Refinement program	CNS 1.0	Depositor
R, R_{free}	0.219 , 0.265 0.219 , 0.261	Depositor DCC
R_{free} test set	1520 reflections (5.03%)	wwPDB-VP
Wilson B-factor (Å ²)	64.3	Xtrriage
Anisotropy	0.467	Xtrriage
Bulk solvent k_{sol} (e/Å ³), B_{sol} (Å ²)	0.31 , 42.1	EDS
L-test for twinning ²	$\langle L \rangle = 0.49$, $\langle L^2 \rangle = 0.32$	Xtrriage
Estimated twinning fraction	No twinning to report.	Xtrriage
F_o, F_c correlation	0.94	EDS
Total number of atoms	6377	wwPDB-VP
Average B, all atoms (Å ²)	62.0	wwPDB-VP

Xtrriage's analysis on translational NCS is as follows: *The largest off-origin peak in the Patterson function is 4.86% of the height of the origin peak. No significant pseudotranslation is detected.*

¹Intensities estimated from amplitudes.

²Theoretical values of $\langle |L| \rangle$, $\langle L^2 \rangle$ for acentric reflections are 0.5, 0.333 respectively for untwinned datasets, and 0.375, 0.2 for perfectly twinned datasets.

5 Model quality i

5.1 Standard geometry i

Bond lengths and bond angles in the following residue types are not validated in this section: MAN, GOL, NAG

The Z score for a bond length (or angle) is the number of standard deviations the observed value is removed from the expected value. A bond length (or angle) with $|Z| > 5$ is considered an outlier worth inspection. RMSZ is the root-mean-square of all Z scores of the bond lengths (or angles).

Mol	Chain	Bond lengths		Bond angles	
		RMSZ	# Z >5	RMSZ	# Z >5
1	I	0.52	0/3264	1.03	17/4425 (0.4%)
2	L	0.53	0/3094	1.01	15/4212 (0.4%)
All	All	0.52	0/6358	1.02	32/8637 (0.4%)

There are no bond length outliers.

All (32) bond angle outliers are listed below:

Mol	Chain	Res	Type	Atoms	Z	Observed(°)	Ideal(°)
1	I	42	GLU	N-CA-C	14.49	125.16	108.49
1	I	43	ALA	N-CA-C	-9.21	91.18	110.80
1	I	42	GLU	CA-C-O	8.51	126.31	120.19
2	L	88	ALA	N-CA-C	-6.93	103.81	111.36
2	L	322	ARG	N-CA-C	-6.71	97.60	108.41
2	L	96	ASN	CB-CA-C	-6.70	108.12	117.23
2	L	136	LYS	N-CA-C	6.62	124.90	110.80
1	I	406	ARG	N-CA-C	-6.47	102.40	108.22
1	I	226	LYS	N-CA-C	-6.44	104.12	112.23
1	I	90	THR	N-CA-C	-6.39	104.24	111.14
2	L	96	ASN	N-CA-C	6.23	119.07	108.67
1	I	329	PHE	N-CA-C	5.88	119.06	109.59
2	L	216	VAL	N-CA-C	5.88	116.59	108.12
2	L	135	ASN	N-CA-C	5.85	117.94	108.41
1	I	341	VAL	N-CA-C	5.82	116.82	111.81
2	L	259	ARG	N-CA-C	-5.80	101.26	109.96
2	L	134	ALA	N-CA-C	-5.71	104.72	112.26
2	L	329	PHE	N-CA-C	5.62	116.69	108.14
1	I	124	ALA	N-CA-C	-5.59	105.09	111.07
1	I	412	ILE	N-CA-C	-5.54	98.46	107.28
1	I	275	LYS	N-CA-C	-5.43	102.58	110.24
2	L	226	LYS	N-CA-C	-5.40	105.50	111.71

Continued on next page...

Continued from previous page...

Mol	Chain	Res	Type	Atoms	Z	Observed(°)	Ideal(°)
1	I	157	THR	N-CA-C	-5.32	105.15	111.69
2	L	412	ILE	N-CA-C	-5.31	98.84	107.28
1	I	48	VAL	N-CA-C	-5.28	105.23	110.62
1	I	322	ARG	N-CA-C	-5.22	101.46	109.76
1	I	42	GLU	CB-CA-C	-5.14	107.11	114.87
1	I	414	GLU	N-CA-C	-5.11	100.19	108.41
2	L	138	SER	N-CA-C	-5.08	102.55	109.71
2	L	137	SER	N-CA-C	-5.07	106.18	112.47
2	L	336	GLN	N-CA-C	-5.04	105.69	111.14
1	I	259	ARG	N-CA-C	-5.04	102.19	109.59

There are no chirality outliers.

There are no planarity outliers.

5.2 Too-close contacts

In the following table, the Non-H and H(model) columns list the number of non-hydrogen atoms and hydrogen atoms in the chain respectively. The H(added) column lists the number of hydrogen atoms added and optimized by MolProbity. The Clashes column lists the number of clashes within the asymmetric unit, whereas Symm-Clashes lists symmetry-related clashes.

Mol	Chain	Non-H	H(model)	H(added)	Clashes	Symm-Clashes
1	I	3198	0	3088	173	0
2	L	3033	0	2846	182	0
3	A	28	0	25	6	0
3	C	28	0	25	4	0
4	B	39	0	34	6	0
5	I	14	0	13	0	0
5	L	14	0	13	0	0
6	I	6	0	8	8	0
7	I	12	0	0	0	0
7	L	5	0	0	1	0
All	All	6377	0	6052	359	0

The all-atom clashscore is defined as the number of clashes found per 1000 atoms (including hydrogen atoms). The all-atom clashscore for this structure is 29.

All (359) close contacts within the same asymmetric unit are listed below, sorted by their clash magnitude.

Atom-1	Atom-2	Interatomic distance (Å)	Clash overlap (Å)
1:I:281:MET:HE3	1:I:283:LEU:HD21	1.27	1.12
1:I:419:THR:HG23	6:I:901:GOL:H11	1.41	1.02
2:L:73:ASN:ND2	2:L:405:ASN:HA	1.75	1.00
2:L:292:LEU:HD23	2:L:407:PRO:HG2	1.44	0.99
2:L:73:ASN:HD22	2:L:405:ASN:HA	1.27	0.99
1:I:42:GLU:CB	1:I:44:THR:H	1.79	0.95
1:I:351:LEU:HB3	1:I:354:ILE:HD13	1.51	0.92
2:L:222:LYS:HG2	2:L:381:GLU:HG3	1.53	0.91
1:I:178:ASN:HB3	1:I:181:GLN:HB3	1.52	0.91
2:L:405:ASN:ND2	2:L:406:ARG:H	1.70	0.90
1:I:115:THR:HG22	1:I:117:ASP:H	1.36	0.89
1:I:146:LEU:HD13	1:I:215:LEU:HD13	1.56	0.86
1:I:355:VAL:HG13	1:I:362:LEU:HD22	1.58	0.84
2:L:356:ALA:HB2	3:C:1:NAG:H81	1.60	0.84
2:L:51:LEU:HD21	2:L:123:PHE:HA	1.60	0.83
2:L:258:PHE:HB2	2:L:316:LEU:HD21	1.60	0.83
2:L:15:ILE:HD12	2:L:16:PRO:HD2	1.61	0.83
2:L:404:ALA:HB2	2:L:428:ASN:HD22	1.45	0.81
4:B:1:NAG:H61	4:B:2:NAG:HN2	1.48	0.79
1:I:190:VAL:HB	1:I:201:VAL:HG21	1.65	0.78
2:L:19:PRO:HD2	2:L:117:ASP:HB3	1.65	0.77
2:L:132:ARG:O	2:L:133:LYS:HG3	1.84	0.77
1:I:302:GLU:CD	1:I:302:GLU:H	1.91	0.77
1:I:281:MET:CE	1:I:283:LEU:HD21	2.13	0.77
2:L:147:PHE:HB3	2:L:173:LEU:HD12	1.66	0.76
2:L:404:ALA:HB2	2:L:428:ASN:ND2	2.01	0.76
1:I:194:THR:HG21	1:I:198:ILE:HB	1.67	0.75
1:I:415:VAL:HB	1:I:416:PRO:HD3	1.69	0.74
1:I:190:VAL:O	1:I:194:THR:HG23	1.88	0.74
1:I:213:LEU:HB2	1:I:363:TYR:O	1.88	0.73
2:L:229:PHE:O	2:L:377:GLU:HB3	1.90	0.72
2:L:259:ARG:HD3	2:L:271:GLU:OE1	1.89	0.72
2:L:332:LYS:HG2	2:L:336:GLN:NE2	2.06	0.71
2:L:332:LYS:O	2:L:336:GLN:HG3	1.89	0.71
2:L:91:LYS:HE2	2:L:120:HIS:NE2	2.05	0.71
2:L:143:ALA:HB3	2:L:193:LYS:HG2	1.71	0.70
2:L:356:ALA:CB	3:C:1:NAG:H81	2.21	0.70
2:L:405:ASN:HD22	2:L:406:ARG:N	1.91	0.69
1:I:329:PHE:HB2	1:I:369:HIS:HB3	1.74	0.69
2:L:73:ASN:HD21	2:L:405:ASN:ND2	1.91	0.68
2:L:225:TRP:CD1	2:L:379:GLY:HA2	2.28	0.68
1:I:345:SER:O	1:I:349:SER:HB2	1.94	0.68

Continued on next page...

Continued from previous page...

Atom-1	Atom-2	Interatomic distance (Å)	Clash overlap (Å)
2:L:190:VAL:HG11	2:L:201:VAL:HG21	1.74	0.68
1:I:281:MET:HE1	1:I:320:MET:HE1	1.75	0.67
2:L:405:ASN:ND2	2:L:406:ARG:N	2.41	0.67
2:L:129:ARG:O	2:L:417:LEU:HD11	1.94	0.67
2:L:324:ARG:HG3	2:L:324:ARG:O	1.95	0.67
1:I:45:ASN:OD1	1:I:48:VAL:HG23	1.96	0.66
3:A:1:NAG:H83	3:A:1:NAG:O3	1.94	0.66
2:L:212:VAL:HG21	2:L:362:LEU:CD2	2.26	0.66
2:L:80:PRO:HG3	2:L:423:MET:HE2	1.78	0.65
2:L:124:ALA:HB2	2:L:165:VAL:HG13	1.76	0.65
1:I:389:VAL:CG1	2:L:285:LEU:HD11	2.27	0.65
1:I:115:THR:HG22	1:I:117:ASP:N	2.08	0.65
4:B:1:NAG:H61	4:B:2:NAG:N2	2.11	0.65
1:I:349:SER:O	1:I:350:LYS:HG3	1.96	0.65
2:L:46:ARG:O	2:L:50:GLU:HG3	1.97	0.65
1:I:346:PRO:HG3	1:I:363:TYR:CE2	2.32	0.64
2:L:358:GLY:C	2:L:359:ARG:HG3	2.21	0.64
1:I:115:THR:H	1:I:118:GLN:HE21	1.45	0.64
2:L:284:ILE:HB	2:L:409:LEU:HB2	1.80	0.64
1:I:202:ILE:HD13	1:I:207:ILE:HD11	1.80	0.64
1:I:286:PRO:HB3	1:I:295:VAL:HG21	1.80	0.64
1:I:319:HIS:HB2	1:I:403:LYS:HA	1.79	0.63
1:I:190:VAL:CB	1:I:201:VAL:HG21	2.27	0.63
1:I:19:PRO:C	1:I:21:CYS:H	2.05	0.63
2:L:91:LYS:CE	2:L:120:HIS:NE2	2.62	0.62
2:L:136:LYS:C	2:L:138:SER:N	2.56	0.62
2:L:230:SER:HB2	2:L:233:ASN:ND2	2.14	0.62
1:I:389:VAL:HG13	2:L:285:LEU:HD11	1.81	0.62
2:L:94:ALA:HA	2:L:351:LEU:HD23	1.82	0.62
2:L:111:ILE:O	2:L:113:GLU:N	2.32	0.62
2:L:241:LYS:HE2	2:L:247:CYS:SG	2.40	0.62
1:I:420:ILE:O	6:I:901:GOL:H32	2.00	0.61
2:L:414:GLU:OE1	2:L:416:PRO:HG2	2.01	0.61
2:L:346:PRO:HG3	2:L:363:TYR:CE2	2.36	0.61
2:L:263:VAL:CG2	2:L:267:THR:HB	2.31	0.61
2:L:15:ILE:CD1	2:L:16:PRO:HD2	2.31	0.60
2:L:358:GLY:O	2:L:359:ARG:HG3	2.01	0.60
2:L:204:SER:HA	7:L:845:HOH:O	2.02	0.60
2:L:212:VAL:HG21	2:L:362:LEU:HD22	1.84	0.60
1:I:355:VAL:HG13	1:I:362:LEU:CD2	2.30	0.59
1:I:331:LEU:HD21	1:I:369:HIS:HB2	1.85	0.59

Continued on next page...

Continued from previous page...

Atom-1	Atom-2	Interatomic distance (Å)	Clash overlap (Å)
1:I:355:VAL:CG1	1:I:362:LEU:HD22	2.31	0.59
1:I:202:ILE:HG22	1:I:206:ALA:HB3	1.84	0.59
2:L:285:LEU:N	2:L:285:LEU:HD23	2.18	0.59
1:I:143:ALA:HB3	1:I:218:THR:OG1	2.03	0.59
1:I:322:ARG:HG3	1:I:376:ASN:HA	1.85	0.59
1:I:199:THR:HG23	1:I:200:ASP:OD2	2.03	0.58
1:I:174:ASP:OD2	1:I:177:GLU:HB2	2.02	0.58
2:L:136:LYS:C	2:L:138:SER:H	2.10	0.58
2:L:158:TYR:HB2	2:L:353:GLY:O	2.03	0.58
2:L:230:SER:HB2	2:L:233:ASN:HD22	1.69	0.58
2:L:239:PHE:HE1	2:L:404:ALA:HB1	1.69	0.58
1:I:96:ASN:CG	3:A:1:NAG:HN2	2.11	0.58
1:I:213:LEU:HG	1:I:362:LEU:HD11	1.86	0.58
2:L:91:LYS:HE2	2:L:120:HIS:CE1	2.38	0.58
1:I:55:ASN:CB	6:I:901:GOL:H2	2.34	0.57
2:L:284:ILE:HD12	2:L:411:PHE:HE1	1.69	0.57
1:I:81:LEU:HD21	1:I:130:LEU:CD1	2.34	0.57
1:I:149:ASP:HA	1:I:173:LEU:O	2.04	0.57
2:L:208:ASN:C	2:L:208:ASN:HD22	2.09	0.57
1:I:81:LEU:HD13	6:I:901:GOL:H12	1.87	0.57
2:L:190:VAL:HG11	2:L:201:VAL:CG2	2.35	0.57
1:I:55:ASN:HB3	6:I:901:GOL:H2	1.87	0.56
1:I:190:VAL:HG21	1:I:201:VAL:HG11	1.87	0.56
1:I:240:TYR:O	1:I:407:PRO:HD3	2.06	0.56
1:I:115:THR:H	1:I:118:GLN:NE2	2.02	0.56
1:I:260:TYR:CG	1:I:261:ARG:N	2.74	0.56
1:I:390:ILE:HA	2:L:319:HIS:HB2	1.87	0.56
1:I:394:SER:HB3	2:L:240:TYR:H	1.71	0.56
1:I:91:LYS:HE3	1:I:120:HIS:CE1	2.41	0.56
2:L:365:SER:HB3	2:L:392:GLY:N	2.21	0.56
1:I:419:THR:CG2	6:I:901:GOL:H11	2.25	0.56
2:L:80:PRO:CG	2:L:423:MET:HE2	2.36	0.55
2:L:52:SER:HB2	2:L:419:THR:HG22	1.89	0.55
1:I:157:THR:O	1:I:161:ILE:HG13	2.07	0.55
1:I:381:GLU:O	1:I:382:ALA:CB	2.54	0.55
2:L:359:ARG:HB3	2:L:361:ASP:OD1	2.07	0.55
2:L:7:ILE:HG12	2:L:164:LEU:O	2.06	0.55
2:L:332:LYS:HG2	2:L:336:GLN:HE21	1.72	0.54
1:I:115:THR:CG2	1:I:117:ASP:H	2.13	0.54
1:I:16:PRO:CG	1:I:161:ILE:HD11	2.38	0.54
2:L:304:LEU:HD22	2:L:304:LEU:O	2.08	0.54

Continued on next page...

Continued from previous page...

Atom-1	Atom-2	Interatomic distance (Å)	Clash overlap (Å)
2:L:239:PHE:CE1	2:L:404:ALA:HB1	2.43	0.54
1:I:345:SER:O	1:I:349:SER:CB	2.56	0.53
2:L:331:LEU:O	2:L:335:LEU:HB2	2.08	0.53
2:L:428:ASN:OD1	2:L:430:CYS:HB2	2.08	0.53
2:L:365:SER:HB3	2:L:392:GLY:H	1.73	0.53
2:L:421:ILE:HG22	2:L:422:PHE:CD2	2.43	0.53
1:I:148:GLY:O	1:I:172:PRO:HA	2.08	0.53
1:I:332:LYS:HA	1:I:344:PHE:CZ	2.44	0.53
2:L:130:LEU:HD23	2:L:414:GLU:HG3	1.90	0.53
2:L:229:PHE:CE2	2:L:254:GLN:HG2	2.44	0.53
2:L:141:VAL:HG22	2:L:220:TYR:HB3	1.90	0.53
1:I:174:ASP:CG	1:I:177:GLU:HB2	2.33	0.53
3:A:1:NAG:H61	3:A:2:NAG:O5	2.09	0.53
2:L:51:LEU:CD2	2:L:123:PHE:HA	2.37	0.53
1:I:175:PHE:O	1:I:179:ALA:HB2	2.08	0.53
2:L:19:PRO:HD2	2:L:117:ASP:CB	2.38	0.53
2:L:198:ILE:CG2	2:L:201:VAL:HG22	2.39	0.53
4:B:2:NAG:H4	4:B:3:MAN:H3	1.91	0.53
2:L:300:THR:OG1	2:L:303:VAL:HG23	2.09	0.53
1:I:89:MET:HE3	1:I:166:TYR:HB2	1.91	0.52
4:B:2:NAG:H4	4:B:3:MAN:H5	1.91	0.52
1:I:13:ARG:HH11	1:I:13:ARG:HB3	1.75	0.52
1:I:281:MET:HE3	1:I:283:LEU:CD2	2.19	0.52
1:I:94:ALA:HB1	1:I:98:THR:HG22	1.91	0.52
1:I:163:GLU:O	1:I:167:GLY:HA2	2.09	0.52
1:I:273:PRO:HA	1:I:280:THR:HG22	1.92	0.52
1:I:96:ASN:OD1	3:A:1:NAG:N2	2.37	0.52
1:I:91:LYS:HB2	1:I:102:LEU:HD13	1.92	0.51
2:L:253:TYR:HA	2:L:318:VAL:O	2.10	0.51
2:L:284:ILE:HD13	2:L:307:TRP:CZ3	2.45	0.51
1:I:343:LEU:HD12	1:I:351:LEU:HD21	1.93	0.51
1:I:354:ILE:N	1:I:354:ILE:HD12	2.24	0.51
1:I:381:GLU:O	1:I:382:ALA:HB2	2.11	0.51
2:L:405:ASN:HD22	2:L:406:ARG:H	1.44	0.51
1:I:93:GLY:HA3	1:I:354:ILE:HD12	1.93	0.51
1:I:346:PRO:HD2	1:I:347:GLU:OE1	2.10	0.51
2:L:259:ARG:NH2	2:L:311:LEU:HB2	2.26	0.51
2:L:263:VAL:HG22	2:L:267:THR:HB	1.91	0.51
1:I:42:GLU:CB	1:I:44:THR:N	2.62	0.51
1:I:391:ALA:O	2:L:321:PRO:HD3	2.10	0.51
2:L:60:THR:O	2:L:64:GLN:HG3	2.11	0.51

Continued on next page...

Continued from previous page...

Atom-1	Atom-2	Interatomic distance (Å)	Clash overlap (Å)
2:L:284:ILE:C	2:L:285:LEU:HD23	2.36	0.50
2:L:355:VAL:HG23	2:L:362:LEU:HD11	1.93	0.50
3:C:1:NAG:O3	3:C:2:NAG:H2	2.11	0.50
2:L:91:LYS:NZ	2:L:120:HIS:NE2	2.59	0.50
2:L:292:LEU:CD2	2:L:407:PRO:HG2	2.28	0.50
1:I:202:ILE:HG21	1:I:207:ILE:HG13	1.94	0.50
1:I:290:LYS:HG2	1:I:291:SER:N	2.27	0.50
2:L:292:LEU:HD21	2:L:407:PRO:O	2.11	0.50
1:I:46:ARG:O	1:I:49:TRP:HB3	2.12	0.50
1:I:95:CYS:SG	1:I:96:ASN:OD1	2.70	0.49
2:L:396:ASN:O	2:L:398:ASN:N	2.46	0.49
2:L:215:LEU:HD12	2:L:215:LEU:H	1.77	0.49
1:I:153:THR:O	1:I:356:ALA:N	2.39	0.49
1:I:155:ASN:O	1:I:159:GLN:HG2	2.12	0.49
4:B:2:NAG:O3	4:B:3:MAN:H5	2.13	0.49
2:L:308:LEU:HD13	2:L:413:ARG:NH2	2.28	0.49
1:I:89:MET:HE2	1:I:162:SER:OG	2.13	0.49
1:I:121:PHE:O	1:I:124:ALA:HB3	2.12	0.49
1:I:313:GLU:O	1:I:314:MET:HE3	2.13	0.49
2:L:77:PHE:CE2	2:L:373:LEU:HB2	2.48	0.49
2:L:7:ILE:HD12	2:L:7:ILE:H	1.77	0.49
1:I:225:TRP:CD1	1:I:379:GLY:HA2	2.48	0.48
2:L:229:PHE:HB2	2:L:377:GLU:HA	1.94	0.48
1:I:199:THR:HG23	1:I:200:ASP:H	1.77	0.48
2:L:324:ARG:HA	2:L:373:LEU:O	2.13	0.48
1:I:289:GLU:H	1:I:289:GLU:CD	2.22	0.48
1:I:145:ARG:HH12	1:I:169:LYS:H	1.62	0.48
2:L:189:TRP:CE2	2:L:193:LYS:HE3	2.48	0.48
2:L:190:VAL:HG13	2:L:218:THR:CG2	2.44	0.48
2:L:260:TYR:CG	2:L:261:ARG:N	2.81	0.48
2:L:71:ASN:HB3	2:L:74:ASP:CG	2.39	0.48
2:L:253:TYR:CD1	2:L:253:TYR:C	2.91	0.48
2:L:278:ASP:O	2:L:415:VAL:HG23	2.12	0.48
1:I:101:GLN:O	1:I:105:VAL:HG23	2.14	0.48
1:I:269:VAL:HG12	1:I:311:LEU:HD21	1.95	0.48
1:I:411:PHE:CE2	1:I:423:MET:HE3	2.48	0.48
1:I:4:PRO:O	1:I:5:VAL:HB	2.13	0.48
2:L:135:ASN:O	2:L:136:LYS:CB	2.62	0.48
2:L:323:PHE:CD1	2:L:323:PHE:N	2.82	0.48
1:I:215:LEU:O	1:I:367:ALA:HA	2.14	0.48
2:L:292:LEU:O	2:L:295:VAL:N	2.47	0.47

Continued on next page...

Continued from previous page...

Atom-1	Atom-2	Interatomic distance (Å)	Clash overlap (Å)
1:I:108:PHE:HB3	1:I:119:ILE:CD1	2.44	0.47
1:I:302:GLU:CD	1:I:302:GLU:N	2.66	0.47
2:L:343:LEU:HG	2:L:364:VAL:CG2	2.44	0.47
2:L:405:ASN:CG	2:L:406:ARG:H	2.22	0.47
2:L:182:SER:O	2:L:185:ALA:HB3	2.14	0.47
2:L:220:TYR:CE2	2:L:222:LYS:HB2	2.49	0.47
1:I:91:LYS:NZ	1:I:120:HIS:NE2	2.48	0.47
1:I:115:THR:HB	1:I:118:GLN:HE21	1.80	0.47
1:I:202:ILE:CD1	1:I:207:ILE:HD11	2.44	0.47
2:L:57:ARG:HA	2:L:301:PRO:HG2	1.95	0.47
2:L:144:ASN:O	2:L:168:ALA:HA	2.14	0.47
1:I:115:THR:N	1:I:118:GLN:HE21	2.09	0.47
1:I:153:THR:HB	1:I:356:ALA:HB3	1.96	0.47
2:L:189:TRP:CZ2	2:L:193:LYS:HE3	2.50	0.47
2:L:229:PHE:CD2	2:L:254:GLN:HG2	2.49	0.47
2:L:396:ASN:O	2:L:397:PRO:C	2.56	0.47
2:L:78:LEU:HA	2:L:371:ALA:HB2	1.97	0.47
1:I:19:PRO:C	1:I:21:CYS:N	2.71	0.46
1:I:414:GLU:C	1:I:414:GLU:OE1	2.58	0.46
1:I:209:GLU:CD	1:I:209:GLU:H	2.22	0.46
1:I:66:LEU:HD21	1:I:329:PHE:CZ	2.51	0.46
2:L:7:ILE:HD12	2:L:7:ILE:N	2.30	0.46
2:L:190:VAL:HG21	2:L:201:VAL:HG21	1.96	0.46
1:I:258:PHE:CD1	1:I:272:LEU:HD23	2.51	0.46
1:I:42:GLU:CB	1:I:44:THR:HB	2.45	0.46
1:I:201:VAL:HG11	1:I:216:VAL:HG21	1.98	0.46
1:I:259:ARG:NH2	1:I:311:LEU:HB2	2.31	0.46
1:I:292:LEU:HD11	1:I:409:LEU:HG	1.98	0.46
1:I:324:ARG:HD2	1:I:374:GLU:OE2	2.16	0.46
2:L:44:THR:C	2:L:46:ARG:H	2.24	0.46
2:L:208:ASN:C	2:L:208:ASN:ND2	2.74	0.46
1:I:146:LEU:HB3	1:I:170:LEU:HD13	1.96	0.46
1:I:146:LEU:O	1:I:170:LEU:HD12	2.16	0.46
1:I:180:GLU:OE2	1:I:183:ARG:HD3	2.16	0.46
1:I:328:GLY:HA2	1:I:370:LYS:HD3	1.98	0.46
2:L:136:LYS:O	2:L:138:SER:N	2.49	0.46
1:I:178:ASN:HB3	1:I:181:GLN:CB	2.35	0.45
2:L:130:LEU:HG	2:L:417:LEU:HD13	1.97	0.45
1:I:49:TRP:NE1	1:I:53:LYS:HE2	2.31	0.45
1:I:115:THR:HB	1:I:118:GLN:HG3	1.98	0.45
1:I:144:ASN:OD1	1:I:217:ASN:HA	2.17	0.45

Continued on next page...

Continued from previous page...

Atom-1	Atom-2	Interatomic distance (Å)	Clash overlap (Å)
1:I:173:LEU:HD13	1:I:182:SER:HB3	1.98	0.45
1:I:263:VAL:HG22	1:I:267:THR:O	2.15	0.45
2:L:71:ASN:O	2:L:73:ASN:N	2.49	0.45
2:L:108:PHE:HB3	2:L:119:ILE:HG12	1.99	0.45
2:L:147:PHE:CD2	2:L:173:LEU:HD11	2.51	0.45
2:L:346:PRO:HB2	2:L:347:GLU:OE2	2.17	0.45
1:I:331:LEU:O	1:I:332:LYS:C	2.60	0.45
2:L:190:VAL:HG13	2:L:218:THR:HG22	1.98	0.45
2:L:292:LEU:O	2:L:293:ALA:C	2.60	0.45
1:I:255:GLU:OE1	1:I:395:LEU:HD13	2.17	0.45
2:L:147:PHE:HD2	2:L:173:LEU:HD11	1.82	0.45
2:L:215:LEU:HD12	2:L:215:LEU:N	2.32	0.45
1:I:398:ASN:O	1:I:399:ARG:C	2.60	0.45
1:I:172:PRO:O	1:I:173:LEU:HD23	2.17	0.45
1:I:269:VAL:CG1	1:I:311:LEU:HD21	2.47	0.45
1:I:201:VAL:HG11	1:I:216:VAL:CG2	2.47	0.45
2:L:217:ASN:CG	2:L:218:THR:N	2.74	0.44
2:L:74:ASP:O	2:L:425:ARG:HD2	2.18	0.44
2:L:77:PHE:CZ	2:L:373:LEU:HB2	2.52	0.44
3:A:1:NAG:H61	3:A:2:NAG:C1	2.47	0.44
2:L:62:PHE:HA	2:L:338:MET:HE1	1.99	0.44
1:I:91:LYS:CB	1:I:102:LEU:HD13	2.48	0.44
1:I:306:GLU:O	1:I:310:GLU:HG3	2.17	0.44
2:L:412:ILE:HB	2:L:422:PHE:HB2	2.00	0.44
2:L:221:PHE:CG	2:L:222:LYS:N	2.86	0.44
2:L:225:TRP:HB2	2:L:228:LYS:HA	1.99	0.44
4:B:1:NAG:O7	4:B:1:NAG:H3	2.17	0.44
1:I:281:MET:HA	1:I:411:PHE:O	2.18	0.44
1:I:80:PRO:O	1:I:84:SER:HB2	2.18	0.44
2:L:253:TYR:O	2:L:254:GLN:HB3	2.18	0.43
1:I:284:ILE:HB	1:I:409:LEU:HB2	2.01	0.43
2:L:198:ILE:HG22	2:L:201:VAL:HG22	2.00	0.43
2:L:274:PHE:CE1	2:L:380:SER:HB3	2.54	0.43
1:I:47:ARG:HB3	1:I:122:PHE:CD1	2.54	0.43
1:I:82:SER:O	1:I:83:ILE:C	2.60	0.43
1:I:277:ASP:OD2	1:I:277:ASP:N	2.50	0.43
2:L:179:ALA:O	2:L:182:SER:HB2	2.19	0.43
2:L:342:ASP:C	2:L:344:PHE:N	2.77	0.43
1:I:413:ARG:HB2	1:I:419:THR:O	2.19	0.43
1:I:420:ILE:HB	6:I:901:GOL:H31	1.99	0.43
2:L:405:ASN:O	2:L:406:ARG:C	2.60	0.43

Continued on next page...

Continued from previous page...

Atom-1	Atom-2	Interatomic distance (Å)	Clash overlap (Å)
2:L:71:ASN:C	2:L:73:ASN:N	2.76	0.43
1:I:96:ASN:CG	3:A:1:NAG:N2	2.77	0.43
2:L:198:ILE:HG21	2:L:201:VAL:HG22	2.00	0.43
2:L:320:MET:HE3	2:L:320:MET:HB2	1.94	0.43
1:I:401:CYS:SG	1:I:402:PHE:N	2.92	0.43
2:L:132:ARG:O	2:L:133:LYS:CG	2.63	0.43
2:L:174:ASP:OD2	2:L:177:GLU:CB	2.67	0.43
2:L:281:MET:HA	2:L:411:PHE:O	2.19	0.43
1:I:346:PRO:HG3	1:I:363:TYR:CZ	2.54	0.42
2:L:155:ASN:ND2	3:C:1:NAG:C7	2.83	0.42
1:I:25:SER:HB3	1:I:109:ASP:HB2	2.01	0.42
1:I:4:PRO:HB2	1:I:5:VAL:H	1.67	0.42
1:I:81:LEU:HD21	1:I:130:LEU:HD13	2.01	0.42
1:I:241:LYS:HE3	1:I:241:LYS:HB2	1.89	0.42
1:I:329:PHE:O	1:I:368:PHE:HA	2.19	0.42
2:L:47:ARG:O	2:L:51:LEU:N	2.52	0.42
2:L:73:ASN:HB3	2:L:404:ALA:O	2.19	0.42
2:L:418:ASN:O	2:L:418:ASN:CG	2.62	0.42
1:I:77:PHE:O	1:I:327:ASP:HB2	2.20	0.42
1:I:108:PHE:HB3	1:I:119:ILE:HD12	2.00	0.42
1:I:335:LEU:HA	1:I:335:LEU:HD23	1.75	0.42
2:L:334:GLN:OE1	2:L:334:GLN:N	2.33	0.42
1:I:285:LEU:HD21	1:I:403:LYS:O	2.20	0.42
2:L:65:HIS:CD2	2:L:338:MET:HE2	2.55	0.42
2:L:214:VAL:HG12	2:L:216:VAL:HG23	2.01	0.42
1:I:377:GLU:OE1	1:I:377:GLU:N	2.48	0.42
1:I:144:ASN:OD1	1:I:217:ASN:CA	2.68	0.41
2:L:372:PHE:O	2:L:382:ALA:HA	2.20	0.41
1:I:102:LEU:HD23	1:I:340:LEU:HD11	2.01	0.41
2:L:7:ILE:H	2:L:7:ILE:CD1	2.26	0.41
2:L:91:LYS:HZ1	2:L:120:HIS:CD2	2.38	0.41
2:L:178:ASN:ND2	2:L:181:GLN:CB	2.83	0.41
1:I:52:SER:HA	6:I:901:GOL:O1	2.20	0.41
1:I:56:SER:O	1:I:60:THR:HG23	2.21	0.41
1:I:130:LEU:HD22	1:I:140:LEU:CD2	2.50	0.41
2:L:278:ASP:OD1	2:L:278:ASP:N	2.53	0.41
1:I:115:THR:C	1:I:117:ASP:N	2.78	0.41
1:I:199:THR:HG23	1:I:200:ASP:N	2.35	0.41
2:L:284:ILE:HD12	2:L:411:PHE:CE1	2.52	0.41
1:I:199:THR:OG1	1:I:200:ASP:N	2.51	0.41
2:L:213:LEU:HG	2:L:214:VAL:N	2.35	0.41

Continued on next page...

Continued from previous page...

Atom-1	Atom-2	Interatomic distance (Å)	Clash overlap (Å)
2:L:282:VAL:HG21	2:L:413:ARG:HD3	2.02	0.41
1:I:77:PHE:CZ	1:I:422:PHE:HB3	2.56	0.41
2:L:100:GLN:O	2:L:104:GLU:HG3	2.21	0.41
2:L:136:LYS:CB	2:L:138:SER:HB2	2.51	0.41
2:L:345:SER:C	2:L:347:GLU:N	2.79	0.41
1:I:414:GLU:OE1	1:I:416:PRO:HD2	2.21	0.41
2:L:118:GLN:O	2:L:119:ILE:C	2.64	0.41
1:I:46:ARG:HA	1:I:49:TRP:HB3	2.03	0.41
1:I:81:LEU:HD21	1:I:130:LEU:HD11	2.02	0.41
1:I:315:MET:HE3	2:L:237:GLU:HG3	2.02	0.41
1:I:336:GLN:HA	1:I:340:LEU:O	2.21	0.41
2:L:44:THR:C	2:L:46:ARG:N	2.78	0.41
2:L:147:PHE:HA	2:L:171:GLN:O	2.21	0.41
2:L:175:PHE:O	2:L:209:GLU:HA	2.21	0.41
2:L:372:PHE:CD1	2:L:372:PHE:C	2.99	0.41
1:I:89:MET:O	1:I:92:LEU:HB2	2.21	0.41
2:L:59:ALA:HB1	2:L:423:MET:HE1	2.03	0.41
2:L:263:VAL:HG11	2:L:307:TRP:CD1	2.56	0.41
2:L:332:LYS:HG3	2:L:344:PHE:CD1	2.56	0.41
1:I:167:GLY:O	1:I:168:ALA:HB2	2.21	0.40
2:L:54:ALA:HB1	2:L:107:LYS:O	2.20	0.40
1:I:42:GLU:CB	1:I:44:THR:CB	3.00	0.40
1:I:63:TYR:OH	1:I:296:GLU:OE2	2.38	0.40
1:I:332:LYS:O	1:I:336:GLN:HG2	2.22	0.40
1:I:78:LEU:HB3	1:I:329:PHE:CE2	2.56	0.40
2:L:91:LYS:HE2	2:L:91:LYS:HB3	1.83	0.40
2:L:328:GLY:O	2:L:329:PHE:HB3	2.22	0.40
1:I:399:ARG:HH11	1:I:399:ARG:HG2	1.87	0.40
2:L:259:ARG:HB3	2:L:311:LEU:HB3	2.04	0.40
2:L:332:LYS:HG3	2:L:344:PHE:CE1	2.56	0.40

There are no symmetry-related clashes.

5.3 Torsion angles [\(i\)](#)

5.3.1 Protein backbone [\(i\)](#)

In the following table, the Percentiles column shows the percent Ramachandran outliers of the chain as a percentile score with respect to all X-ray entries followed by that with respect to entries of similar resolution.

The Analysed column shows the number of residues for which the backbone conformation was analysed, and the total number of residues.

Mol	Chain	Analysed	Favoured	Allowed	Outliers	Percentiles	
1	I	407/432 (94%)	350 (86%)	42 (10%)	15 (4%)	2	6
2	L	395/432 (91%)	343 (87%)	39 (10%)	13 (3%)	3	7
All	All	802/864 (93%)	693 (86%)	81 (10%)	28 (4%)	3	6

All (28) Ramachandran outliers are listed below:

Mol	Chain	Res	Type
1	I	199	THR
1	I	382	ALA
2	L	112	SER
2	L	397	PRO
1	I	5	VAL
1	I	43	ALA
1	I	113	GLU
1	I	383	ALA
1	I	399	ARG
2	L	72	ASP
2	L	136	LYS
1	I	19	PRO
2	L	45	ASN
2	L	228	LYS
1	I	26	PRO
1	I	289	GLU
1	I	332	LYS
1	I	385	SER
2	L	10	ALA
2	L	119	ILE
2	L	293	ALA
2	L	343	LEU
2	L	404	ALA
1	I	133	LYS
2	L	12	PRO
1	I	139	LYS
1	I	263	VAL
2	L	263	VAL

5.3.2 Protein sidechains [i](#)

In the following table, the Percentiles column shows the percent sidechain outliers of the chain as a percentile score with respect to all X-ray entries followed by that with respect to entries of similar resolution.

The Analysed column shows the number of residues for which the sidechain conformation was analysed, and the total number of residues.

Mol	Chain	Analysed	Rotameric	Outliers	Percentiles	
1	I	336/382 (88%)	319 (95%)	17 (5%)	21	48
2	L	310/383 (81%)	288 (93%)	22 (7%)	13	33
All	All	646/765 (84%)	607 (94%)	39 (6%)	17	41

All (39) residues with a non-rotameric sidechain are listed below:

Mol	Chain	Res	Type
1	I	41	PRO
1	I	84	SER
1	I	92	LEU
1	I	97	ASP
1	I	115	THR
1	I	128	CYS
1	I	153	THR
1	I	214	VAL
1	I	277	ASP
1	I	302	GLU
1	I	314	MET
1	I	315	MET
1	I	317	CYS
1	I	320	MET
1	I	331	LEU
1	I	380	SER
1	I	394	SER
2	L	7	ILE
2	L	21	CYS
2	L	47	ARG
2	L	95	CYS
2	L	97	ASP
2	L	138	SER
2	L	160	ASP
2	L	192	ASN
2	L	199	THR
2	L	208	ASN

Continued on next page...

Continued from previous page...

Mol	Chain	Res	Type
2	L	222	LYS
2	L	253	TYR
2	L	285	LEU
2	L	292	LEU
2	L	302	GLU
2	L	304	LEU
2	L	315	MET
2	L	324	ARG
2	L	341	VAL
2	L	397	PRO
2	L	415	VAL
2	L	423	MET

Sometimes sidechains can be flipped to improve hydrogen bonding and reduce clashes. All (20) such sidechains are listed below:

Mol	Chain	Res	Type
1	I	100	GLN
1	I	118	GLN
1	I	171	GLN
1	I	233	ASN
1	I	254	GLN
1	I	305	GLN
1	I	319	HIS
1	I	418	ASN
1	I	428	ASN
2	L	55	ASN
2	L	65	HIS
2	L	73	ASN
2	L	159	GLN
2	L	178	ASN
2	L	208	ASN
2	L	233	ASN
2	L	305	GLN
2	L	319	HIS
2	L	336	GLN
2	L	405	ASN

5.3.3 RNA [i](#)

There are no RNA molecules in this entry.

5.4 Non-standard residues in protein, DNA, RNA chains [i](#)

There are no non-standard protein/DNA/RNA residues in this entry.

5.5 Carbohydrates [i](#)

7 monosaccharides are modelled in this entry.

In the following table, the Counts columns list the number of bonds (or angles) for which Mogul statistics could be retrieved, the number of bonds (or angles) that are observed in the model and the number of bonds (or angles) that are defined in the Chemical Component Dictionary. The Link column lists molecule types, if any, to which the group is linked. The Z score for a bond length (or angle) is the number of standard deviations the observed value is removed from the expected value. A bond length (or angle) with $|Z| > 2$ is considered an outlier worth inspection. RMSZ is the root-mean-square of all Z scores of the bond lengths (or angles).

Mol	Type	Chain	Res	Link	Bond lengths			Bond angles		
					Counts	RMSZ	# Z > 2	Counts	RMSZ	# Z > 2
3	NAG	A	1	1,3	14,14,15	0.70	0	17,19,21	0.64	0
3	NAG	A	2	3	14,14,15	0.58	0	17,19,21	0.63	0
4	NAG	B	1	1,4	14,14,15	0.63	0	17,19,21	0.97	1 (5%)
4	NAG	B	2	4	14,14,15	0.69	0	17,19,21	0.82	0
4	MAN	B	3	4	11,11,12	0.61	0	15,15,17	0.91	1 (6%)
3	NAG	C	1	2,3	14,14,15	0.64	0	17,19,21	1.01	1 (5%)
3	NAG	C	2	3	14,14,15	0.55	0	17,19,21	0.67	1 (5%)

In the following table, the Chirals column lists the number of chiral outliers, the number of chiral centers analysed, the number of these observed in the model and the number defined in the Chemical Component Dictionary. Similar counts are reported in the Torsion and Rings columns. '-' means no outliers of that kind were identified.

Mol	Type	Chain	Res	Link	Chirals	Torsions	Rings
3	NAG	A	1	1,3	1/1/5/7	4/6/23/26	0/1/1/1
3	NAG	A	2	3	-	3/6/23/26	0/1/1/1
4	NAG	B	1	1,4	-	6/6/23/26	0/1/1/1
4	NAG	B	2	4	-	4/6/23/26	0/1/1/1
4	MAN	B	3	4	-	2/2/19/22	0/1/1/1
3	NAG	C	1	2,3	-	6/6/23/26	0/1/1/1
3	NAG	C	2	3	-	6/6/23/26	0/1/1/1

There are no bond length outliers.

All (4) bond angle outliers are listed below:

Mol	Chain	Res	Type	Atoms	Z	Observed(°)	Ideal(°)
3	C	1	NAG	C4-C3-C2	2.91	115.29	111.02
4	B	1	NAG	C2-N2-C7	-2.44	119.63	122.90
4	B	3	MAN	C1-C2-C3	2.28	112.97	109.64
3	C	2	NAG	C2-N2-C7	-2.02	120.19	122.90

All (1) chirality outliers are listed below:

Mol	Chain	Res	Type	Atom
3	A	1	NAG	C1

All (31) torsion outliers are listed below:

Mol	Chain	Res	Type	Atoms
3	A	1	NAG	C8-C7-N2-C2
3	A	1	NAG	O7-C7-N2-C2
3	A	2	NAG	C3-C2-N2-C7
3	A	2	NAG	C8-C7-N2-C2
3	A	2	NAG	O7-C7-N2-C2
3	C	1	NAG	C8-C7-N2-C2
3	C	1	NAG	O7-C7-N2-C2
3	C	2	NAG	C8-C7-N2-C2
3	C	2	NAG	O7-C7-N2-C2
4	B	1	NAG	C8-C7-N2-C2
4	B	1	NAG	O7-C7-N2-C2
4	B	2	NAG	C8-C7-N2-C2
4	B	2	NAG	O7-C7-N2-C2
4	B	3	MAN	C4-C5-C6-O6
3	A	1	NAG	O5-C5-C6-O6
3	C	2	NAG	O5-C5-C6-O6
3	A	1	NAG	C4-C5-C6-O6
4	B	3	MAN	O5-C5-C6-O6
4	B	2	NAG	O5-C5-C6-O6
3	C	2	NAG	C4-C5-C6-O6
4	B	2	NAG	C4-C5-C6-O6
3	C	1	NAG	O5-C5-C6-O6
4	B	1	NAG	C4-C5-C6-O6
4	B	1	NAG	O5-C5-C6-O6
3	C	1	NAG	C3-C2-N2-C7
3	C	2	NAG	C3-C2-N2-C7
3	C	1	NAG	C1-C2-N2-C7
4	B	1	NAG	C1-C2-N2-C7
4	B	1	NAG	C3-C2-N2-C7
3	C	2	NAG	C1-C2-N2-C7

Continued on next page...

Continued from previous page...

Mol	Chain	Res	Type	Atoms
3	C	1	NAG	C4-C5-C6-O6

There are no ring outliers.

7 monomers are involved in 16 short contacts:

Mol	Chain	Res	Type	Clashes	Symm-Clashes
3	C	2	NAG	1	0
3	C	1	NAG	4	0
4	B	3	MAN	3	0
4	B	1	NAG	3	0
3	A	2	NAG	2	0
3	A	1	NAG	6	0
4	B	2	NAG	5	0

The following is a two-dimensional graphical depiction of Mogul quality analysis of bond lengths, bond angles, torsion angles, and ring geometry for oligosaccharide.

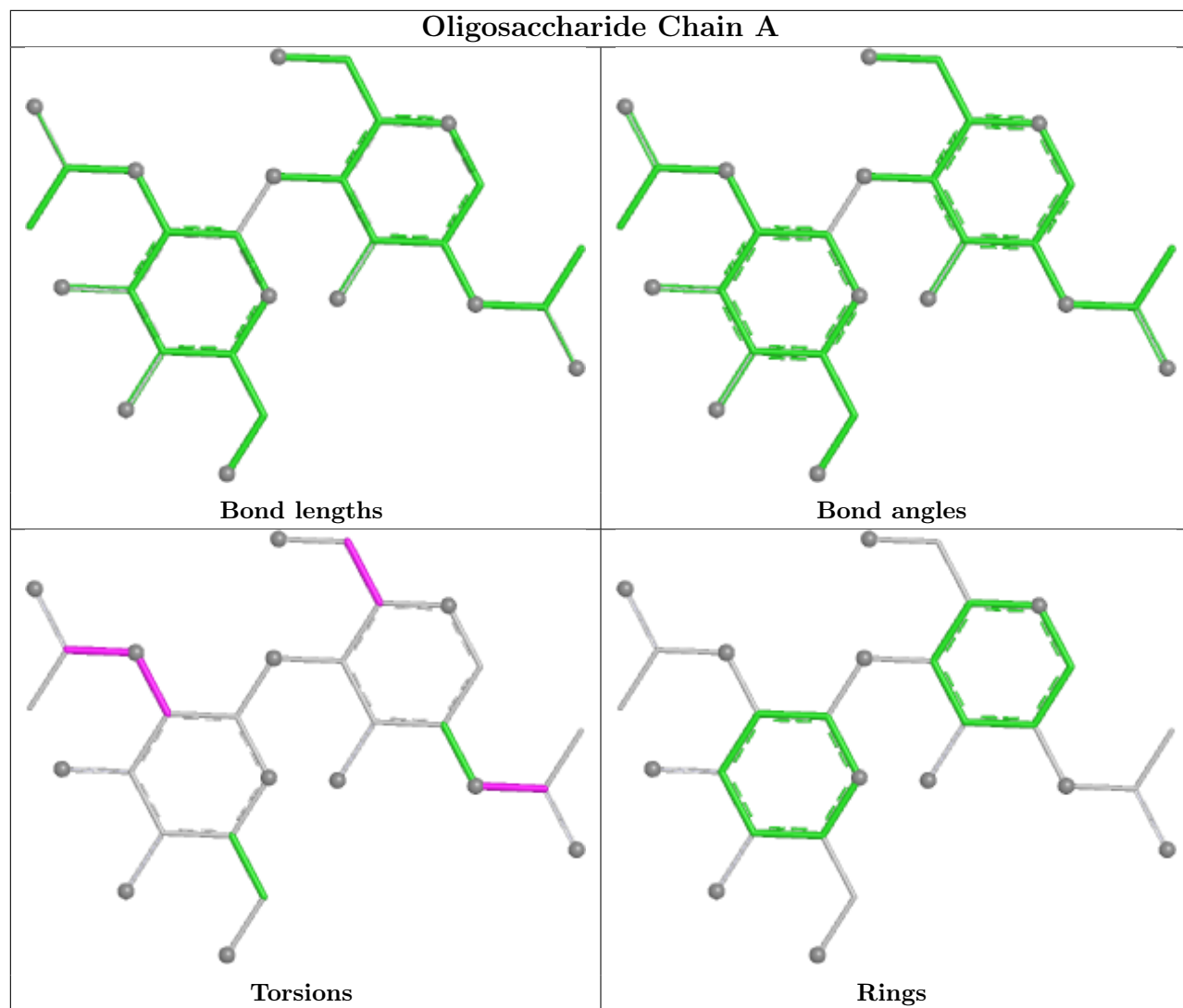

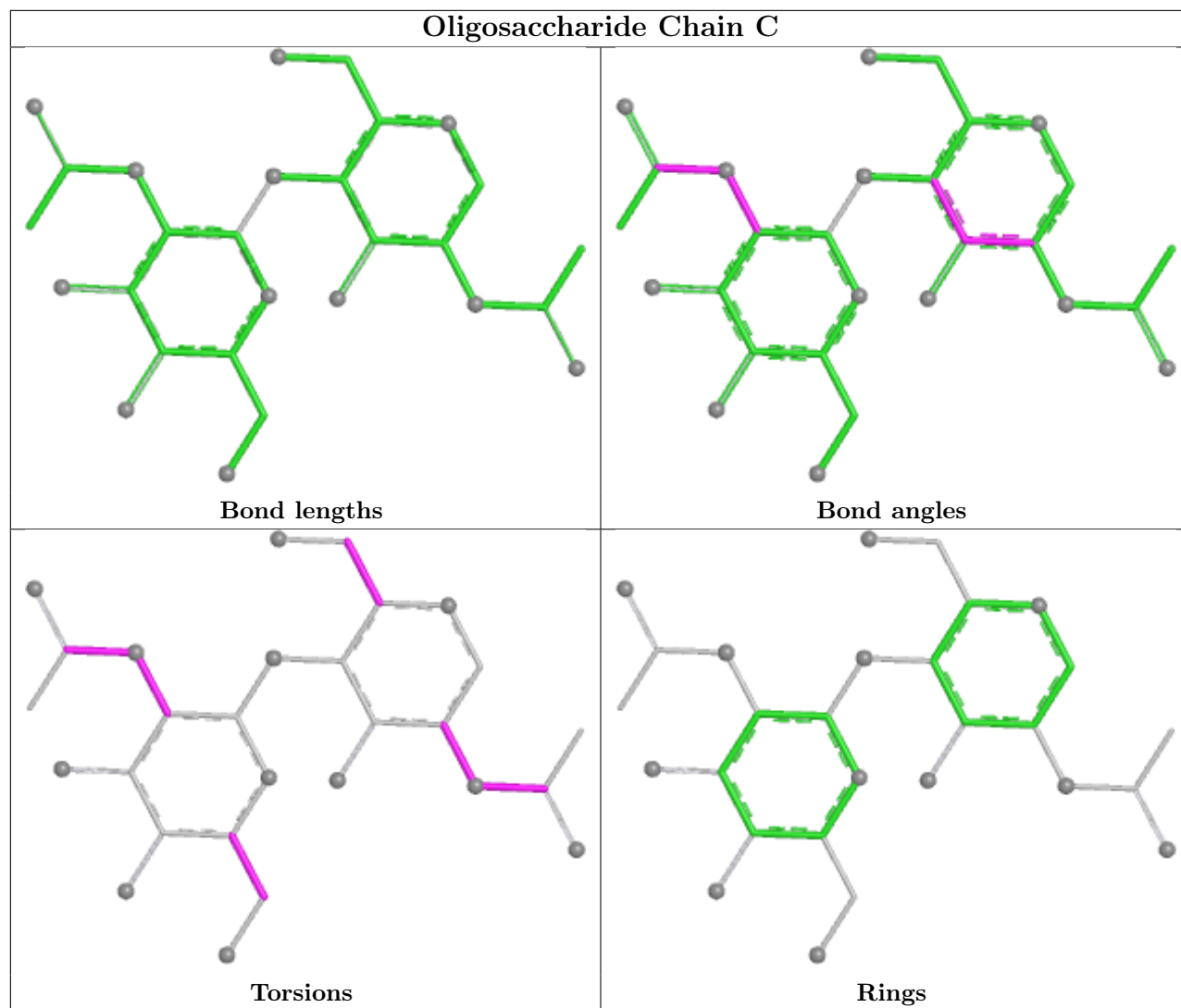

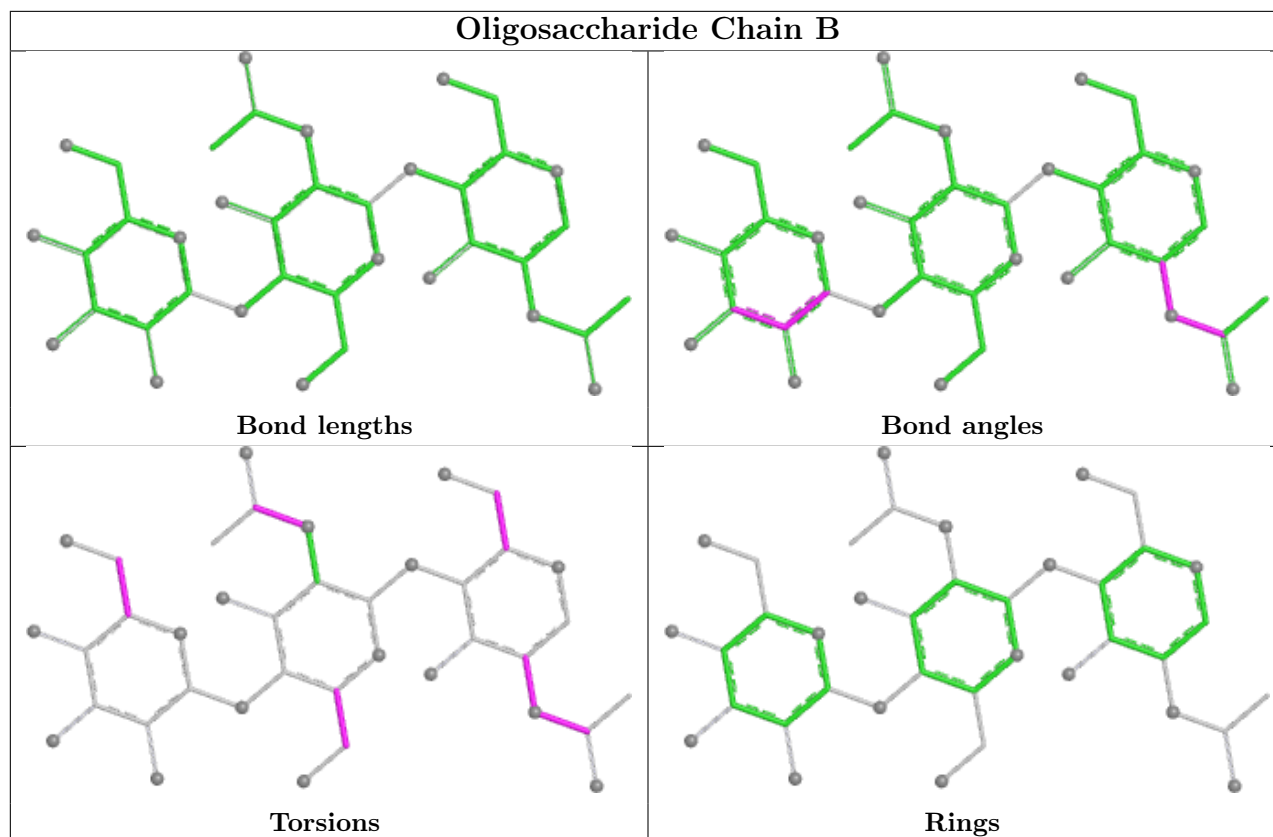

5.6 Ligand geometry [i](#)

3 ligands are modelled in this entry.

In the following table, the Counts columns list the number of bonds (or angles) for which Mogul statistics could be retrieved, the number of bonds (or angles) that are observed in the model and the number of bonds (or angles) that are defined in the Chemical Component Dictionary. The Link column lists molecule types, if any, to which the group is linked. The Z score for a bond length (or angle) is the number of standard deviations the observed value is removed from the expected value. A bond length (or angle) with $|Z| > 2$ is considered an outlier worth inspection. RMSZ is the root-mean-square of all Z scores of the bond lengths (or angles).

Mol	Type	Chain	Res	Link	Bond lengths			Bond angles		
					Counts	RMSZ	$\# Z > 2$	Counts	RMSZ	$\# Z > 2$
5	NAG	I	861	1	14,14,15	0.56	0	17,19,21	0.74	1 (5%)
6	GOL	I	901	-	5,5,5	1.00	0	5,5,5	0.52	0
5	NAG	L	801	2	14,14,15	0.58	0	17,19,21	0.57	0

In the following table, the Chirals column lists the number of chiral outliers, the number of chiral centers analysed, the number of these observed in the model and the number defined in the Chemical Component Dictionary. Similar counts are reported in the Torsion and Rings columns. '-' means no outliers of that kind were identified.

Mol	Type	Chain	Res	Link	Chirals	Torsions	Rings
5	NAG	I	861	1	-	2/6/23/26	0/1/1/1
6	GOL	I	901	-	-	2/4/4/4	-
5	NAG	L	801	2	-	5/6/23/26	0/1/1/1

There are no bond length outliers.

All (1) bond angle outliers are listed below:

Mol	Chain	Res	Type	Atoms	Z	Observed(°)	Ideal(°)
5	I	861	NAG	C2-N2-C7	-2.23	119.91	122.90

There are no chirality outliers.

All (9) torsion outliers are listed below:

Mol	Chain	Res	Type	Atoms
5	I	861	NAG	C8-C7-N2-C2
5	I	861	NAG	O7-C7-N2-C2
5	L	801	NAG	C1-C2-N2-C7
5	L	801	NAG	O7-C7-N2-C2
5	L	801	NAG	C8-C7-N2-C2
5	L	801	NAG	O5-C5-C6-O6
6	I	901	GOL	O2-C2-C3-O3
6	I	901	GOL	C1-C2-C3-O3
5	L	801	NAG	C4-C5-C6-O6

There are no ring outliers.

1 monomer is involved in 8 short contacts:

Mol	Chain	Res	Type	Clashes	Symm-Clashes
6	I	901	GOL	8	0

5.7 Other polymers [i](#)

There are no such residues in this entry.

5.8 Polymer linkage issues [i](#)

There are no chain breaks in this entry.

6 Fit of model and data

6.1 Protein, DNA and RNA chains

In the following table, the column labelled ‘#RSRZ > 2’ contains the number (and percentage) of RSRZ outliers, followed by percent RSRZ outliers for the chain as percentile scores relative to all X-ray entries and entries of similar resolution. The OWAB column contains the minimum, median, 95th percentile and maximum values of the occupancy-weighted average B-factor per residue. The column labelled ‘Q < 0.9’ lists the number of (and percentage) of residues with an average occupancy less than 0.9.

Mol	Chain	Analysed	<RSRZ>	#RSRZ>2	OWAB(Å ²)	Q<0.9
1	I	413/432 (95%)	0.32	13 (3%) 51 48	32, 59, 85, 105	0
2	L	403/432 (93%)	0.42	20 (4%) 34 30	34, 61, 101, 123	0
All	All	816/864 (94%)	0.37	33 (4%) 42 38	32, 60, 94, 123	0

All (33) RSRZ outliers are listed below:

Mol	Chain	Res	Type	RSRZ
1	I	41	PRO	4.0
1	I	43	ALA	3.6
2	L	135	ASN	3.4
2	L	43	ALA	3.3
2	L	398	ASN	3.1
1	I	4	PRO	3.0
2	L	113	GLU	3.0
2	L	396	ASN	3.0
2	L	5	VAL	3.0
2	L	240	TYR	3.0
1	I	17	MET	2.9
1	I	401	CYS	2.9
2	L	24	ARG	2.8
1	I	366	ASP	2.6
2	L	7	ILE	2.5
2	L	19	PRO	2.4
2	L	44	THR	2.4
1	I	22	ILE	2.4
2	L	405	ASN	2.4
2	L	358	GLY	2.4
2	L	115	THR	2.3
1	I	18	ASN	2.3
2	L	49	TRP	2.3
2	L	395	LEU	2.3

Continued on next page...

Continued from previous page...

Mol	Chain	Res	Type	RSRZ
1	I	142	SER	2.2
2	L	134	ALA	2.1
1	I	355	VAL	2.1
2	L	16	PRO	2.1
1	I	395	LEU	2.1
2	L	17	MET	2.0
1	I	431	VAL	2.0
2	L	430	CYS	2.0
1	I	5	VAL	2.0

6.2 Non-standard residues in protein, DNA, RNA chains [i](#)

There are no non-standard protein/DNA/RNA residues in this entry.

6.3 Carbohydrates [i](#)

In the following table, the Atoms column lists the number of modelled atoms in the group and the number defined in the chemical component dictionary. The B-factors column lists the minimum, median, 95th percentile and maximum values of B factors of atoms in the group. The column labelled 'Q< 0.9' lists the number of atoms with occupancy less than 0.9.

Mol	Type	Chain	Res	Atoms	RSCC	RSR	B-factors(Å ²)	Q<0.9
3	NAG	A	1	14/15	-	-	103,105,109,112	0
3	NAG	A	2	14/15	-	-	112,116,117,117	0
3	NAG	C	2	14/15	0.61	0.15	107,110,112,112	0
3	NAG	C	1	14/15	0.67	0.14	89,93,99,103	0
4	NAG	B	1	14/15	-	-	91,97,99,106	0
4	NAG	B	2	14/15	-	-	111,114,117,121	0
4	MAN	B	3	11/12	-	-	124,126,127,127	0

The following is a graphical depiction of the model fit to experimental electron density for oligosaccharide. Each fit is shown from different orientation to approximate a three-dimensional view.

Electron density around Chain A:

$2mF_o-DF_c$ (at 0.7 rnsd) in gray
 mF_o-DF_c (at 3 rnsd) in purple (negative)
and green (positive)

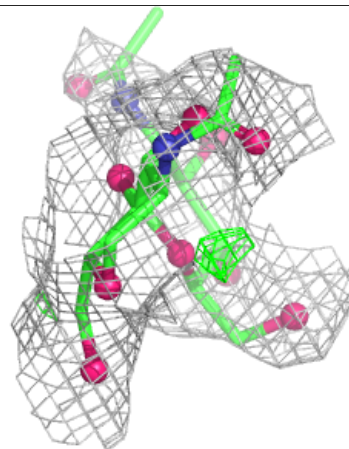
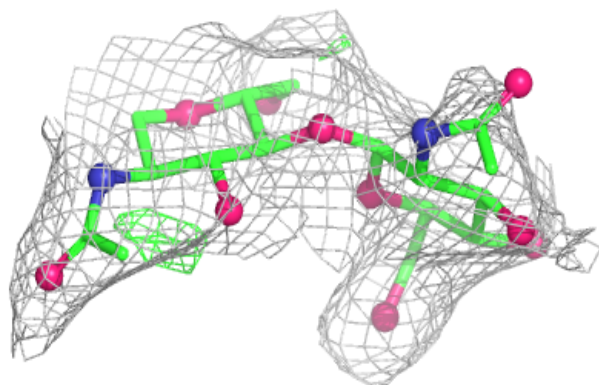
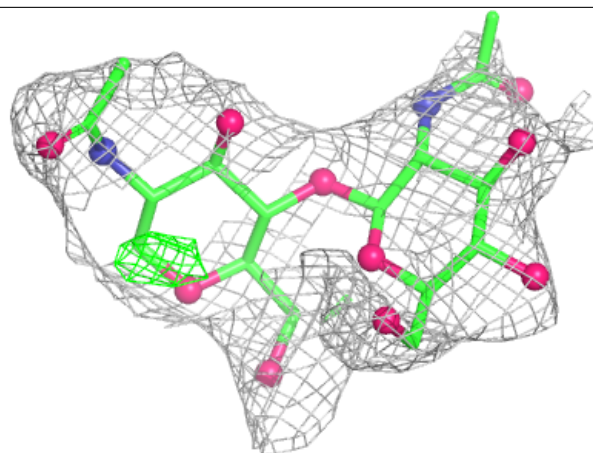

Electron density around Chain C:

$2mF_o-DF_c$ (at 0.7 rmsd) in gray
 mF_o-DF_c (at 3 rmsd) in purple (negative)
and green (positive)

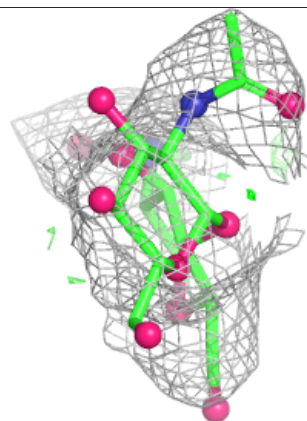
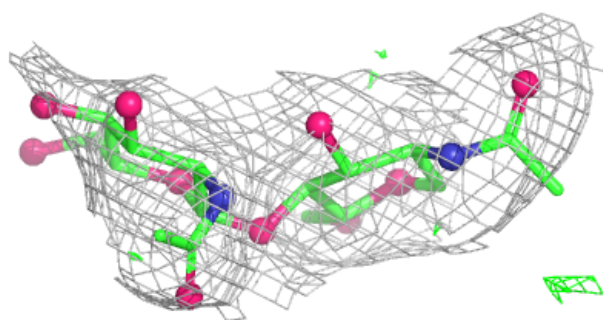
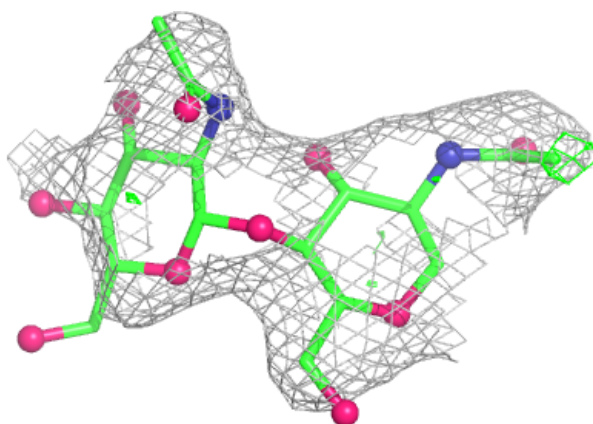
**Electron density around Chain B:**

$2mF_o-DF_c$ (at 0.7 rmsd) in gray
 mF_o-DF_c (at 3 rmsd) in purple (negative)
and green (positive)

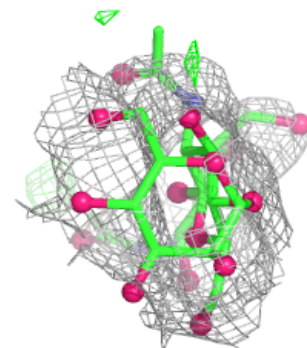
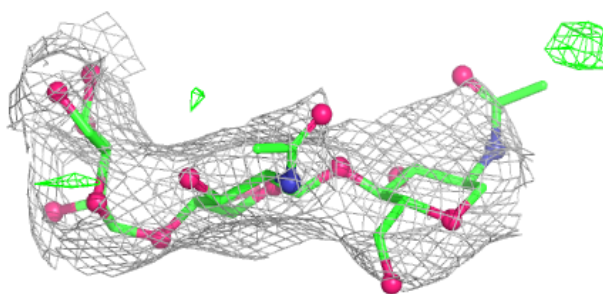
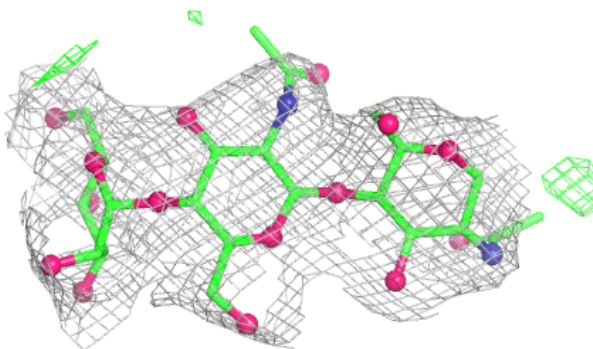

6.4 Ligands [i](#)

In the following table, the Atoms column lists the number of modelled atoms in the group and the number defined in the chemical component dictionary. The B-factors column lists the minimum, median, 95th percentile and maximum values of B factors of atoms in the group. The column labelled 'Q< 0.9' lists the number of atoms with occupancy less than 0.9.

Mol	Type	Chain	Res	Atoms	RSCC	RSR	B-factors(Å ²)	Q<0.9
5	NAG	L	801	14/15	0.43	0.17	97,99,101,102	0
5	NAG	I	861	14/15	0.55	0.14	96,98,100,101	0
6	GOL	I	901	6/6	0.82	0.25	52,57,57,61	0

6.5 Other polymers [i](#)

There are no such residues in this entry.